

# Mine Detection Dogs

## Training, Operations and Odour Detection



# Mine Detection Dogs: Training, Operations and Odour Detection



---

The **Geneva International Centre for Humanitarian Demining** (GICHD) supports the efforts of the international community in reducing the impact of mines and unexploded ordnance. The Centre is active in research, provides operational assistance and supports the implementation of the Anti-Personnel Mine Ban Convention.

---

***For further information please contact:***

**Geneva International Centre for Humanitarian Demining**  
7bis, avenue de la Paix  
P.O. Box 1300  
CH-1211 Geneva 1  
Switzerland  
Tel. (41 22) 906 16 60  
Fax (41 22) 906 16 90  
[www.gichd.ch](http://www.gichd.ch)  
[info@gichd.ch](mailto:info@gichd.ch)

*Mine Detection Dogs: Training, Operations and Odour Detection*, GICHD, Geneva, 2003.

This report was edited for the GICHD by Ian G. McLean, Mine Dog Specialist ([i.mclean@gichd.ch](mailto:i.mclean@gichd.ch)).

ISBN 2-88487-007-5

---

© Geneva International Centre for Humanitarian Demining

The views expressed in this publication are those of the listed author(s) for each part, and do not necessarily represent the views of the Geneva International Centre for Humanitarian Demining. The designations employed and the presentation of the material in this publication do not imply the expression of any opinion whatsoever on the part of the Geneva International Centre for Humanitarian Demining concerning the legal status of any country, territory or area, or of its authorities or armed groups, or concerning the delimitation of its frontiers or boundaries.

---

# Contents

|  |    |
|--|----|
| <b>Foreword</b>  | 1  |
| <b>Introduction</b>  | 3  |
| <b>Chapter 1. Perspectives on animal learning theory</b>   | 7  |
| <b>Part 1. Comparing training concepts and styles</b>  | 7  |
| <i>Ian G. McLean</i>   |    |
| References   | 10 |
| <b>Part 2. General learning principles for training REST dogs</b>                                | 11 |
| <i>Rune Fjellanger</i>   |    |
| Creating a desired behavioural pattern   | 11 |
| Shaping  | 12 |
| • Shaping with the clicker ...   | 13 |
| Multiple-choice training   | 15 |
| Stimulus discrimination  | 15 |
| • Scent discrimination and threshold for detection: an example of<br>discrimination training ... | 16 |
| Reinforcement  | 17 |
| • Positive and negative reinforcers ...  | 18 |
| • Distribution of reinforcement<br>— intermittent reinforcement ...                              | 18 |
| References   | 21 |
| <b>Part 3. Principles of animal learning</b>   | 23 |
| <i>Stewart Hilliard</i>  |    |
| Summary  | 23 |
| Introduction   | 25 |
| Animal learning  | 26 |
| • Habituation ...  | 26 |
| • Classical conditioning ...   | 28 |
| • Instrumental<br>conditioning ...   | 30 |
| Primary and secondary reinforcement and punishment   | 32 |

|   |           |
|---|-----------|
| Systems of instrumental training  | 33        |
| • Inducive training ... 33 • Compulsive training ... 33 • Application of inducive training ... 34 • Successive approximation and shaping ... 35   |           |
| Reward schedules  | 35        |
| • Application of reward schedules ... 37 • Advantages of variable reward schedules ... 37   |           |
| Application of compulsive training  | 38        |
| • Use of physical punishment ... 38 • Use of negative reinforcement ... 39  |           |
| Generalisation of classical and instrumental conditioning   | 41        |
| Generalisation of behaviour learned in one context to another context   | 41        |
| Transfer of learning  | 42        |
| <b>Chapter 2. Case studies on training mine detection dogs</b>  | <b>43</b> |
| <b>Part 1. Socialising puppies for demining</b>   | <b>43</b> |
| <i>Johan van Wyk and André Le Roux</i>  |           |
| Introduction  | 43        |
| Choice of parents   | 44        |
| Care of the dam   | 45        |
| The new arrivals  | 45        |
| The socialisation process for the first 16 weeks  | 45        |
| • Neonatal period (0-2 weeks) ... 45 • Transition period (third week) ... 46  |           |
| • Socialisation (3-6 weeks) ... 47 • Socialisation (6-8 weeks) ... 48   |           |
| • Socialisation (8-12 weeks) ... 49 • Socialisation (12-13 weeks) ... 49  |           |
| • Socialisation (13-14 weeks) ... 50 • Socialisation (14-16 weeks) ... 50   |           |
| Programme for 4-8 months  | 51        |
| Programme for 8-12 months   | 51        |
| <b>Part 2. The REST concept</b>   | <b>53</b> |
| <i>Rune Fjellanger</i>  |           |
| Introduction  | 53        |
| • The REST case studies: collecting information ... 54 • The REST system in operation ... 55 • Sampling ... 55 • Breaching ... 56   |           |
| • Analysis of new filter cartridges ... 58 • Handling the filter cartridges and filter containers prior to and during the analysis process ... 60   |           |
| Training methodology for vapour analysing dogs: three case studies  | 61        |
| Case study 1: Mechem  | 61        |
| • Collecting information ... 62 • General ... 62 • Selection of dogs ... 62 • The training programme: explosive odour imprinting ... 63 • The training programme: improving discrimination ... 65 • Assessment of dogs during training ... 66 |           |
| • Maintenance training ... 66 • Use of REST in the execution of survey contracts: scent trapping and analysis ... 67  |           |
| Case study 2: Norwegian People's Aid  | 69        |
| • The REST project in Angola ... 69 • Collecting information ... 70   |           |
| • Dog selection ... 70 • Training ... 71 • Explosive odour imprinting ... 72 • Assessment of dogs during training ... 74  |           |
| • Maintenance training ... 74 • The analysis process ... 76   |           |

|   |     |
|---|-----|
| Case study 3: Norsk Kompetansesenter for Spesialsøkshund AS (NOKSH AS)  | 77  |
| • Organisation of the work ... 77 • Selection of dogs ... 77  |     |
| • Training ... 79 • Explosive odour imprinting ... 81 • Monitoring progress: methods and results for assessment of dogs during training ... 86 • The training programme for REST dogs at NOKSH ... 87 • Maintenance training and operational use ... 91 |     |
| • Procedures for testing unknown filters ... 91   |     |
| Analysis and discussion   | 92  |
| • Sampling ... 93 • Filter cartridges ... 93 • Training of REST dogs ... 95 • Assessment during training ... 97 • Maintenance ... 98  |     |
| • The operational analysis of filters ... 98 • Further development of REST ... 99   |     |
| References  | 101 |
| <i>Annexes:</i>   |     |
| 1. Equipment requirements in training of REST detection dogs  | 102 |
| 2. Examples of sampling, analysis and assessment forms used in REST dog training  | 105 |
| <b>Part 3. Training dogs to detect tripwires</b>  | 109 |
| <i>Dan Hayter</i>   |     |
| Tripwire protocol   | 109 |
| • Lessons learned ... 109 • Introduction of tripwires ... 109   |     |
| <i>Annexes</i>  |     |
| 1. Protocol for tripwire testing  | 118 |
| 2. Interim study report and summary of results, 10 July 2001  | 120 |
| 3. Interim study report and summary of results, 27 February 2001  | 125 |
| 4. Interim study report, 20 January 2001  | 127 |
| 5. Chemical analysis of tripwires   | 129 |
| <b>Chapter 3. Training, organisation and skills: case studies of practice using mine detection dogs</b>   | 139 |
| <i>Per Jostein Matre</i>  |     |
| Introduction  | 139 |
| Objectives  | 139 |
| Methods   | 139 |
| Results   | 141 |
| • Identification of test criteria for the selection of mine detection dogs ... 141 • Guidelines for the training and handling of mine detection dogs ... 142 • General guidelines for educational programmes for trainers and handlers ... 142          |     |
| Discussion  | 142 |
| • Training methods ... 142 • Information flow within organisations ... 143  |     |
| Principles of practice  | 146 |
| • Trainer and handler abilities ... 146   |     |
| Summary and conclusions   | 147 |
| References  | 148 |

*Annexes:*

|  |     |
|--|-----|
| 1. System and practice at organisation N1                            | 149 |
| 2. System, collation of knowledge, and management of organisation N2 | 152 |
| 3. Process and collation of knowledge at organisation N3             | 154 |
| 4. Organisational requirement at N4                                  | 158 |
| 5. Skills and knowledge needed when working with dogs                | 160 |

**Chapter 4. Programme reviews****Part 1. The Mechem Explosive and Drug Detection System (MEDDS)** 165*Vernon Joynt*

Background 165

The MEDDS landmine clearance system 166

Research and development on MEDDS 167

MEDDS 168

- Chemical tests ... 168
- Other Mechem tests ... 169
- Detection distance ... 169

Operational results for MEDDS 170

- Trusting only negative results ... 170
- Use statistics to achieve the 99.6 per cent UN standard of clearance ... 170
- Enhanced MEDDS ... 171
- Area reduction ... 171
- Comparison with manual demining ... 172

**Part 2. Preliminary results on the use of *Cricetomys* rats as indicators of buried explosives in field conditions** 175*Ron Verhagen, Christophe Cox, Robert Machangu, Bart Weetjens, and Mic Billet*

Summary 175

Introduction 176

Why rats? 177

- How rats came into the picture ... 177

Which rat? 177

- *Cricetomys gambianus* ... 178
- Field application of the rat technology ... 180
- Material and methods ... 180

Results 183

- Overall performance ... 184

Conclusions 192

References 193

**Chapter 5. Odour detection: the theory and the practice****Part 1. How do dogs detect landmines? A summary of research results** 195*Ann Göth, Ian G. McLean and James Trevelyan*

Summary 195

Introduction 196

Aim 197

|  |     |
|--|-----|
| Canine olfactory capabilities and characteristics  | 197 |
| What substances from landmines are available to the dogs?  | 200 |
| • Chemical characteristics of substances found in mines ...  | 200 |
| • Presence of mine substances in soil and vapour ...   | 202 |
| Discussion and conclusions   | 204 |
| References   | 207 |
| <b>Part 2. Chemical sensing for buried landmines: fundamental processes influencing trace chemical detection</b> | 209 |
| <i>James M. Phelan and Stephen W. Webb</i>   |     |
| Abstract   | 209 |
| 1. Introduction  | 211 |
| 2. Numbers in chemistry  | 211 |
| • Key information ...  | 212 |
| • Scientific notation ...  | 212 |
| • Concentrations ...   | 212 |
| • Molecular structure and formulas ...   | 214 |
| 3. Target chemical compounds   | 215 |
| • Key information ...  | 215 |
| • TNT manufacturing impurities ...   | 215 |
| • Vapour signature above bulk TNT ...  | 215 |
| • Summary ...  | 217 |
| 4. Landmine chemical emissions   | 217 |
| • Key information ...  | 218 |
| • Leakage and permeation ...   | 218 |
| • External surface contamination ...   | 221 |
| • Polymer coupon permeability ...  | 222 |
| • TNT solubility in plastics ...   | 223 |
| • Landmine flux tests ...  | 224 |
| • Summary ...  | 227 |
| 5. Chemical distribution in soils  | 227 |
| • Key information ...  | 227 |
| • Background ...   | 227 |
| • Air and water solubility ...   | 228 |
| • Air-water partitioning ...   | 228 |
| • Soil-water partitioning ...  | 229 |
| • Soil-air partitioning ...  | 231 |
| • Integrated soil chemical partitioning ...  | 232 |
| • Summary ...  | 235 |
| 6. Chemical degradation in soils   | 235 |
| • Key information ...  | 236 |
| • Background ...   | 236 |
| • Analyte stability studies ...  | 237 |
| • Natural attenuation studies ...  | 238 |
| • Post-blast residue degradation ...   | 238 |
| • Summary ...  | 240 |
| 7. Chemical transport in soils   | 240 |
| • Key information ...  | 241 |
| • Diffusion ...  | 241 |
| • Convection ...   | 243 |
| • Vapour transport through soils ...   | 243 |
| • Summary ...  | 244 |
| 8. Weather factors affecting chemical sensing  | 245 |
| • Key information ...  | 246 |
| • Weather factors ...  | 246 |
| • Atmospheric pressure ...   | 247 |
| • Soil surface temperature ...   | 247 |
| • Soil water content ...   | 249 |
| • Air boundary layer ...   | 249 |
| • Effect of dogs ...   | 250 |
| • Plants ...   | 250 |
| • Summary ...  | 251 |
| 9. Landmine-soil-weather systems analysis  | 251 |
| • Key information ...  | 252 |
| • Complex interdependencies ...  | 252 |
| • Simulation modeling tools ...  | 253 |
| • Model validation ...   | 257 |
| • Demonstration calculations ...   | 259 |
| • Summary ...  | 260 |
| 10. Soil residues from landmines   | 260 |
| • Key information ...  | 263 |
| • Soil sampling and analytical methods ...   | 263 |
| • Soil residues ...  | 264 |
| • Vapour concentration estimates ...   | 266 |
| • Summary ...  | 266 |
| 11. Vapour-sensing thresholds of dogs  | 267 |
| • Key information ...  | 267 |
| • Vapour-sensing threshold screening tests ...   | 267 |
| • Sensing by soil particle inhalation ...  | 270 |



|   |            |
|---|------------|
| <ul style="list-style-type: none"> <li>• Comparison with vapour estimates from field landmine soil residues ... 270</li> <li>• Summary ... 271</li> </ul>   |            |
| 12. Summary   | 271        |
| Bibliography  | 275        |
| List of figures   | 284        |
| List of tables  | 285        |
| <b>Afterword: Animal detection in the future</b>  | <b>287</b> |
| <i>Håvard Bach</i>  |            |
| Dogs versus alternative vapour technology   | 288        |
| Alternative sensor technology   | 289        |
| Future role of the GICHD MDD project  | 289        |
| <ul style="list-style-type: none"> <li>• Disseminating information ... 289</li> <li>• Environmental factors ... 290</li> <li>• Breeds ... 290</li> <li>• Rats - a realistic alternative ... 290</li> <li>• Improving operational procedures ... 292</li> <li>• Remote Explosive Scent Training ... 292</li> <li>• International standards and guidelines ... 295</li> </ul> |            |
| The way ahead: issues to debate   | 295        |
| <b>Glossary of terms</b>  | <b>299</b> |
| <b>Notes on contributors</b>  | <b>301</b> |

---

## Acknowledgements

This document summarises the results of research from the first two years of the Mine Detection Dog (MDD) Research Programme, which was initiated by the GICHD in 2000. It was prepared by the GICHD on behalf of the mine dog detection industry, who have contributed to its development in many ways. Some contributions were sourced from outside the GICHD research programme because they are of central interest to the use of dogs for mine detection. The GICHD gratefully thanks all the authors who contributed for their time and efforts.

Production of this document for the GICHD was managed by Ian G. McLean. Editing was by Ian G. McLean and Jack Glattbach. Layout was by Françoise Jaffré.

The ongoing efforts, support and contribution of the MDD Advisory Group are acknowledged with thanks. The following donors provided project funding: the Governments of Germany, Japan, Norway, Sweden, the United Kingdom and the United States.

---

# Foreword

**T**he detection of mines is the most critical element of an effective and cost-efficient mine-clearance operation. During the last decade, enormous investment has been made in many areas of research, but the silver bullet has not yet been found. In the view of the Geneva International Centre for Humanitarian Demining (GICHD), mine detection dogs (MDDs) offer one of the most promising avenues for making demining operations faster and less expensive.

The use of dogs for mine detection has expanded dramatically in the last ten years. However, research designed to explore and understand the issues underlying mine dog detection has not kept pace with that expansion. A poor knowledge base was recognised as a key limitation on further development and exploitation of this fascinating detection technology. The GICHD therefore accepted the challenge of initiating a programme of research on mine detection dogs, with the specific objectives of (1) improving understanding of the skills and limitations of dogs, (2) optimising their deployment and performance, and (3) raising confidence in their work.

This book is the first extensive overview of that programme of research, which has produced considerable success but also encountered some difficulties. Several projects are still underway and are not reported on in detail here. Some areas of research are still raising more questions than providing answers, and there is much more to be done. The book is therefore as much a report on work in progress as on completed projects. It provides valuable reviews of current knowledge in key areas, an up-to-date summary of topical issues, some historical perspectives and some empirical results. I invite you to explore the book with an eye on what remains to be achieved, as well as on the details within the chapters.

The research described here could not have been achieved without the support of a large number of cooperating partners, individuals and institutions. The writers of each chapter or section in the book have contributed a great deal of time and effort to producing the best possible product, and have individually acknowledged their support where appropriate. Perhaps even more important has been the extraordinary array of industry and other supporters, too numerous to name, who have assisted the

GICHD and its contractors in our endeavours to better understand the secrets of mine detection dogs. Without that support this book would have been impossible, and the GICHD gratefully acknowledges their contribution. The MDD programme is funded by the European Union, and the Governments of Germany, Japan (through the United Nations Trust Fund), Norway, Sweden, the United Kingdom, and the United States.

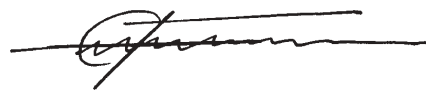

Ambassador Martin Dahinden  
Director  
Geneva International Centre  
for Humanitarian Demining

# Introduction

**T**his book is mostly about mine detection dogs, although it includes a first report on mine detection rats. Many of the issues discussed, particularly in Chapters 1 and 5, are about detection or training issues, and are not specific to dogs. The book has been written in part to fill a gap in the available information on the use of dogs in mine action, and in part to present the results of research that has taken place at the GICHD and its partner organisations since the start of the GICHD Mine Dog Detection Study in September 1999. This introduction provides some background to both the study and this book.

Using dogs to detect mines and other explosive devices is a technique that has been in both military and civil use for many years, but only began to come into prominence with the introduction of humanitarian mine action following the end of the Cold War. The earliest mine action programmes were inefficient and unsafe, partly because the clearance organisations were learning their trade, and partly because they had very few tools with which to work. Increasing numbers of mine action programmes began to use dogs, but with very mixed results. Some organisations swore by them; others swore at them. In some, there were claims of excellent performance, whereas with others, even in the same theatre of operations, dogs were deemed a failure. While there was good knowledge of how to breed and give basic training to dogs for explosive detection, there was less knowledge of how to achieve the right interaction between dog handler and dog, or of the optimum method of search. Variation in results compromised confidence, and lower confidence in the dog teams produced distrustful programme managers. Once the managers lost confidence in what was, after all, an expensive component of their clearance operation, the dog detection element spiralled downwards in utility.

This, then, was the situation in 1999 when the GICHD started its operations. Fortunately, there was an important mine conference in Ljubljana in September of that year, including a seminar on the use of mine detection dogs. The conference was attended by Håvard Bach, who had recently joined the GICHD. He was deeply interested in the use of dogs for mine detection, having employed them in Mozambique and Angola while managing Norwegian People's Aid (NPA) programmes. Having returned from the Ljubljana meeting with a determination to assist the mine detection

dog community to set up a study into the production, training, accreditation and use of mine detection dogs, he convinced the Norwegian Government to provide start-up funds. Thus, the GICHD study was born.

At the same time, the rest of mine action development was not standing still. The so-called “honeymoon” period of public and donor interest in humanitarian demining that began in 1994 showed signs of cooling down, with donors becoming more critical and expecting safer and more cost-effective mine action programmes. Mine action techniques were themselves coming under scrutiny — by 1996, for example, questions were being asked about why the whole of a suspected mined area had to be put through a full clearance process. In low-density areas containing widely distributed mines and unexploded ordnance (UXO), such as were being cleared at the time in Cambodia, Mozambique, Rwanda, and Somalia, this question had not seemed relevant. However, in Bosnia in 1996 it became obvious that unless the 16,000 declared suspected areas could be reduced in numbers and area by what became “Level 2 Survey” or “area reduction”, the clearance costs would be impossible to meet. Dogs and mechanical equipment became two obvious candidates for use as area reduction tools, a fact later reflected in the GICHD studies into both these techniques. There were also calls for more stringent quality control measures, and dogs, again, were seen as possible candidates for this role.

Mechanical equipment, too, was undergoing a radical change. The first clumsy adaptations of military minefield breaching machines were being replaced by a new generation of smaller, more flexible and versatile, products designed to be used by local teams for humanitarian clearance in difficult terrain. It was still generally agreed that machines alone were unlikely to be able to clear mines to the United Nations (UN) desired clearance standards, so the machine became part of a “system”, or toolbox. Also in the box were manual clearance teams and dog detection teams. Again, the role of the detection dog was expanding in scope.

In May 1999, the UN tasked the GICHD to completely rewrite and overhaul the International Standards for Mine Action (IMAS). First drafted after the Copenhagen Conference in 1996, the early IMAS made little reference to dogs, and provided no guidance as to their use. It was evident that IMAS on the use of dogs would be needed, so this requirement was added to the aims of the study. It was against the tapestry of all these developments in mine action that the GICHD Mine Dog Detection Study began.

To provide staffing for the study, the Swedish Rescue Services Agency kindly seconded Conny Åkerblom to the GICHD. With his wide experience setting up dog training schools and evaluating dog programmes, he has added, and continues to add, greatly to the credibility of the GICHD dog programme. The team was also joined by Dr. Ian McLean from the University of Western Australia, who has added a rigorous research approach and a broad background in animal behaviour and psychology to the more operational thinking of most mine action practitioners. For a period, he was ably assisted by Ann Göth, another researcher in the field of animal behaviour, who contributed part of this book before taking a university research post in Australia.

The Mine Dog Detection Study, like all GICHD studies, was guided by a working group of invited practitioners and specialists. The first meeting of this working group revealed the existence of many different perspectives in the detection dog world — indeed the first meeting was likened to a dog-fight. The atmosphere of mutual

suspicion and distrust, and the unwillingness to accept any form of standards or regulations were symptomatic of the lack of cohesion within the mine dog community as a whole. It is noteworthy that a completely new atmosphere had been created by the time of the end of the second working group meeting, and since that time the levels of mutual trust and cooperation have been remarkable.

This book represents the results of some of the research undertaken as part of the Mine Dog Detection Study. It is by no means comprehensive, and it represents in some instances a “flashlight photo” of the situation as at the time of printing. The Mine Dog Study is a living organism, with new research areas being continuously developed and explored, and new ideas emerging from completed studies. Most developments are at the request of the mine dog community, made either through the Advisory Group or, more directly, as a result of the work of GICHD personnel in the field. Some of the results presented in the book have been circulated elsewhere as papers or unpublished reports, but nowhere have they been gathered together in this way.

## Structure of the book

Chapter 1 provides an introduction to the theory of animal psychology from a dog trainer’s perspective. Two different perspectives are given, with an introductory commentary that draws out the differences between them.

Chapter 2 provides three case studies on various issues underlying the training of mine detection dogs. Socialisation is a central issue if the dogs are to be used in environments containing members of the public (as is commonly the case in Cambodia, for example). An effective socialisation programme also ensures that the dog is accustomed to the complexity of the environments in which it will be working, so that it is not distracted by (e.g.) loud noises, animals, other dogs or difficult terrain. Filter search dogs are becoming increasingly important as detection tools, and the experimental training programme described here is the first published attempt to document such a programme. Training for detection of tripwires is a controversial and difficult problem, but this analysis shows that it is possible to achieve such detection consistently.

Chapter 3 provides a wide-ranging analysis of the cultures underlying operational mine dog detection programmes. The original requirements of this study proved to be too ambitious, and some of the issues in the original terms of reference now form part of other ongoing projects. However, this report is a valuable first step towards improving the understanding and quality of administration of operational programmes.

Chapter 4 provides hands-on analyses written by the people who did the ground work on two exciting recent developments in detection technology using animals. Originally called MEDDS, Remote Explosives Scent Tracing (REST) was first developed in South Africa and the early history of its development and use is described in Part 1. African Pouched rats are still under development for both field and REST search applications, and their potential for use in field search is described in Part 2. These two developments are certainly the most innovative advances in demining technology using animals in the last decade, although their utility requires further exploration.

Lastly, the two parts in Chapter 5 explore issues underlying environmental effects on the odour signals presented to dogs by buried mines. The first part is a shorter and less technical overview of many of the issues addressed in greater detail in the second part.

Much of the literature reviewed in this book, particularly in Chapter 5, is accessible to the reader on a CD-ROM obtainable on request from GICHD (the MDD bibliography). The bibliography provides a comprehensive review of the literature on dogs relevant to training, evolution, breeding and genetics, behaviour and odour detection. It is a valuable companion to this volume.

The principle concepts described in technical detail in the book are also described visually in a companion series of videos that should be completed soon after the book is published. As with the book and the MDD bibliography, the videos are available to the demining community at no cost on request from the GICHD.

In conclusion, this volume represents a written synopsis of the current state of knowledge for the GICHD dog programme. The authors' aims for this first book were to provide an interesting, informative and challenging overview of a series of poorly understood issues. The book provides some answers, but also raises many questions. Its target audience is all people involved with mine detection animals, including handlers, trainers, users, managers, sponsors, administrators and researchers. We encourage you to embrace the challenges that it raises, and to support ongoing exploration of issues that beg further investigation.

## Chapter 1

# Perspectives on animal learning theory

### Part 1

# Comparing training concepts and styles

*Ian G. McLean*

**I**n this chapter, two perspectives on the theoretical principles underlying training of mine detection dogs are offered. Both were originally used as background for particular training objectives (Fjellanger — training REST dogs; Hilliard — training to detect tripwires), but both have considerable generality in that they review the principles of the psychology of learning. There is therefore considerable overlap between them.

The overlap involves some repetition for the reader, and those with a background in the principles of learning may consider it unnecessary to have included both contributions. The principles are widely written about anyway (example references in Fjellanger, Chapter 1, Part 2; Matre, Chapter 3), and any dog trainer should have a reasonable understanding of them.

However, the main value of these two perspectives is in the thought-provoking differences between them. It is routinely commented that five dog trainers in a room will give six opinions about the best way to achieve a training objective — four opinions are strongly held, while the fifth trainer can see at least two options. Despite their differences, the five trainers will still agree on the principles of learning being applied because the disagreement among them centres on applications. It is therefore unsurprising that these two perspectives on dog training differ in significant ways.

The agreement can easily be found. Both contributions explain the concept of reinforcement, the need for precise timing links between action and reward, the meaning of *positive* and *negative* in relation to reinforcement and punishment, and the importance of intermittent use of rewards. Hilliard considers it appropriate to use limited forms of punishment (Fjellanger disagrees), although both agree that punishment must be used carefully. Fjellanger emphasises shaping as the most preferable training technique, whereas Hilliard discounts shaping almost entirely. Application of their arguments can be found in the parts written by Fjellanger and Hayter in Chapter 2.

One of the difficulties in reading texts on learning theory is the extensive use of a complex technical language which must be learned before the text is understandable.



Dog trainers, especially those for whom English is a second language, may not have the time (or for that matter, patience) to learn that language. Fjellanger minimises use of technical language in his part by keeping it in the background, although he provides the language where relevant. Hilliard uses the language more frequently, and his approach is similar to the writing in an undergraduate textbook in psychology.

Dog training involves the application of scientific principles of learning, but is also a constantly evolving art. It is now widely recognised that an important shift in training style took place during the 1990s, particularly among trainers who work with the general public. That shift has been captured in many books on dog training written for general use. Examples are Karen Pryor's *Don't Shoot the Dog* (1985) and Robert Mugford's *Never Say No!* (1992). Not all professional trainers have embraced the shift, although some also say "we already did that", and it is fair to say that, to some extent, they are right.

The shift began with attempts to train dolphins rather than dogs. Communication between animal and trainer is an essential (if poorly understood) component of the training process. Communication with dolphins is much more difficult than with dogs, because it is mediated through water. Dolphins also move much more quickly in water than humans. Thus, dolphin trainers were faced with the problem of supplying precisely timed rewards to reinforce desired actions for an animal that exhibited rapid changes in behaviour in a medium in which the trainer was at a physical disadvantage. The solution was communication through sound. Dolphins certainly responded to sound, but the problem was to make a sound rewarding. The solution was to use classical conditioning techniques to link a sound (a whistle) with something that was already rewarding for the dolphin (food) using the principle of *secondary conditioning*. Before long, the dolphins responded to the sound as though it was food; i.e. the sound had become rewarding. The trainer now had a powerful tool that gave precise timing for rewarding desired actions.

Animal psychologists rapidly recognised that the training concept was not restricted to dolphins. It crossed all animal boundaries and today has been used to train many kinds, including even those most untrainable of animals: cats. The principle has come to be called *clicker training* because of the frequent use of a clicking device as the primary sound producer. However, the clicker is simply a mechanism for establishing communication with the dog, and should not be confused with the training principle, which is reward-based learning (sometimes also called "shaping", although this concept is more specific). Reward-based learning is not new, which is why established trainers can argue that "we already do that". What made this training approach new?

For dogs, there were four significant elements of the shift in training style:

- The dog was given control of the training process;
- De-emphasised was the notion that the most effective training was achieved through a close relationship in which the handler *led* the dog;
- Forms of punishment or negative reinforcement were eliminated from the training experience; and
- Prompts, or leading the dog towards a desired behaviour (see below), were eliminated from the training process.

Hilliard offers a traditional view of the process of training a dog, whereas Fjellanger gives a modern view that emphasises the shift in training style outlined above. The

differences can be seen both in the recommended training approach, and in the contradictory statements in some areas.

Here are some examples of alternative perspectives, or contradictions. The reader is invited to find more.

- **Hilliard** refers to the notions of “needs and drives”, although he notes that this language is no longer used by behavioural scientists. **Fjellanger** does not mention these concepts.
- **Hilliard** notes that working dogs are selected for a moderate to high level of aggressiveness; and he makes various comments about dominance. **Fjellanger** makes no reference to dominance or aggression issues.
- **Fjellanger**: “**Prompt**” here, means *assisting the dog to express an action*. For example, pushing down on the rear end of the dog while training the action of sit. The optimal application of the forward training principle involves providing a minimum of prompt, even though the initial learning process may be slower than can be achieved with more prompt.<sup>1</sup> **Hilliard**: Assisting the dog to assume the desired position or behaviour is permissible (i.e. in the case of the sit, gentle pressure on the rump to encourage the animal to sit)... Inducing the animal to perform the desired behaviour independently and then reinforcing the behaviour will produce more rapid learning than “pushing” the animal into position and then rewarding it for allowing this to happen.
- **Fjellanger**: But as training goes on and the dog is *offering* the behaviour reliably without the reward being provided... **Hilliard**: When we train animals, what we do is exploit the animal’s desire to “feel good” by *requiring* the animal to do as we wish it to before we allow it to engage in one of these basic motivating behaviours...<sup>2</sup>
- **Fjellanger**: From Chapter 2, Part 2: It [the leash] must not be used for checking or jerking (a form of punishment). **Hilliard**: *Examples of punishers are jerks on the collar (collar corrections)*... when administered to a dog after it misbehaves by, for example, departing from the down-stay position without permission, will tend to weaken down-stay-breaking behaviour.<sup>3</sup>
- A notable similarity is that trainers in both styles are expected to use “small changes in behaviour” (Fjellanger, from Chapter 2, Part 2), or a JND (just noticeable difference) (Hayter, from Chapter 2, Part 2/3). These notions imply that trainers using either style require considerable experience observing the subtleties of dog behaviour.

It is important to emphasise that neither of these approaches is “right” in any fundamental sense. Hilliard’s description is of a training style that has been used successfully for decades, and is still the preferred style for the training of protection and security dogs. Fjellanger’s description incorporates an approach that is now commonly used by the general public, but which is almost completely untested with respect to the training of MDDs. As noted by Fjellanger in Chapter 2, Part 2, the differences of opinion in the examples above may produce no difference in the end-product (a dog capable of undertaking all required operational tasks). This is one reason why there are so many differences of opinion among dog trainers. All of them are right in the sense that their style will probably produce a trained dog.

---

1. Bold and italics as in the original.

2. Italics added.

3. Italics as in the original.

Relevant to preference for the difference in these two styles is the question of what characteristics are desirable in an MDD, and whether it is appropriate to produce an MDD using a training style originally developed for producing protection dogs. MDDs are not protection dogs, and many of the desirable characteristics for a protection dog are irrelevant for an MDD (although Hilliard and Hayter might disagree with this comment; see GICHD 2001 for an analysis of desirable characteristics for an MDD). Some trainers of detection dogs are beginning to indicate preferences for breeds other than the breeds traditionally used as MDDs (German shepherd and Malinois — which are also the preferred breeds for use as protection dogs). For example, the most successful detection dog breeding programme in the world (run by the Australian Customs Service) uses Labrador retrievers exclusively (Vandaloo, 2001). The development of breed preferences for different roles is driven by links between breed characteristics and characteristics desirable in the end product, and by preferences for training styles based on experience. It may well be that the approach described by Hilliard is the best training style for German shepherds and Malinois, even if they are to be used as MDDs. Other breeds might better be trained in other ways.

Differences in training styles are therefore not closely related to the quality of the end product. However, the following issues are relevant, and readers are encouraged to consider them while reading this book:

- The importance of the handler: Hilliard emphasises the need for a good dog-handler relationship; Fjellanger insists that the dog should work independently of the handler.
- The ability of the handler: Many MDDs work with handlers who have a limited understanding of dog behaviour, and an even more limited understanding of the principles of learning.
- The speed and efficiency with which training proceeds.
- The effectiveness of the training in establishing behavioural patterns that are resistant to changes arising from operational experiences (including training mistakes).
- The requirement for maintenance training once the dog is operational.

## References

- GICHD (2001)  
*Designer dogs: Improving the quality of mine detection dogs*, GICHD, Geneva.
- Mugford, R. (1992)  
*Dog training the Mugford way. Never say No!*, Hutchinson/Stanley Paul, London.
- Pryor, K. (1985)  
*Don't Shoot the Dog*, Bantam Books, Washington D.C.
- Vandaloo, J. (2001)  
*Breeding and developing detector dogs*, at [www.leads.org.uk/members/nbdcbreed.htm](http://www.leads.org.uk/members/nbdcbreed.htm)

## Chapter 1 Perspectives on animal learning theory

### Part 2

# General learning principles for training REST dogs

*Rune Fjellanger*

**T**he aim here is to provide an overview of the general principles of learning relevant to the training of a REST (Remote Explosive Scent Tracing) dog. A complete review of these principles can be found in many psychology texts or dog training guides (e.g. Catania, 1992; Pryor, 1996).

REST is a detection system in which the odour from suspect land is transferred to a dog at a testing station, via a filter. Air from the suspect land is vacuumed through the filter, and the role of the dog is to determine whether or not the filter contains the odour of a mine. At present, there are no standardised training or operational procedures designed to ensure either quality and level of skill for a REST dog, or for the execution of the analysis by the dogs. The results of a REST analysis may therefore vary in practice.

Results from practical tests using REST dogs indicate that the system gives consistent detection of mines, and the system has been used operationally for some years by Mechem in South Africa (see Chapter 4, Part 1) and, more recently, by Norwegian People's Aid (NPA) in Angola (see Chapter 2, Part 2).

## Creating a desired behavioural pattern

Most organised dog training is based on the idea that behaviour consists of a chain of functionally related smaller units or actions. Training has the goal of linking these simple actions together to produce a more complex behavioural pattern. The pattern will involve the expression of the set of simple actions in a desired sequence.

For example, here is a set of actions: A1, A2, A3, A4, where these actions can be anything that the dog is capable of doing (e.g. A1 = "sit", A4 = "stay"). The desired sequence is A2 A3 A1 A4. The trainer first teaches the dog to express each of the actions individually, using reinforcement. So the dog will be trained to "sit" (A1), to "stay" (A4), etc., and these training experiences will occur at different times. Reinforcement will be used to encourage the expression of each action, and to perfect the way in

which the action is expressed. The notion of *reinforcement* is described in detail below.

Now the dog is expressing each action well, and the trainer can begin linking the actions into a sequence. So A1 is linked to A4. In effect, in the mind of the dog, A1 and A4 become *one* behaviour, and it is the combination of actions that is now reinforced. Eventually, the trainer will link all four of the desired actions to create a complex behavioural pattern, which is reinforced as a unit. An example would be to train the dog to walk a line (A2), sniff at a series of filters (A3), sit (A1) and stay (A4).

In reality, this process uses the same procedure to develop the pattern as was used to train each of the desired actions separately.

The trainer has now done what is called in technical terms *forward chaining* — the creation of a behavioural sequence by linking previously established actions in the dog's repertoire.

The challenge when using forward chaining is to break the behavioural pattern into small pieces that can be handled with a small amount of prompt (assistance). If too much prompt is provided, the result can be a dependency of the dog on the assistance provided by the trainer, and a rapid loss of response when the assistance is removed. The optimal application of the principle involves providing a minimum of prompt, even though the initial learning process may be slower than can be achieved with more prompt.

*Prompt* here means *assisting the dog to express an action*. For example, pushing down on the rear end of the dog while training the action of sit. It is essential to understand that prompt can be something very small — something in the body language of the trainer for example — and the ability to recognise that a prompt is being given to the dog depends on the trainer, and their experience.

During the process of learning, a close relationship forms between the dog and the dog handler. A training programme consists of a repeated series of events in which the trainer encourages the expression of an action ("assistance"), the dog attempts to do the action, and reinforcement is provided. Training means teamwork.

Many of the stimuli which influence the learning process cannot be controlled by the dog handler/trainer, but are nonetheless present and are, in many instances, used by the dog (Gordon *et al.*, 1981). This implies that skills learned by a dog can be difficult to transfer into different situations and with different persons. When dogs are to be moved from the training situation to actual projects where they are to carry out tests/analysis (e.g. the REST system), the same difficulties will be encountered. We are therefore faced with considerable challenges in organisation and practical execution — when test results must be exclusively based on the dog's reactions, without any form of influence by the test procedures.

## Shaping

A method that can be used for training is referred to as *shaping* (successive approximations) (Catania, 1992; Bandura, 1986). Shaping is one of numerous forms of learning, but its value lies in being entirely reward-based, making it a very effective

technique for dog training. Shaping is based on reinforcement of an action or behaviour demonstrated by the dog. Reinforced behaviour is likely to be repeated with increasing frequency and reliability. Shaping entails starting out with minor tendencies in a dog's behavioural pattern and directing those tendencies towards an end target behaviour. All animals display varying behavioural patterns. In many instances, it is sufficient for the dog to move in a certain way or look in the right direction. With shaping, such tendencies are reinforced in order to increase the probability of repetition. Most dog trainers use some form of shaping in this way, often unknowingly. For example, when the dog is doing something right (something the trainer wishes the dog to do more often), the trainer uses his/her voice (praise) as a reinforcer.

The voice (praise) is the reinforcer, and the action being reinforced is the immediately previous action of the dog when the praising voice was heard. Praise could also be patting the dog, a food titbit, a ball or a game. All of these things provided by the trainer are reinforcers that the dog associates with positive feelings. The reliable appearance of the praise leads the dog to repeat its action with increased reliability; and that is the essence of shaping.

### *Shaping with the clicker*

It is similarly possible to shape behaviour using a whistle or "clicker". Such aids are used in the same way as the praising stimuli referred to above. The sounds are nothing more than a "uniform voice", i.e. a sound stimulus at a more controlled level of volume and frequency than is possible using voice or the other kinds of praise, and allowing more precise control of the timing of presentation.

If clickers are to be used, the dog must learn that the sound of the clicker predicts the appearance of a reward. The trainer therefore starts the learning process by presenting the sound of the "clicker" when the dog gets something rewarding, i.e. food, or some other form of reinforcement (a process of *secondary reinforcement*, as described by Hilliard in Part 3 of this chapter). Food is recommended as the most potent reinforcement to establish the rewarding nature of the clicker. It will require as many as 30-50 presentations of the clicker to establish it as a predictor of food. The trainer begins by sounding the clicker and giving food to the dog. The trainer is actively offering food to the dog in association with the clicker. Eventually the dog will begin to turn towards the trainer at the sound of the clicker in the expectation of the food appearing. Now, the trainer becomes more passive and so encourages the dog to move towards the trainer in order to receive the food, which the dog is beginning to associate with the sound of the clicker. Eventually, the trainer becomes completely passive and the dog will be focusing on the trainer in anticipation of both the sound of the clicker and the appearance of the food. Now, the problem for the dog is to get the trainer to give the clicker sound because it knows that the click predicts food.

At this point, the clicker sound has been established as rewarding and the dog will work for the sound of the clicker in the absence of any other reward. However, use of the clicker as the reward will involve ongoing maintenance of that conditioned association. Thus, there will be a need to continue to offer a reward in association with the clicker, but at a reduced frequency. In other words, the reward need not be offered every time the clicker is sounded. The reward used to maintain the clicker as rewarding can now be anything that the dog finds rewarding — the ball, praise, food, petting, etc.



From this moment on, almost any activity can be reduced or increased as desired. If the clicker is used when the dog is active and exploring, the dog will tend to exhibit increased amounts of exploration. If the dog is calm, sitting, lying or focusing on a search, the clicker can be used to increase this behaviour.

Shaping is most simple in practice using the dog's current behaviour. Because the clicker is used simultaneously or immediately after an action has been offered, the dog will repeat the action more often. In some instances, actions are offered regularly, and so are easy to shape because there is plenty of potential for reinforcement. In other cases, the trainer may have to be patient and wait for the action to be offered. It may be tempting to assist the dog at times, but experience indicates that the less assistance given, the faster progress is made.

Note the language here: the trainer waits for the dog to *offer* a desired action. The dog is the initiator of actions, and the trainer is a passive participant who provides rewards when the action is offered. *The dog is in control of the learning process.*

Efficient training requires reinforcement at precisely the right moment. Experience shows that a dog will easily make the link between the sound of the whistle or "clicker" as a reward and the desired action. It may seem frustrating when a dog interrupts desired action to get reinforcement, but a precisely given reward will result in the dog immediately returning to the same situation/action in an attempt to manipulate the trainer to give more "rewards". Timing is essential! Some dogs, as a result of this type of training, become very activated when they understand that their own activities result in reinforcement (see box below). In effect, the dog leads the training process by searching for the actions that the trainer wants to reinforce, and offering them for reward. This is therefore a completely positive experience for the dog.

#### SHAPING WORKS . . . FOR HANDLERS AS WELL AS DOGS

Shaping can even be used to train new dog handlers/trainers as well as dogs. When a dog is being transferred from its trainer to a new dog handler, the original trainer can involve the new handler in the training process using the following procedure.

The clicker is used to communicate with both the dog and the new handler at the same time:

To the dog: CLICK = "yes, that is exactly the action that I want you to give me".

To the new handler: CLICK = "this is the action of the dog that I want you to reward".

The new handler can then offer the reward that the dog associates with the clicker. The problem for a new handler is to practice the principle of timing, which is so important for the reinforcement process to work effectively. Without that practice, the new handler is likely to make many timing mistakes, and could even detract the dog. Thus, the original trainer uses the clicker to improve the observational and timing skills of the new handler, without interrupting the training of the dog.

Shaping is more suited to certain types of training than others. Shaping is particularly suited to a situation where the aim is to form new behavioural patterns, or when training particular aspects of a whole programme.

## Multiple-choice training

*Multiple-choice training* is one of many terms used to describe methods where the aim is to teach dogs to discriminate stimuli by using their sense of smell. An example of such a method has been developed by Fjellanger Dog Training Academy and is described in Chapter 2, Part 2.

The principles of the method were developed with input from both active training and service dog environments (Moulton *et al.*, 1960; King *et al.*, 1964; Military Dog Training Centre Norway, 1978–1981; Craig, 1980; Moulton and Marshall, 1976) and practical experience from work with most types of specially trained sniffer dogs. A number of different apparatus models (Apparatus for Discrimination of Source Material — ADSM) have been designed to organise training so that discrimination of scent substances is optimal for dogs. Shaping is used as a training tool.

The learning methodology avoids development of a dependency between trainer/handler and dog, because the dog controls the learning process and does not need the assistance of a handler for learning to proceed. Behaviour is maintained with no dependence by the dog on the trainer, hence avoiding loss of training effects if the dog is transferred to other handlers. The apparatus may be utilised for an analysis concept such as the REST system, or may be used as a calibration/control tool for the dog's responses to the scent substances to be detected.

## Stimulus discrimination

How do dogs process impressions of the world when learning new skills? The principle involves the development of links between stimuli and actions that are appropriate responses to those stimuli, and is referred to as *discrimination* or *stimulus discrimination*. To organise dog training well, reliable reinforcement is needed to ensure that behaviour is repeatable over different situations and with different caretakers. To have control over the learning process, it is essential that the relevant stimuli be identified and controlled. A dog can learn a skill such as sitting on the command “sit” when in front of the dog handler, but when the handler turns away from the dog and gives the same command, there is no reaction. In this situation, it is likely that body movements and eye contact are the effective stimuli rather than the command. In other words, stimuli other than the command being used by the trainer are being used by the dog to create the action “sit”.

From as early as the very first training session, the dog will be gathering information from all aspects of the environment. Each repeated situation will influence the skills being learned. Initially, replication of the stimulus conditions can be seen as a positive aspect, as the numerous stimuli from the surroundings help to induce the desired behavioural patterns and contribute to quicker progress. Later on, it is preferable for behavioural patterns to be triggered more accurately and by more carefully defined stimuli. In some instances, these may be signals/commands, and in other cases visual



stimuli or odour signals. A central challenge of dog training is to both identify and achieve control over which stimuli trigger the desired response.

Several stimuli occurring simultaneously are often referred to as complex stimuli. Learning processes where complex stimuli form a part of the discriminative stimulus are known as *contextual learning* (Dickinson, 1980). All dog training involving interaction of dog and handler is a form of contextual learning. Research on learning in mazes has shown that animals can establish structural maps of the training/test situation and use these spatial cues as discriminative stimuli influencing their behaviour, rather than using other senses which the trainer may assume are being used (Olton, 1983; Olton and Samuelson, 1976). In another example, the difference in size and lighting of a training/test room affected the training (Gordon *et al.*, 1981). The differences in situation regarding location, time of day, scents, sounds, persons present, etc., are stimuli which affect both dog and handler. The implication is that there must be careful control of the context of learning and of the design of the operational testing apparatus for REST dogs. “Skinner boxes” (Skinner, 1938), and experiments carried out in scent chambers for dogs (Moulton *et al.*, 1960; Waggoner *et al.*, 1997), are situations where the trainers have very precise control over the training conditions. It is not anticipated that such a level of control would be available or even desirable in the training and use of REST dogs.

### *Scent discrimination and threshold for detection: an example of discrimination training*

The anatomical structures used by dogs and humans for detecting and processing odour information are not the same. Detection thresholds of dogs are many times higher than for humans. The biggest anatomical difference is the number of sensory receptor cells (Moulton *et al.*, 1960), which is best illustrated by a comparison of the size of the scent organs. In humans, the scent organs are approximately 5 square centimetres in surface area, whereas for dogs they are 75-150 square centimetres. The cerebral cortex processes information from the olfactory sense. In dogs, about 33 per cent of the entire cortex is used for this task, whereas in humans it is only 5 per cent (Atkinson *et al.*, 1990). In dogs, the high number of cells in the olfactory organ combined with a significant part of the cerebral cortex being used for processing odour information may account for their outstanding skills at discrimination and detection of very low odour concentrations. Attempts have been made to find the lowest threshold that a dog can detect (Moulton *et al.*, 1960; Moulton and Marshall, 1976; Krestel *et al.*, 1984; Phelan, Chapter 5, Part 2), but direct comparisons among these studies are difficult to make because of differences in the methods used. Dogs can be trained to detect odours at vapour pressures well below the detection capability of currently existing chemical detection devices, and lowered detection thresholds can be obtained using training and practice effects (see Chapter 5, Part 2).

The method used for training is important. The choice of reinforcer, amount of training, desired indication signals, system used for sensitisation of odours, etc., are all important factors influencing the end result. The capacity of the sense of smell to detect and discriminate substances varies in the same way as any other physiological function. A better sense of smell is generally attributed to some dog breeds than others (Moulton and Marshall, 1976; Myers and Pugh, 1987). Even within one breed, the sense of smell will vary according to the training and physiological condition of the individual dog. For example, there is proof of impaired sense of smell with various illnesses, e.g.

distemper and Parva influenza (Myers and Pugh, 1987). There may be differences between the sexes (Moulton *et al.*, 1960) and the threshold for detection is thought to reduce when a bitch is on heat (Parlee, 1983).

The physiological function of the olfactory organ can also partly account for the dog's capacity to detect low scent concentrations (Fig. 1). The flow of air through the nasal cavity is controlled via three channels (Miller and Evans, 1993; Fjellanger, 1991). The upper and lower channels determine how the air is carried to the olfactory organ. Air carried through the upper channel (3) is led to the olfactory organ. When the dog starts to sniff (uses its nose to detect a scent), negative pressure gathers in the lower channel (1) so that the air is sucked through the upper channel, over the olfactory organ and down into the choana.

Figure 1  
Sagittal section of nasal cavity (from Fjellanger 1991)

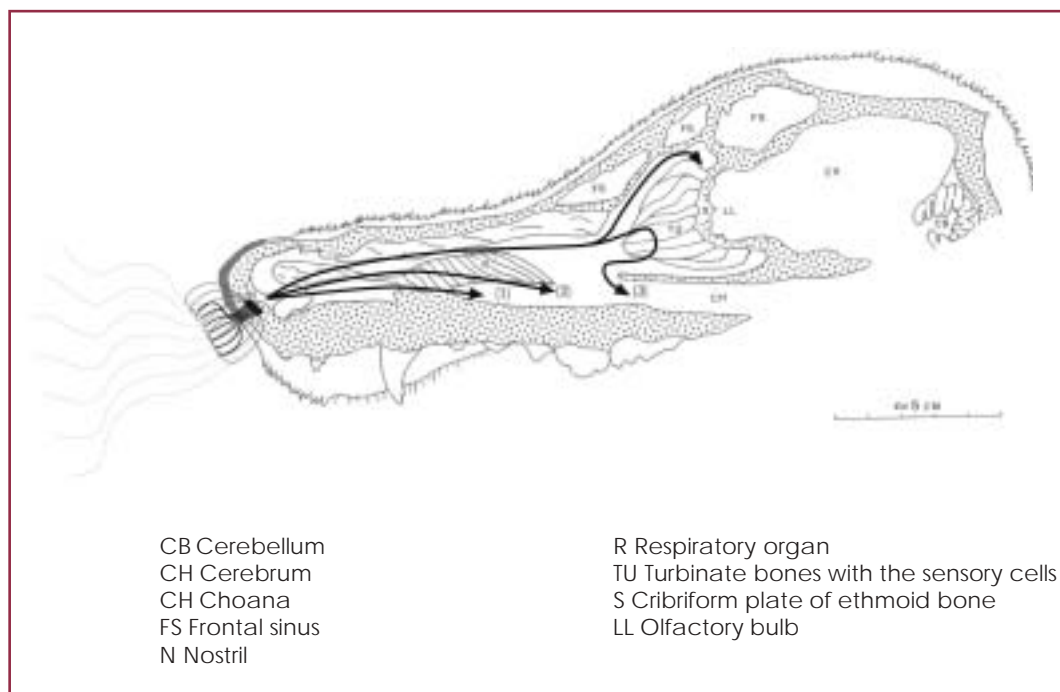

When a dog is sniffing, there is not just a one-way flow of air into the nasal cavity. Each sniff consists of five to seven small inhalations and exhalations per second of about 50 millilitres of air. The air blown out has a high humidity and can gather molecules outside the nose. Because the same air is sucked back in again immediately, any odour molecules that are released by increased humidity are likely to be drawn into the nose. Thus, the operation and physiology of the nose helps to explain the dog's excellent skills in detecting low scent concentrations.

## Reinforcement

*Reinforcement* is a consequence of behaviour that influences the probability or frequency of that behaviour being expressed in the future. The frequency can increase or decrease.

A *reinforcer* is an identifiable stimulus that is detectable by the dog, such as food, praise, etc. To work, the process of reinforcement requires that the dog make a link between the occurrence of the reinforcer and the expression of the behaviour. The timing between these two events is critical.

### *Positive and negative reinforcers*

Reinforcement involves the use of rewards to increase or decrease the probability of an action by a dog. Rewards can be food, a ball, kong (a ball on a short string), or any other objects the dog is fond of, praise, playing, body language expressing happiness, etc. These are all positive things for the dog and will probably *increase* the occurrence of an action. They are therefore referred to as *positive reinforcers*.

Positive reinforcement is very easy to understand. As a result of an action, the dog has a pleasant experience, and so it is more likely to do the action again. If the dog is uncomfortable, due to a positive punishment, it will display this with avoidance. The expression of that avoidance may be something obvious like running away, but where the dog has limited choices (e.g. because it is under the control of the handler) it may also be camouflaged in minor signals in the body language. Examples are yawning, licking round its mouth, pulling back its ears, lowering its tail or lowering its body as it walks. These are all signals of discomfort, and when encountered in training and practical work, are most often a sign that something about the situation is unpleasant for the dog. If the dog acts in a way that reduces the discomfort, then it is improving its current state through avoidance. If it is able to remove the negative feeling, this will work as a negative reinforcer (the removal of a discomfort) and as such lead to an increased probability of the action being repeated. The process is referred to as *negative reinforcement* of behaviour.

An example: the dog is asked to search a set of filters where the handler does not know the location of the targets. The dog is uncomfortable with the situation because it is sick today. The handler forces the search using aggressive voice, staring at the dog, or jerking on the lead. The dog has limited choices because it is on lead and is under pressure to search. The dog knows from previous experiences that an indication will result in an end to the search. The dog gives an indication at a randomly chosen filter. From the handler's point of view this is an operational situation, and it must be assumed that the indication is real. From the dog's point of view, the search ends and the negative experiences of voice, jerking etc., are all removed, which is why this scenario is about reinforcement. The effect of this example will be to *reduce* the quality of search expressed by the dog, to make the dog feel uncomfortable in the presence of the handler next time, and to increase the occurrence of false indications (= *reduced* correct indications).

### *Distribution of reinforcement — intermittent reinforcement*

When an action is reinforced every time it occurs, the process is known as *continuous reinforcement*. When an action is repeated several times before the reinforcer is activated, the occurrence of the reinforcer is intermittent and the process is called *intermittent* or *occasional reinforcement*.

A fundamental principle of learning theory is that intermittent reinforcement is more effective at maintaining a response than is continuous reinforcement. Rewarding a

behaviour every time it occurs produces an expectation by the dog that the reward will appear whenever the action is offered, which is effective in inducing new behaviours. After such a training procedure, just one occasion of the action being offered by the dog without being rewarded will lead to a reduction in the likelihood of the action being offered again.

In a typical dog training situation, the occurrence of a desired behaviour (e.g. sitting on command) will be established by reinforcing the dog every time it sits. However, once the behaviour is given consistently to the command, the appearance of the reward becomes less reliable. The dog may be rewarded every third time it sits on command, or even better, it is rewarded after a variable number of times of sitting on command. Initially, the reward will still appear rather often (e.g. after 2, 1, 3, 1, 1, 2, 1, 3, 1, 1, 4, 1, 2, 1 times). But as training goes on and the dog is offering the behaviour reliably without the reward being provided, the rate of appearance of the reward can continue to be decreased (e.g. after 5, 3, 6, 2, 7, 4, 8, 1, 9 times). This is called *variable frequency (ratio) reinforcement*.

However, a trainer of a search dog has to deal with a different kind of behaviour – a behaviour that is continuous in time (e.g. searching) rather than a discrete action (e.g. sitting). A primary training aim will be to extend the search intensity of the dog in time. This problem must be dealt with by adjusting the reward rate in time. To extend search intensity, the trainer will maintain a record of the period that the dog searches for without interruption, and the training aim will be to extend that average period of search. For example, if the dog naturally exhibits search behaviour without becoming distracted for an average of 30 seconds, then the aim could be to increase that length of time to an average of one and a half minutes over the next few training sessions. Initially, the reward will appear quite often in time, say at an average rate of every 30 seconds because the dog already searches reliably for that period of time (e.g. after 10, 20, 70, 30, 20, 50, 60, 10, 30, 10, 20 seconds). Then the next two sessions could be 60-seconds average (e.g. 40, 80, 30, 90, 60, 20, 100, 60 seconds) and 90-seconds average (e.g. 50, 140, 80, 100, 10, 170, 110, 70, 90 seconds). Now, the search intensity of the dog is being maintained for an extended period of time relative to the original natural search behaviour. This is called *variable interval reinforcement*.

The amount of time spent searching can be thought of as “number of filters checked by a REST dog”. If in one minute, the dog will check six filters, then in one-and-a-half minutes it can check nine filters. The dog checks filters at a standard rate, so the method used to increase the search time of the dog will be to increase the number of non-target filters to be checked. Here, number of filters can be equated with time of searching, because more filters = more time searching, and a bigger number of negative targets between the positives = extended maintenance of searching behaviour. Note that the principle of unpredictable appearance of the reward described in the first scenario also applies to this second scenario of rewards being offered in time. It is the *average* time of search between finding a positive that is slowly extended by the trainer, but the appearance in time of *each* positive is quite variable, as indicated in the numbers used in the example in the paragraph above.

### SHAPING, WITH A CLICKER

A clicker is a little plastic tool with a steel tension spring that produces an audible two-tone clicking sound when pressed. The clicker has been used in dog training for some years, and the sound (click) has been established as a conditioned stimulus with the shaping method of training. The dog responds to the click and the clicker can therefore be used as a signalling tool.

1. Press the clicker to produce a two-tone sound. Give the dog a titbit, in small portions. Give the dog something especially tasty at the start, for example, small morsels of fried chicken or liver, rather than large pieces of dried food.
2. Click when the dog does something you want it to do. Start off with something simple, preferably something the dog would want to do independently (e.g. sit, come to you, sniff randomly, raise its paw, walk at heel).
3. Click exactly when the dog is behaving the way you want, not afterwards. Click only once (in-out). The timing of the click is decisive. Do not worry if the dog stops what it was doing when it hears the click, this is only natural. Give the dog the titbit afterwards, the timing of this reward is not as important.
4. Click when you notice the dog consciously (or coincidentally) beginning to behave in the way you want. It may be tempting to help the dog do as you want or move where you want, but the less help you give, the quicker the dog will progress. You can of course try to help to a certain degree, but train the dog to manage without help as quickly as possible. Your aim is to have the dog offer behaviours to you in the hope of getting you to reward it.
5. Train for short periods only. A dog can learn a lot more in five minutes than over one hour of boring repetitions. You can achieve notable results and teach your dog a whole range of new things by using just a few clicks during the day, as a part of your normal routine. Always have the clicker with you and seize upon opportunities when the dog begins doing behaviour that you want to see repeated.
6. Clicker training is most simple in practice when you start off with things the dog already does: sitting, lying, coming to you, or walking at heel. If you click as soon as or immediately after the dog has acted as you want, then the dog will repeat the behaviour more often.
7. Do not wait for the dog to complete its action or behaviour. Click and give a reward for small movements in the right direction. If you want the dog to sit, and it starts to lower its haunches, then click. If you want it to come to you, and it takes a few steps towards you, then click. This is what is known as shaping behaviour.
8. When a dog has learnt to do something to make you click, it will start to repeat this behaviour spontaneously (i.e. is offering the behaviour) to get you to click. It will do something then look directly at you as if to ask: "Was that right?"
9. If it is a minor activity, you can increase interest by varying the type of reward you use, sometimes with a titbit, other times a pat, ball or game. If you want to let the dog know you are especially happy with its behaviour, then increase the number of titbits and show your pleasure in your body language – do not use the clicker more often.
10. Once a behaviour is established, reduce your reward rate (i.e. the rate at which you give the clicker reward) so that the offering of the behaviour is only being rewarded intermittently. Now the dog will offer the trained behaviour, but will also be motivated to offer new behaviours, which you can also potentially reward.

11. Stop a training session when things are going well, or you have reached a new level, or when the dog is performing perfectly.
12. Abolish unwanted behaviour by clicking for the behaviour you want. Instead of shouting at the dog for barking, click when it is quiet. Stop the dog pulling at its leash by clicking and giving a reward whenever the leash falls slack.
13. Once the dog is offering the behaviour reliably, it is time to introduce an additional signal, such as a word or sign with the hand, to link the behaviour to a command. Give the signal directly before or at the same time as you click for correct behaviour. Ignore correct behaviour when offered without you giving the signal.
14. Do not attempt to demand that the dog offers behaviours. Clicker training is not about commanding the dog. The notion of a command is that it is a convenient signal for you to use in the future to communicate with the dog. If the dog does not react to the signal, it is not "disobedient", it just has not learnt the signal properly yet. Continue the training by finding new locations (persons, times), give the signal and click for correct behaviour.
15. If you become irritated, put the clicker down. Do not confuse shouting, pulling the leash and correction, with clicker training. You will only break down any relationship between you and the dog, and the dog's interpretation of the clicker.
16. If you get no results, then change strategy – remember there are many "roads to Rome". Often the timing is wrong, you may be clicking too late. Get someone who understands the clicker training principle to watch you, or maybe even help use the clicker.
17. Most importantly, clicker training is a great way to enhance your relationship with your dog. Have fun!

---

Taken from the book: Fjellanger, R., P. J. Matre, R. Kylling (2000) *Hundens beste venn – læring og samspill ..... med det gode*, H.A.L.S. Forlag.

## References

- Atkinson, R. L., R. C. Atkinson, E. E. Smith, D.J. Bem and E. R. Hilgard (1990)  
*Introduction to psychology*, Harcourt Brace Jovanovich Publ., San Diego.
- Bandura, A. (1986)  
*Social Foundation of Thought and Action - A Social Cognitive Theory*, Prentice Hall, London.
- Catania, C. (1992)  
*Learning*, Prentice Hall, New York.
- Craig, D. (1980)  
Unpublished materials and personal notes.
- Dickinson, A. (1980)  
*Contemporary animal learning theory*, Cambridge University Press, Cambridge.



- Fjellanger, R. (1991)  
*Utvikling av metode for bestemmelse av lukteterskel hos hund*, Fysiologisk Institutt Universitetet i Bergen, Bergen.
- Gordon, W.C., K.M. McCracken, N. Dess-Beech and R.R. Mowrer (1981)  
“Mechanisms for cueing phenomenon: The addition of the cueing context to the training memory”, *Learning and Motivation* 12:196-211.
- King, J. E., R. F. Becker and J. E. Markee (1964)  
“Studies on olfactory discrimination in dogs: (3) Ability to detect human odour trace”, *British Journal of Animal Behaviour* 12(2-3):311-315.
- Krestel, D., D. Passe, J. C. Smith and L. Jonsson (1984)  
“Behavioral determination of olfactory thresholds to amyl acetate in dogs”, *Neuroscience & Biobehavioral Reviews* 8:169-174.
- Miller, M. E., and H. E. Evans (1993)  
*Miller's anatomy of the dog*, 3rd ed., W. B. Saunders, Philadelphia.
- Moulton, D. G., E. H. Ashton and J. T. Eayrs (1960)  
“Study in olfactory acuity. 4. Relative detectability of n-alipatic acids by dog”, *British Journal of Animal Behaviour* 8(3-4):129-133.
- Moulton, D. G., and D. A. Marshall (1976)  
“The performance of dogs in detection a-ionone in vapor phase”, *Journal of Comparative Physiology* 110:287-306.
- Myers L. J., and R. Pugh (1987)  
“Normative olfactory thresholds in the dog determined by electroencephalographic and behavioural olfactometry”, *American Journal of Veterinary Research* 46:2409-2412.
- Olton, D. S. (1983)  
*Memory Function and the Hippocampus*, The Johns Hopkins University, Baltimore, Maryland, U.S.
- Olton, D. S., and R. J. Samuleson (1976)  
“Remembrance of places passed: Spatial memory in rats”, *Journal of Experimental Psychology: Animal Behavior Processes* 2:97-116.
- Parlee, M. B. (1983)  
“Menstrual Rhythms in Sensory Processes: A Review of Fluctuations in Vision, Olfaction, Audition, Taste and Touch”, *Psychological Bulletin* 93(3):539-548.
- Pryor K. (1999)  
*Don't Shoot the Dog*, Bantam Books, New York.
- Skinner, B.F. (1938)  
*The Behavior of Organisms*, B.F. Skinner Foundation, New York.
- Waggoner, L. P., J. A. Johnston, M. Williams *et al.* (1997)  
“Canine olfactory sensitivity on cocaine hydrochloride and methyl benzoate”, *SPIE Proceedings* 2937 (2):216-226.

## Chapter 1

### Perspectives on animal learning theory

# Part 3

# Principles of animal learning

Stewart Hilliard

## Summary

The objective of this section is to summarise some of the main principles of animal learning, and to make these principles immediately relevant to the training of working dogs. Familiarity with the basics of animal learning will give the working dog trainer new names to apply to training procedures. More importantly, understanding of learning principles allows the trainer to adapt training to suit the individual dog, to understand why a given method is not working, and to understand how one lesson influences the dog's ability to learn the next. Above all, it is my hope that an appreciation of the psychological processes underlying training will move the reader away from the emphasis on physical force and punishment that has characterised training of working dogs throughout much of its history.

This theoretical perspective on working dog training emphasises the processes of habituation, classical and instrumental conditioning, and extinction.

*Habituation* is the gradual loss of responsiveness to a stimulus as a result of repeated exposure to that stimulus. In order to produce effective habituation (of, for example, a fear-eliciting stimulus like a loud noise), the trainer should present the stimulus in a weakened form until the dog exhibits little fear. Then the trainer should gradually increase the stimulus intensity until the dog exhibits little fear to the stimulus even at full strength. The stimulus presentations and training sessions should be well separated in time.

*Classical conditioning* is a process in which the dog learns to associate two environmental stimuli. One is a relatively weak stimulus such as a noise or a voice cue (called the conditioned stimulus, or CS). The other is a powerful stimulus (called the unconditioned stimulus, or US) such as food or a sharp collar correction. As a result of repeated pairings of the two stimuli, the CS elicits a response (the conditioned response, or CR) that was formerly elicited only by the US. Classical conditioning does not involve rewards or punishments,



but involves the dog developing an involuntary response to the predicting stimulus. Thus, a dog learns to salivate and become excited when it hears the ring of its food pan in the cupboard, or it learns to cringe and feel anxiety when it hears the word "No!". Classical conditioning principally involves learning reflexive and emotional reactions, such as likes and dislikes, attitudes towards the handler, work, and training. Forward conditioning, in which the CS precedes the US by a second or less, is the most effective procedure for classical conditioning.

Dog training seldom involves deliberately-staged classical conditioning procedures, but dogs are inevitably presented with CSs and USs as a part of their experiences and learn to associate current with future stimuli (such as tension in the handler's arms followed by a jerk on the collar). Classical associations can be exploited by the handler, for example by eliciting excitement using the cue "Ready to work?" (signaling a forthcoming ball reward). Classical associations can also interfere with training objectives, for example when the dog freezes instead of sitting in response to the "Sit!" command (because the command is often followed by a collar correction).

During *instrumental conditioning*, the dog learns to associate a voluntary behaviour (the instrumental response) with its result (the consequence). Reinforcers are consequences that encourage prior behaviour, while punishers are consequences that discourage prior behaviour. Behaviour is reinforced either by giving the dog something pleasant, or by withdrawing or omitting something unpleasant. For example, a sit will be followed by a piece of food (reward, or positive reinforcement), or releasing the ball on command will *prevent* a collar correction (negative reinforcement). Behaviour is punished either by giving the dog something unpleasant, or by withdrawing or omitting pleasant stimuli. For example, breaking the down-stay will be followed by a bump on the nose (punishment, or positive punishment), or jumping up on the handler will *not* be followed by petting and attention (omission, or negative punishment). Each of these relationships between a response and a consequence is called a response rule. Commands, such as "Sit!" and "Out!", are cues telling the dog what response rules are currently in force.

To reward an episodic behaviour (such as barking on command), a continuous reward schedule (CRS, the reward appears after every correct repetition) is used initially. Once the dog has learned the skill, it is trained to repeat the response a few times by using fixed ratio reward schedules (FRRS, the reward appears reliably after gradually increasing numbers of repetitions). Once the dog readily repeats the response, variable ratio reward schedules (VRRS, the reward appears variably or after unpredictable numbers of correct repetitions) are used to make performance persistent. To reward continuous behaviours (such as maintaining a down-stay or continuous searching for target odour), fixed interval reward schedules (FIRS, the reward appears at gradually increasing intervals of correct performance) are used initially. Once performance has been extended, variable interval reward schedules (VIRS, the reward appears at random or unpredictable intervals of correct performance) are used to make performance persistent. Random reward is the most effective procedure for creating steady and consistent responding, and it also renders that responding highly resistant to extinction.

Training using pleasant stimuli as consequences (i.e. rewards to encourage or omission to discourage behaviour) is inductive methodology, best for establishing a working relationship with a dog, for teaching the dog a positive attitude towards work, and for teaching most of the basic skills and

commands. Training using unpleasant stimuli as consequences (i.e. negative reinforcement to encourage or punishment to discourage behaviour) is compulsive methodology, used to produce more reliable or precise performance once behaviours have been established. For compulsive training to be effective, the dog must already have a good understanding of how to perform the target behaviour prior to being *forced* to perform it using compulsion. Negative reinforcement training normally proceeds through two distinct phases, escape and avoidance. During escape training (consisting of one or only a very few repetitions), the dog learns that it can “turn off” an unpleasant stimulus by engaging in a particular response. If the dog does not understand the escape behaviour or does not have the ability to carry it out, then further attempts at negative reinforcement training could be disastrous. At best, the dog will learn to dislike work and to distrust the handler; at worst, it could become fearful or aggressive. During avoidance training, the dog learns that by responding to a cue (such as the “Out!” command) it can avoid the unpleasant stimulation altogether.

Classically- and instrumentally-conditioned behaviours can be extinguished. Extinction of an undesirable classically-conditioned response (e.g. anxiety in response to a correction collar being placed on the neck) involves presenting the CS repeatedly until the CR disappears. To extinguish an undesirable instrumentally-conditioned response (e.g. jumping up on the handler for attention), the response is placed on an extinction schedule by allowing it to occur repeatedly without providing any reinforcement.

Classical conditioning does not involve rewards or punishments, but involves the dog developing an involuntarily response to the predicting stimulus. Thus, a dog learns to salivate and become excited when it hears the ring of its food pan in the cupboard, or it learns to cringe and feel anxiety when it hears the word “No!”. Classical conditioning principally involves learning reflexive and emotional reactions, such as likes and dislikes, attitudes towards the handler, work, and training. Forward conditioning, in which the CS precedes the US by a second or less, is the most effective procedure for classical conditioning.

## Introduction

Fundamentally, the task of the detector dog trainer is to teach the animal two lessons. First, the animal must learn an association between a target odour and some highly rewarding stimulus, and second, it must learn to give a specific response in order to gain access to that reward. The association between the target odour and the reward induces the animal to search for the target substance, while the instrumental response provides an “indication” alerting the handler to the presence and location of the target. These two lessons are mediated by different learning processes that have been studied by experimental psychologists for about 100 years. These studies have revealed better ways to bring about learning in animals and human beings, but it has been only

relatively recently that scientific knowledge about animal learning has been applied to working dog training.

## Animal learning

Learning is a more or less permanent change in the behaviour of an organism as a result of interaction with the environment. (The terms learning and conditioning are here used to mean the same thing.) This definition distinguishes learning-based behaviour change from short-term behaviour changes such as sensitisation, fatigue, and sensory adaptation. For the purpose of dog training, it is sufficient to discuss three types of learning — habituation, classical conditioning, and instrumental conditioning.

### *Habituation*

Habituation is a gradual decrease in responsiveness to a stimulus as a result of repeated exposure to that stimulus. For example, the first time a dog hears a door slam it may startle. In all likelihood, when it hears this slam again and again, it will gradually startle less and less until, finally, it exhibits little response to the noise. Habituation is adaptive because it allows the dog to save its attention for important stimuli, such as the noise of the lid coming off the dog-food can. Habituation takes place continually during dog training, in ways that are both advantageous and disadvantageous to the dog trainer.

### *Advantageous habituation*

In some situations, habituation may improve the dog's effectiveness. Dogs are normally to some extent frightened of, or interested in, things that are new to them. However, detector dogs are expected to carry out their duties in environments that feature very distracting and sometimes intense stimuli, such as taxiing airplanes and loud explosions. Through habituation, a working dog can learn to respond minimally to irrelevant stimuli and pay attention to the "job". For example, a detection dog trained entirely in quiet, vacant barracks may initially have difficulty concentrating on a search task when commanded to "clear" a building with people inside it. However, once the dog becomes habituated to an environment full of people, its ability to concentrate on the task will improve.

Habituation proceeds most effectively and rapidly with stimuli that are mild or moderate in intensity. It can be very difficult to produce habituation to intense or frightening stimuli. A fearful dog exposed repeatedly to a very intense stimulus, such as a running helicopter engine at close range, is likely to respond *more* intensely to this stimulus over time instead of less intensely.

In addition, habituation is most efficient when the stimulus exposures and training sessions are well separated in time. For example, a dog habituates more easily to gunshots when they are spaced out at intervals of 15 or 20 seconds, and when the training sessions are separated by 24 hours. The opposite procedure, exposing the dog to rapid series of gunshots several times a day, may lead to increased fear of the noise.

When habituation is conducted with mild stimuli spread through time, undesirable responses such as fear tend to weaken or even disappear.

**Hierarchies of stimulus intensity.** Although habituation proceeds most easily with stimuli that are very mild, mild stimuli are rarely a problem in dog training. Instead the stimuli that disrupt the dogs' performance by inducing fear and anxiety are often very intense, such as gunshots or running jet engines. However, habituation to even very intense or frightening stimuli can be achieved using a hierarchy of intensity — a scale on which stimulus intensity increases gradually from low to high. A practical way to decrease the intensity of noise stimuli is by exposing the dog to them from a great distance. For example, the dog is first presented with the sound of a running jet engine at a distance of 500 metres, where it exhibits only mild anxiety. Once this anxiety disappears through habituation, then the dog is moved to the next level in the hierarchy by walking to within perhaps 400 metres of the jet engine. Once any anxiety responses have habituated, then the handler moves the dog closer, and so forth. By introducing the dog to frightening stimuli at a level of intensity that is so low that it provokes little or no fear response, and by moving gradually from one stage on the hierarchy of intensity to the next, the trainer trains the dog to exhibit little fear in the presence of even very intense stimuli.

**Counterconditioning.** Habituation can be accelerated by pairing a strong pleasant stimulus with the fear-inducing stimulus. To again use the previous example, if the dog is frightened of a running jet engine, its fear can be offset by presenting the dog with a strong pleasant stimulus like food or a ball. This procedure is called counterconditioning, and should be combined with the use of hierarchies of intensity. This is because, if the dog is very afraid of the jet engine, it will ignore the food or a ball when it is close to the engine — it will be too afraid to eat or play. Therefore counterconditioning is conducted at distances progressively closer and closer to the engine, beginning at a distance great enough so that the dog's anxiety is easily offset by its pleasure at being presented with food or a ball. At each stage of the hierarchy (i.e. distance from the jet engine), it is essential that the trainer uses the dog's behaviour as the measure of when to proceed to the next stage, so that counterconditioning proceeds at a pace suited to the individual dog. Moving too quickly "up" the hierarchy (i.e. closer to the jet engine) will not produce reduction in fear, and could even countercondition the food or ball, reducing the dog's pleasurable response to these motivators. (*Note: Counterconditioning is actually a form of classical conditioning — to be explained below — but it is introduced here for the sake of continuity in discussion of methods of fear-reduction.*)

**Spontaneous recovery.** Fear responses are very durable and persistent and can re-emerge even after extensive habituation "therapy". This is because habituation includes certain short-term processes that "wear off" after a few minutes or hours, and it is normal for a habituated response to re-appear to some extent between training sessions. Thus, a dog may exhibit no fear of a stimulus by the end of one day's training session, yet show recovered fear at the beginning of the next session. This phenomenon is called spontaneous recovery. For example, a dog habituated to a loud noise like an air compressor (i.e. shows no fear), may display some fear the next time it encounters the compressor. It is important to understand that even when habituation and counterconditioning are correctly applied, the fear response will often re-emerge. However, from session to session there should be less and less spontaneous recovery of the fear response.

**Disadvantageous habituation.** Habituation may decrease rather than increase the dog's effectiveness because effective performance in a working dog depends upon a certain level of interest in, and responsiveness to, environmental stimuli. A dog that is relatively new to detection work may deliver very intensive and focused search behaviour because it is stimulated and excited by the new learning situation. But after more experience, the dog may become sluggish and appear "bored". The best weapon against this disadvantageous habituation of the dog's enjoyment of its work is to inject as much variety as possible into the dog's daily routine. For instance, a detector dog should be trained in as many different locations as possible, and a variety of different reward objects and games should be used as reinforcers. In addition, spontaneous recovery can be used to assist training — if the dog is not worked for a period of time there should be some recovery in its enjoyment of work.

### *Classical conditioning*

Classical conditioning is the learning of emotional and reflexive responses through the formation of mental associations between stimuli. For example, a dog can learn fear of a veterinary clinic in the following way: If the dog has never before been in the clinic, the stimuli of the clinic (such as its look, smell, and sound) should be neutral or meaningless. However, after the dog is restrained by technicians and injected with a needle, it may associate the look, smell, and sound of the vet clinic with physical restraint and the pain of the injection, so that the next time it is taken in for a procedure the clinic stimuli are no longer neutral — they will elicit the same fear that physical restraint and injection do.

In classical conditioning (also called Pavlovian conditioning, Fig. 1) the dog learns a relationship between two events, or stimuli. One of these stimuli is a "neutral" or unimportant stimulus that a dog would normally pay little attention to. This stimulus is called the conditioned stimulus, or CS, because it can generate strong behaviour only as a result of conditioning. The other stimulus is a biologically important stimulus that a dog naturally pays a lot of attention to — like food. This stimulus is called the unconditioned stimulus, or US, because it can generate strong behavioural responses without any conditioning.

Figure 1  
The structure of classical conditioning

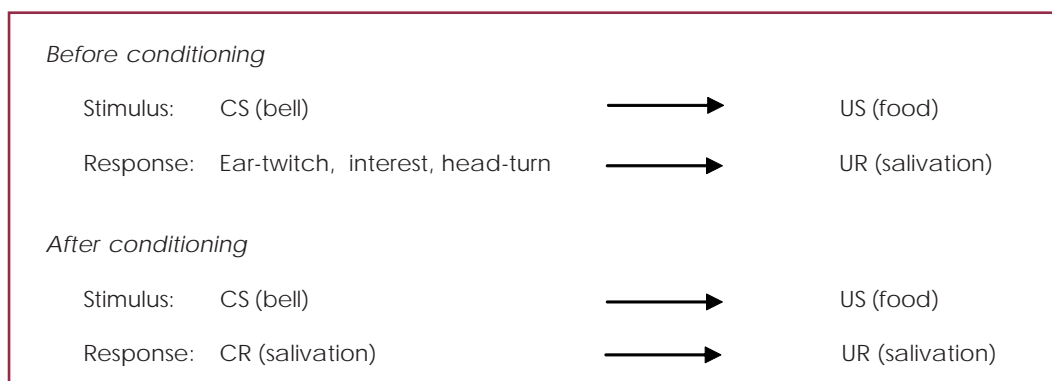

In the classical example, the Russian scientist Ivan Pavlov taught dogs to salivate in response to the ringing of a bell. Pavlov did this by repeatedly pairing a bell (CS) and some food (US), presenting them close together in time. A naive dog normally responds to the ringing of a small bell by merely twitching its ears or looking towards the noise. However, a piece of food can cause the dog to show a great deal of strong behaviour like excitement, salivation, digging and pawing, chewing and eating. This very strong behaviour caused by exposure to a US is called the unconditioned response, or UR. Through classical conditioning, the CS and the US become associated in the dog's "mind", so that behaviour that is naturally triggered by the US (the UR) comes to be triggered to some degree by the CS also. When a CS develops the ability to trigger behaviour that is normally caused by a US, this learned response is called the conditioned response, or CR. Thus, eventually Pavlov's dog learned that the bell predicted food, and began to salivate in response to the bell (CR).

### Applying classical conditioning

The most effective procedure for classical conditioning involves presenting the neutral stimulus/command (CS) immediately *before* the biologically important stimulus (US). Thus, if the handler wishes to train the dog to feel startled and anxious in response to the word "No!" then an effective method would be to wait until the dog engages in some misbehaviour like sniffing the trash. The handler then gives the "No!" cue, and throws a chain choke collar against the trash can so that it makes an unpleasant sound about half a second after the "No!". Originally the word "No!" (CS) means little to the dog and produces little change in behaviour. The unpleasant noise (US) is potent and causes a strong startle or freezing response (UR). Pairing the "No!" with the unpleasant noise teaches the dog to startle/freeze in response to "No!" (CR) within one or a very few CS-US pairings. Later, when the dog is engaged in misbehaviour, the handler can use the "No!" command, causing the dog to startle/freeze (which serves to interrupt the undesirable activity), and the handler can then recall the dog and praise it. The dog will soon learn to shy away from behaviours and objects when it hears the "No!" command (classical conditioning) and return to its handler for praise (instrumental conditioning — see below).

When the CS and the US are reversed, so that the US precedes the CS, this is called a *backward conditioning* procedure. Little or no learning takes place during backward conditioning. Thus, even many repetitions of a training trial in which the dog is startled with a loud noise and then hears a "No!" may not produce a startle response when "No!" is given by itself.

### Extinction of classically-conditioned responses

Not everything a dog learns through classical conditioning is desirable. For instance, if a harsh correction is given the first time a chain choke collar is placed on the dog, the animal will probably show inhibition and anxiety the next time a chain collar is placed on its neck. Undesirable classically-conditioned responses can be weakened or even abolished by presenting the CS repeatedly without pairing it with the US, causing the CR to gradually decrease in strength. This process of *extinction* is just like habituation, except that in habituation an unlearned response is gradually abolished, whereas in extinction a learned response is gradually abolished.

For example, suppose a dog has been trained to become aggressive when it hears gunfire (by association of the sound of gunshots with the opportunity to bite), but in



its new job as a detection dog this response is undesirable. Here, a previously trained response has become a behaviour problem. The remedy is not simple, but a first step is to produce some extinction of the aggressive response by putting the dog in a neutral situation and firing a gun repeatedly until the animal's arousal response to the gun decreases.

Extinguishing a learned behaviour does not mean that it has been unlearned or "erased", even though the behaviour may no longer be expressed. Learning can produce permanent changes in the brain that are not reversed by extinction. Thus, a behaviour thought to be "extinct" may suddenly reappear, especially with a change in the context (environment) of training.

### *Instrumental conditioning*

Instrumental conditioning is the learning process through which an animal's behaviour is changed by the consequences, or results, of that behaviour. For example, if a puppy approaches and sniffs a cat, and the cat spits and scratches the puppy's nose, the puppy is less likely to approach the next cat it sees. The behaviour, approaching cats, has been modified by its consequence, a startling and painful experience. This is an example of punishment. A contrasting example: if a dog chews at the door of its crate and the crate bursts open, then the dog is more likely to chew at the crate in the future. The behaviour, crate chewing, has been modified by its consequence, freedom. This is an example of reward, also called reinforcement.

In both examples of instrumental learning above, an association is formed between a behaviour and a stimulus, and this is a central distinction between instrumental conditioning and classical conditioning. Classical conditioning involves formation of an association between two stimuli, as in the CS-US association between the "No!" and an unpleasant stimulus like a collar correction, described above. Instrumental conditioning procedures emphasise formation of a response-stimulus association, for example between the act of sitting and some pleasant stimulus like a piece of food.

### *Instrumental conditioning model*

Four elements are involved in an instrumental conditioning procedure:

- First, is some *response* on the part of the dog; usually some skeletal response (so-called because it employs the voluntary or "skeletal" muscles) such as sitting, lying down, or barking.
- Second, is the *consequence*, or result of that response. Examples include a scratch on the nose and freedom from the crate.
- Third, is the *response rule*, the law that links the dog's response to the consequence (also called a response contingency). For example, common response rules in dog training are the following: a sit is followed by praise; releasing a ball prevents a collar correction; breaking a down results in a collar correction. More than one response rule can, and usually does, apply to any given target behaviour. Thus, in traditional dog training methods, the down exercise often involves four response rules: (1) lying down results in a reward such as praise, and (2) the reinforcement of not being corrected; (3) not lying down results in the punishment of being subjected to a jerk on the collar, and (4) the punishment of not receiving praise.
- Fourth (even though in practice it usually comes first), is a cue or *command*. Commands are signals (also sometimes called discriminative stimuli) that tell

an animal when a particular response rule is in effect. The handler will not reward a sit anytime the dog sits, but only when a sit response is desired. The command “Sit!” tells the dog that one or more response contingencies are in force — for instance, a prompt sit will result in petting and praise and the omission of a collar correction, while refusing to sit will result in no petting or praise and the administration of a collar correction.

### Consequences

There are two main categories of consequence in instrumental conditioning procedures— *reinforcement* and *punishment*.

**Reinforcement** is a consequence that encourages or strengthens prior behaviour. Examples of reinforcers are food, access to a toy, or a pat on the head. Any of these, when given to the dog after it sits, tends to strengthen sitting behaviour. Food, toys, and pats on the head are reinforcing because they are pleasant. These kinds of consequences are called “positive reinforcers”. However, unpleasant events can also act as reinforcers. For example, the handler can reinforce a behaviour by means of an unpleasant event like a jerk on the leash, *by withholding the jerk when the dog sits*. In this example, there is a negative response rule between sitting behaviour and a jerk on the collar — if the dog sits, there will be no jerk. Although the jerk itself is unpleasant, the absence of the jerk is a “satisfying state of affairs” and will, under proper circumstances, serve to reinforce sitting behaviour. This kind of reinforcer is called a “negative reinforcer”.

**Punishment** is a consequence that discourages or weakens prior behaviour. Examples of punishers are jerks on the collar (collar corrections) or bumps on the nose. Either of these, when administered to a dog after it misbehaves by, for example, breaking the down-stay position without permission, will tend to weaken down-stay-breaking behaviour. Collar corrections and bumps on the nose are punishing because they are unpleasant. These kinds of consequences are called, paradoxically, “positive punishers”. However, pleasant events can also act as punishers. The handler can punish an undesirable behaviour by withholding or taking away a pleasant stimulus like praise and petting. For example, if the dog tends to jump up on the handler when it is excited, jumping up can be punished by withholding praise and attention. In this example, there is a negative response rule between jumping-up behaviour and praise and petting — if the dog jumps up, it will not receive praise or petting. Because the praise and petting are pleasant, their absence is an “unsatisfying state of affairs” and will, under the proper circumstances, punish jumping-up behaviour. This is called “negative punishment”.

**Use of the terms “positive” and “negative”.** The terms positive and negative help define the four possible consequences of an instrumental behaviour — positive reinforcement, negative reinforcement, positive punishment, and negative punishment. However, “positive” and “negative” used in this sense have nothing to do with whether the procedure is pleasant or unpleasant for the dog. A commonly misused expression is “negative reinforcement”, because non-psychologists interpret the word “negative” as meaning bad or unpleasant. Thus negative reinforcement is commonly used as though it was synonymous with physical punishment, but it is not. The terms positive and negative in this context actually refer to the nature of the response rule (also referred to as a contingency) between the dog’s response and the consequence.



In relation to the notion of contingency:

- The adjectives “positive” or “negative” do not indicate whether the procedure involves applying discomfort to the dog.
- It is possible to reinforce a behaviour by means of either stimuli that the dog likes (by applying these stimuli to the dog immediately after the behaviour), or stimuli that the dog does not like (by removing or omitting these stimuli immediately after the behaviour).
- It is possible to punish a behaviour by means of either stimuli that the dog likes (by removing or omitting these stimuli immediately after the behaviour) or stimuli that the dog does not like (by applying these stimuli to the dog immediately after the behaviour).

The following simple language summarises the review above:

- *Reward (positive reinforcement)* encourages a response by giving the dog something it likes immediately after the response.
- *Punishment (positive punishment)* discourages a response by giving the dog something it dislikes immediately after the response.
- *Negative reinforcement* (no synonym) encourages a response by taking away from the dog something it dislikes immediately after the response.
- *Omission (negative punishment)* discourages a response by taking away from the dog something it likes immediately after the response.

## Primary and secondary reinforcement and punishment

Many rewards and punishments are biologically powerful stimuli, such as the opportunity to eat or a painful jerk on the collar. In the language of classical conditioning, they are called unconditioned stimuli (USs). In the language of instrumental conditioning, they are called primary reinforcers or primary punishers. Dogs respond readily and strongly to these stimuli without having to be taught to do so. However, some rewards and punishments originally have little effect on a dog's behaviour. Called secondary reinforcers and punishers, they do not become effective until they have been associated with primary reinforcers or punishers.

Secondary reinforcers gain their ability to strengthen and encourage behaviour by being associated (through classical conditioning processes) with primary reinforcers. For instance, puppies probably do not instinctively enjoy being spoken to. They learn to like being spoken to in a happy voice because this voice is associated with physical petting and with the presentation of food. After enough of this conditioning, words like “Good!” spoken in a happy voice become pleasant stimuli. Subsequently, the word “Good!” has the power to reinforce prior behaviour (if the handler says “Good!” immediately after the dog executes the behaviour).

Secondary punishers gain their ability to weaken and discourage behaviour by being associated with primary punishers. For instance, the word “No!” (spoken in a neutral tone) means nothing to an untrained dog. The word becomes unpleasant because it is associated (through classical conditioning) with unpleasant primary punishing events like a jerk on the collar. After enough of this conditioning, the command “No!” becomes an unpleasant stimulus. Subsequently, the word “No!” has the power to punish prior behaviour (if the handler says “No!” immediately after the dog executes the behaviour).

## Systems of instrumental training

So far, instrumental procedures have been classified in terms of whether they are reinforcing or punishing. Another useful way to classify instrumental procedures is in terms of whether they are inductive or compulsive; that is, whether they use pleasant or unpleasant consequences to motivate and teach the dog.

### *Inductive training*

In inductive training the handler relies on the use of pleasant events and stimuli to obtain desirable behaviour from the dog. For instance, a dog can be taught to put its feet up on a wall by using a piece of food to entice it up onto the wall, and then letting it eat (reward). Or, a puppy can be taught not to cry in its crate by refusing to open the crate when the puppy is crying (omission). The root word “induce” means to persuade. Thus, inductive training involves the use of reward (encouraging desirable behaviour by administering pleasant stimuli) and omission (discouraging undesirable behaviour by withholding or withdrawing pleasant stimuli).

### *Compulsive training*

**Compulsion** is a word that refers to forcing or coercing people or animals to do things. In dog training, the terms “correction” and physical compulsion are equivalent. For example, a dog can be forced to stay inside a kennel when the gate is open by shutting the gate sharply on its nose when it tries to walk out (punishment). Or, a dog can be forced to get down off a table by poking it roughly in the ribs until it jumps down to escape the poking (negative reinforcement). In each case, a dog trainer would commonly speak of “correcting” the dog. In compulsive dog training, the handler relies on unpleasant events to obtain desired behaviour from the dog. Thus, compulsive training involves the use of negative reinforcement (encouraging desirable behaviour by withdrawing or withholding unpleasant stimuli) and punishment (discouraging undesirable behaviour by administering unpleasant stimuli). Although the training of working dogs often involves the use of some compulsive methods, it is important to understand that:

1. Compulsive methods are effective and humane only under certain circumstances, specifically when the dog already understands the desired response and how to avoid compulsion;
2. Excessive reliance on compulsion will damage the dog’s rapport with the handler and decrease motivation for work;
3. Compulsion may stimulate defensive and aggressive responses in the dog, and can in many circumstances be counterproductive and even dangerous for the handler; and
4. Some phases of working dog training, most especially when training detection, are to an extent incompatible with compulsive techniques.

**Inductive versus compulsive training.** Inductive and compulsive training are complementary methods. Inductive methods are normally best for teaching the dog to understand commands and to enjoy working. Compulsive methods are often best for ensuring that the dog executes a commanded skill (especially obedience skills) reliably in any circumstance. Some compulsion is normally necessary in working dog training, especially in bitework and obedience. However, inductive methods are to be preferred whenever practical. In particular, inductive methods are normally better than

compulsive methods for the initial teaching of skills. In fact, the use of compulsive techniques for initial teaching can be counterproductive.

For example, to an untrained dog a command (e.g. “Sit!”) means nothing. Therefore, if the handler gives the command “Sit!” and then administers a strong collar correction in the attempt to force the dog to sit (a classical compulsive method for teaching the sit), the dog will have no idea that it can avoid further unpleasantness by sitting. It may instead attempt to defend itself or, more commonly, seek to avoid the handler. More than anything else, such a method is a perfectly designed classical conditioning procedure that conditions fear and/or aggression to the command “Sit!” by pairing the command closely together in time with physical discomfort. However, if the dog is first taught to understand and respond to the sit command using inductive methods, then compulsion can be used constructively to hasten the dog’s sit or to teach it to sit even in distracting circumstances. Thus, the proper role of inductive training is to teach the dog an understanding of skills, while the proper role of compulsive training is to enforce the performance of these skills, if necessary.

Another important application for inductive techniques is during the early stages of handling any dog, even a well-trained dog. The optimal way for a handler to build rapport and a good working relationship with a new dog is to perform inductive training exercises with the animal (such as food-rewarded obedience), even if the dog already knows these exercises.

When training detection dogs, the use of compulsive techniques must be minimised. Attempts to force dogs to search for long periods of time are normally unsuccessful. The detector dog should respond to cues like the command “Seek!” with arousal, excitement, and desire for a reward. Detector dog search behaviour is essentially a voluntary effort, with a reward as its objective.

The detector dog trainer must also be careful not to link compulsion with any stimuli or procedures that will commonly be part of detection scenarios, because these stimuli and procedures could take on secondary punishing properties; for example, if harsh corrections are used to teach the dog to sit, and subsequently the sit is trained as the dog’s final indication response in substance detection. Similarly, punishing a dog for being distracted by food in the course of a search could turn food into a strong secondary punisher, and to the extent that search problems often contain edible items, the dog’s work will be inhibited by anxiety and fear triggered by food odours.

### *Application of inductive training*

In inductive training, the handler employs gentle means to persuade a dog to perform some target behaviour and then reinforces this behaviour. In the event that the dog does not execute the desired behaviour, or executes it incorrectly, the handler omits reinforcement. In the classical example, the handler teaches a dog to sit by drawing the dog’s attention to a piece of food in the hand. Once the dog places its muzzle in contact with the handler’s fist in the attempt to take the food, the handler then slowly raises the hand and moves it slightly backwards towards the dog’s tail, simultaneously giving the command “Sit!”. In following the movement with its head, the dog is very likely to sit. The handler then opens the hand to feed the dog and gives praise. If the dog fails to sit, the handler withholds reinforcement and praise and continues attempting to encourage the sit. In such a stress-free setting, a dog can learn very rapidly to sit on command, it enjoys the work, and it develops affection and trust for

the handler. The stimuli and events during the sit exercise all become secondary reinforcers. Similar methods can be used for teaching almost all obedience exercises.

Once basic skills have been taught to the dog in this inductive fashion, then moderate and humane compulsive techniques can be applied to “polish” the skills without fundamentally changing the dog’s basic liking for its work.

### *Successive approximation and shaping*

Successive approximation is an inductive training procedure in which animals are taught new behaviours by rewarding responses that are progressively more and more like the desired target response. For instance, to teach a dog to sit through successive approximation, a handler gives the “Sit!” command, and then waits until a small approximation of a sit is seen, such as flexing of the hind legs, and then reinforces this movement. Once the dog is flexing its legs readily for reinforcement, then the handler should withhold reinforcement until the animal exhibits a flexing that is slightly greater than before and then rewards this behaviour, and so on. The entire process of extracting a trained response through successive approximation is called *behaviour shaping*. Successive approximation and shaping are of central importance in the training of animals such as killer whales and sea lions, but they play comparatively little role in dog training, for the simple reason that a good dog trainer can usually think of a way to get the dog to offer the complete behaviour, and then reward *that*. For example, teaching a dog to sit using a piece of food held in the hand (described above).

However, particularly in the case of very complex or difficult behaviours, or behaviours that the dog resists learning, a handler may reinforce the dog for a good “effort” in the direction of the desired target behaviour. For example, in the course of an initial sit-training session, if the dog only crouches without completing the sit, but is working hard to please the handler and obtain the food, it is usually wiser to reward the animal for the partial sit, encouraging the dog to continue trying to learn the lesson.

## Reward schedules

A reward schedule is a rule that dictates how often a dog receives positive reinforcement when it correctly executes a skill. For example, apply the rule that the dog will be rewarded every time it downs promptly on command. Alternatively, the dog might be rewarded every third time it downs promptly on command. Such schedules produce different effects and are appropriate at different stages of training. There are six types of reward schedule.

1. **Extinction schedule.** An extinction schedule is used to eradicate or extinguish a learned behaviour. To extinguish an instrumental response the behaviour is allowed to occur repeatedly, without being rewarded. The behaviour will gradually decrease in strength and frequency until it disappears. Thus, to extinguish an undesirable behaviour (e.g. jumping-up), it is often sufficient to identify whatever is rewarding the behaviour (usually a reaction given by the handler when the dog jumps up) and then make sure that this reward never follows the problem behaviour. This process is called “putting jumping-up on an extinction schedule”. Some behaviours are “intrinsically” reinforcing — just doing them is rewarding for the dog. If a behaviour is intrinsically reinforcing, it will not extinguish even though we put it on an extinction

schedule. Thus, if an anxious dog releases tension by barking in its kennel, it may not ever stop barking, even if the handler never goes to it when it is barking.

**2. Continuous reward schedule (CRS).** A reward is given immediately every time the dog makes a correct (or sometimes a near-correct) response. Assisting the dog to assume the desired position or behaviour is permissible (i.e. in the case of the sit, gentle pressure on the rump to encourage the animal to sit), but it is preferable to encourage the dog into the behaviour by baiting it with food or some similar technique. Inducing the animal to perform the desired behaviour independently and then rewarding the behaviour will produce more rapid learning than “pushing” the animal into position and then rewarding it for allowing this to happen. CRS is the most effective reinforcement schedule for the initial training of a skill.

**3. Fixed ratio reward schedule (FRRS).** A reward is given to the dog after it makes two or more correct responses. It is most useful to think in terms of ratio schedules of reinforcement when teaching behaviours that are “episodic” like barks and scratches. At the beginning of a FRRS, every second response is rewarded. When the dog consistently makes two responses to obtain a reward, then the handler requires three responses. By increasing the number of responses, one at a time, and training the dog to perform at each level with 100 per cent proficiency, a high FRRS can be achieved. For example, a fixed ratio reward schedule might be used to train a dog to bark or scratch repeatedly at a door to indicate the presence of a target odour inside a room. During initial training, the handler will open the door and give the reward after one bark or scratch, then two barks or scratches will be required, then three, and so on.

**4. Variable ratio reward schedule (VRRS).** To use a VRRS, the handler selects a range of responses (e.g. 5 to 10 correct responses) and rewards the dog on a random basis within this range. For example, say the dog has already learned to bark 15 times in order to obtain a reward on a FRRS. In a new training procedure, the reward appears anywhere between 5 and 10 barks, so that the dog never knows whether it will have to bark 5, 6, 7, 8, 9, or 10 times for the reward.

**5. Fixed interval reward schedule (FIRS).** Reinforcement is given to the dog after it responds to a command for a given fixed period of time. This procedure is used when teaching behaviours that are “continuous”, such as a sit- or down-stay, or walk-at-heel. In initial training, the dog is required to stay for only a few seconds. Then short periods of time (e.g. 5 seconds) are added to the interval, while requiring the dog to attain 100 per cent proficiency at each interval. For heeling, a trainer initially rewards the dog for just a few moments of correct heeling. With time and practice the handler gradually extends the period of time that the dog must walk at heel.

Gradual extension of the period of time a dog works for the reward is crucial in detection training. Initially, the trainer arranges a search problem for a novice dog so that it can easily find the target odour and obtain the reward in a short time, say less than 30 seconds. An advanced dog is required to work for 5 or 10 minutes or more, prior to finding the target odour. The emphasis in these exercises is not to force the dog to work for longer and longer periods of time prior to finding the target. Instead, the aim is to help the dog to exhibit highly concentrated and focused search behaviour for increasing periods.

**6. Variable interval reward schedule (VIRS).** To use a VIRS, the handler selects a time range (e.g. 1 to 2 minutes) and rewards the dog on a random basis within this time



period. For example, if the dog has already learned to hold a down-stay for 3 minutes on a FIRS, then the reward is given somewhere between 1 and 2 minutes on a random basis. The dog will learn that it must hold the down for at least 1 minute and perhaps for up to 2 minutes in order to obtain the reward.

### *Application of reward schedules*

Normally, in dog training it is not necessary or even desirable to consciously apply first fixed and then variable schedules of reward. It is usually sufficient to follow the following general rules:

- When teaching a dog to give an episodic response (e.g. barking), the reward is initially given every time it barks (CRS), then gradually the reward is provided after longer sequences of barking (FRRS). If the dog shows hesitation or confusion, the number of required barks is decreased until the animal regains proficiency, and then the number is increased again. Immediately the dog understands the idea of giving voice repeatedly (barking perhaps five or six times), then a random number of barks in the range of three to five is rewarded (VRRS). Finally, the maximum number of times that the dog must bark for reward is progressively increased. The required number of barks for reward must not be predictable, and the dog should occasionally be rewarded for just two or three barks.
- When teaching a dog to perform a continuous response (e.g. searching for target odour), performance is established by rewarding it consistently after a very short period of time. Then the period of search time is slowly extended (FIRS). The duration requirement should be decreased if the dog's performance deteriorates. Once the dog searches intensively for a meaningful period of time (say 20 or 30 seconds), then it is rewarded randomly for searches of various durations less than 30 seconds. Finally, the maximum duration of searches is gradually increased, although the dog still searches for randomly varying periods of time prior to reward.

### *Advantages of variable reward schedules*

Using fixed reward schedules the dog can learn to bark many times in succession or stay for several minutes. However, fixed ratio schedules of reinforcement (FRRS and FIRS) with high requirements (i.e. many, many barks or very long search intervals) do not produce a steady level of effort and motivation. Animals under high fixed reward schedules tend to “scale” their efforts. For example, a dog required to bark many times for a reward tends to bark lazily and intermittently at first (or even take a long rest after each reward), and then to increase its level of effort as it nears the required number of barks that will bring reward. Similarly, a dog consistently required to search for very long periods of time prior to earning a reward will tend to search half-heartedly until its “internal clock” tells it that a reward is nearly due. To avoid these effects, the trainer should not apply fixed schedules of reinforcement for too long. That is, as soon as the dog has learned to bark several times for reward, or to search steadily and with a high level of intensity for 20 or 30 seconds, then the trainer should switch to random schedules. In the case of detection, longer search periods must still be accompanied by occasional short reward intervals. Otherwise the dog will invest comparatively little effort during the first few minutes of a search problem, only increasing its focus (and accuracy) once it is well into the problem.

One advantage of random schedules of reinforcement is the production of uninterrupted and high-intensity responding from the very start of an exercise.

Variable reward schedules also encourage persistence in the face of extinction. That is, variable schedules teach the dog to be persistent and stubborn in trying to obtain its reward through instrumental behaviour, even when the reward rate is low. Many studies have shown that variable reward schedules produce more persistent conditioned behaviour than fixed schedules. A simple explanation of the variable reinforcement phenomenon is this: when the dog never knows how many times (or how long) it will be required to perform before being rewarded, it “loses track” of how many or how long and concentrates on performing persistently, convinced that if it tries hard enough it will eventually get the reward. This is highly desirable behaviour in a detector dog.

## Application of compulsive training

Just as it is important to understand certain basic principles (such as reward schedules) in order to perform effective inductive training, it is also important to understand certain basic principles in order to use compulsive training effectively.

### *Use of physical punishment*

Punishment is used to teach a dog not to do something. For example, a dog can be punished for breaking the sit-stay by administering a sharp jerk on the choke collar at the instant that the animal lifts its hindquarters from the ground. The aim is not to train the dog to do nothing, but encourage it to do *something else*, such as maintain the sit. There are four major principles the trainer must understand in order to use physical punishment effectively and humanely:

- First, the dog must have the alternative response in its *behavioural repertoire*. That is, the animal must “know how to” perform the alternative behaviour, and be in a state in which it can do so. For example, if a dog is breaking the down-stay because it is frightened of a jet engine, the dog’s fear may render it unable to avoid punishment. If a trainer physically punishes a frightened dog for not staying, the punishment is likely to make the dog even more afraid and less capable of staying. This is neither humane nor effective dog training.
- Second, physical punishment should be administered at an intensity that is meaningful to that dog (but still humane and defensible) and sufficient to cause it to change its behaviour immediately. Dogs adapt quickly to physical punishment and can learn in a short period of time to endure very uncomfortable events without altering their behaviour. If a very soft correction is used, and then gradually increased, especially very excited dogs intent on working their way to a reward may adjust to the punishment and ignore it. This procedure can unintentionally create a “monster”, a dog that can absorb excessive amounts of physical abuse without ceasing to exhibit the problem behaviour.
- Third, physical punishment should not be continued if it is not working. For any number of reasons, the dog may be incapable of the alternative behaviour. For example, a history of bad training may have rendered humane and reasonable levels of physical punishment ineffective. It is inexcusable to continue to physically punish a dog without specific and achievable training objectives in mind. In addition, some working breeds (e.g. German shepherds, Malinois)

readily exhibit handler-aggression when subjected to painful corrections that they do not know how to avoid.

- Fourth, emotionality on the trainer's part compromises the use of physical punishment. That is, an angry or frustrated handler may lose the technical ability to control the timing and the intensity of inputs to the dog, and make mistakes as a consequence. Revenge or temper have absolutely no place in working dog training.

### *Use of negative reinforcement*

Negative reinforcement involves rewarding behaviour by withholding compulsion. The classic example in working dog training is the "out", in which the dog releases an agitator or a reward object (e.g. a rubber ball) on command. Although a handler uses any available positive reinforcement to reward the dog for releasing cleanly (e.g. praise, immediate re-bite, etc.), the "out" is normally taught and maintained principally through the administration of negative reinforcement. Thus, if the dog releases cleanly on command, it is NOT corrected with a jerk on the choke collar. All four of the principles stated above with reference to physical punishment also apply to negative reinforcement. In addition, the following terms and definitions should be understood.

**Escape training.** Escape is an initial stage of negative reinforcement training during which the dog learns to end or stop a state of discomfort by executing some target behaviour. For example, during the escape stage of training, the command "Out!" is meaningless. The dog does not yet understand that "Out!" means a collar correction will occur if it does not release. Therefore, on the first trial, when the handler gives the "Out!" command the dog will probably continue biting. The handler then applies a collar correction until the dog releases the bite, praising the dog once it has released. The next trial or two will proceed in much the same way, but the dog *is* learning. During this stage the dog learns to expect the correction when it hears the command "Out!", and it also learns to "turn off" or terminate the correction by releasing the bite. This escape learning is very important. A dog that does not know precisely how it can "turn off" compulsion will be confused and stressed by corrections, and may engage in inappropriate behaviours to try and terminate discomfort, such as avoiding or biting the handler.

If a complex response like walking at heel or recalling to heel is trained using negative reinforcement, there must necessarily be a stage during which the handler teaches the dog to terminate collar corrections by placing itself at heel. If the animal does not know which behavioural response will terminate compulsion, then collar corrections will only make it move more and more strongly away from the handler. It is therefore essential to use reward-based learning to patiently teach the dog skills *before applying escape and negative reinforcement techniques* — to make sure that the dog knows how to perform the desired behaviours on command. The dog will then be ready to learn quickly how to terminate compulsion by executing a commanded behaviour with minimal stress or confusion. Quick learning under compulsion will minimise the amount and intensity of physical force required for training, and help to render work a pleasure for both handler and dog.

**Avoidance training.** Avoidance is the next stage of negative reinforcement training during which the dog learns that in addition to terminating compulsion by executing the target behaviour, it can completely avoid compulsion. In the example of the out, if the dog releases the bite quickly on command, the collar correction will never occur.



When avoidance is completely and cleanly taught, every time the dog releases on command it is rewarded by the absence of the correction.

**Criterion avoidance.** The end goal of negative reinforcement training is to secure a correct response to the command every time, without the need for compulsion. In working dog training, this goal has the additional dimension that the handler intends to eventually discard the means of compulsion (e.g. choke collar and leash) completely. For example, a fully-trained dog should release a ball cleanly on command when it is not wearing a choke collar or leash, and when the handler is 3 or 4 metres away. The handler will therefore not discard the means of compulsion until the dog has achieved a good avoidance *criterion*, such as consistent response to command over at least four or five training sessions. During these error-free training sessions the handler will be ready to correct the dog instantly, with all necessary equipment in place. If the response is not consistently offered without the need for compulsion, then the dog must continue to practice with the handler standing by ready to enforce obedience, until criterion avoidance is obtained and extensively practiced.

**Misuse of escape training.** Repeated and prolonged physical correction of a dog to force it to carry out exercises is a sure sign that positive learning is not taking place. For example, if the choke collar is used ten times in a row to force the dog to release the bite when the “Out!” command is given, then there is no progress and the dog will never learn to out this way. The escape phase of learning in any given exercise should be extremely brief — between one and, at most, four repetitions of the exercise with corrections applied. This is quite enough for the dog to learn how to “turn off” the correction. Then it should be moved smoothly and efficiently into avoidance training, where it releases on command (rather than when the correction is applied) in order to avoid the correction.

**Supporting negative reinforcement with positive reinforcement.** Although behaviour learned through negative reinforcement training can be very durable and reliable, negative reinforcement should be followed by positive reinforcement whenever possible. The trainer can give the dog pleasant rewards to work for *in addition to* the reward of not being corrected. For instance, after a clean, fast out from the ball, the dog is praised and allowed to re-bite the ball and play with it.

### Relationship between classical conditioning and instrumental conditioning

Very little working dog training involves the deliberate creation of classically-conditioned associations, as in the example of the “No!” command above. Most of the “action” in dog training has to do with the use of reinforcers and punishers to produce instrumental conditioning. However, classical conditioning processes are relevant because they are in the background of most training experiences for the dog.

Classically-conditioned associations contribute to training in countless ways. For example, if a handler gives a detection dog a preparation cue (e.g. “Ready to work? Ready to work?”) prior to taking the animal into a search area and giving the search command, the dog will associate this cue with the opportunity to search for target odour and the excitement of receiving a ball. The dog will soon begin to exhibit excitement and arousal responses to the preparation cue, encouraging enthusiastic search behaviour. In this example of classical conditioning, the preparation cue is the CS, the opportunity to play with a ball is the US, and arousal responses are the CR. This classical stimulus-stimulus association (between preparation cue CS and ball

reward US) lies in the background of the instrumental response-consequence association (between search/detection behaviour and ball reward) used to teach the dog to search for target odour. Here, the ball serves as both the instrumental reward for a correct sit, and as a US that classically conditions stimuli (such as the preparation cue) associated with training.

However, classically-conditioned associations in the background of instrumental procedures may also hinder learning. For example, if a dog sits too slowly in response to command, the handler may decide to hasten the sit by applying physical force. The handler gives the command “Sit!”, followed by a strong jerk upwards on the choke chain when no sit response is given. The intention of demonstrating the unpleasant consequence of sitting slowly actually constructs a very effective classical conditioning trial — “Sit!” is immediately followed by a sharp jerk on the collar. Soon “Sit!” develops the power to trigger responses appropriate to a sharp collar correction. Such responses can range from pain-elicited aggression and biting, to avoidance and cowering. More commonly, they involve anxiety and a reflexive stiffening of the body’s muscles to defend against the sharp jerk on the collar. The physical stiffening hinders the dog’s ability to sit quickly, with the result that it receives yet another jerk on the neck, which makes it even more anxious and stiff when it hears “Sit!”, and so on. In this example, the classically-conditioned *stimulus-stimulus association* between “Sit!” (CS) and a collar correction (US) is superimposed on the instrumental *response-consequence association* (a quick sit will result in no collar correction) that the handler has in mind. Thus the “Sit!” command will begin to elicit involuntary responses from the dog related to the discomfort of a collar correction, and these involuntary responses will interfere with the dog’s ability to sit quickly and smoothly on command.

## Generalisation of classical and instrumental conditioning

Generalisation is a process in which behaviour that is learned in response to one stimulus is expressed to some degree as a response to another stimulus. Generalisation takes place with both classically-conditioned and instrumentally-conditioned behaviours, and the more similarity there is between two cues or situations, the more generalisation there will be. Two examples of undesirable generalisation: a dog that has learned a strong startle response to the “No!” command may also startle when the handler says “Yo!” loudly to a friend; a dog that has learned to sit in response to one explosive odour, such as ammonia dynamite, may also sit in response to a similar non-explosive odour, such as ammonia-based house-cleaning liquids. Generalisation can also be useful, for example if a dog trained to sit in response to the odour from an explosive device made with one brand of smokeless gunpowder also sits in response to an explosive device made with a different brand of gunpowder.

## Generalisation of behaviour learned in one context to another context

Trained behaviours are not just controlled by CSs (classical conditioning) and cues/commands (instrumental conditioning). They are also controlled by context, a word psychologists use to label all other environmental stimuli present in the conditioning

situation. Context participates in learning, and generalisation from one context to another is rarely perfect. For example, if it is obedience-trained only in the context of an isolated training field out in the country, a dog will probably perform poorly the first time it is “run through” an obedience routine in a busy city park with people crowded around. Likewise, a dog that learns search and detection behaviour in a warehouse may also perform when it is taken to an office building, but its performance is liable to be poor until it gains experience in the new context. The best way to ensure that trained behaviour is independent of context is to train in as many different places and situations as possible, once the initial learning phase has been completed.

## Transfer of learning

Transfer of learning takes place when one learned skill or command affects learning of another skill or command. Transfer can be positive (favourable) or negative (unfavourable).

In negative transfer of learning, one learned response interferes with the attempt to train another. For example, if a dog has previously been encouraged to claw and scratch and bite through a barrier in order to reach a ball (a technique commonly used by trainers to build “drive”), this response may transfer to explosives detection training, making the dog more likely to claw and scratch at the source of a target odour.

In positive transfer of learning, one learned response helps the dog to learn another. For example, learning to sit in response to the “Sit!” command during obedience training transfers positively to detection training by helping the dog to learn to sit in response to odour.

A skilled handler minimises opportunity for negative transfer of training to take place, and maximises opportunity for positive transfer of learning to occur. Efficient dog training can be viewed as a sequential, cumulative process in which the learning of one skill assists the learning of the next skill in the sequence.

## Chapter 2

### Case studies on training mine detection dogs

# Part 1

## Socialising puppies for demining

*Johan van Wyk and André Le Roux*



### Introduction

As people who are rearing our own potential demining dogs, we have, through time and practical experience, created what we believe is a unique way of rearing a working dog in a kennel environment.

Through rearing and working with different breeds, we must also point out that each breed is different to another, which seems logical as each breed was intentionally bred for a specific purpose. In practice, each breed is so different that there is no choice but to treat them all differently.

Even when working with one breed, no set system of training can be applied because no two puppies or dogs are the same. What you do and how you do it will be applied

differently to each dog. It all depends on how well you know them and if you have the natural ability to “read” their behaviour.

Negative experiences during the socialising period will have an effect on mutual trust between the animal and the other animals, and with humans. Young animals which have a variety of positive influences during this time are better equipped than animals that grow up in a closed environment. Lack of socialisation may lead to behavioural problems such as aggression or fear.



## Choice of parents

What are the most important qualities we look for in our demining dogs?



The ideal parents for our requirements are those which are not only still acceptable in the show ring but also carry our desired genetically-inherited working traits.

In their physical appearance we look for:

- Good colour and pigmentation;
- Ears that stand erect and are standard size for the breed;
- Correct size according to breed standards; and
- They must be hip dysplasia free.

In their temperament we look for dogs which are:

- Highly adaptable;
- Courageous;
- Outgoing;
- Stable;
- Not nervous;
- Have good intra-species relationships;
- Have excessive drive, hunting and herding instinct.



## Care of the dam

The bitch is moved to the whelping den two weeks before giving birth. She is still groomed and taken for daily walks. To ensure a healthy pregnancy and puppies, the bitch is given a balanced diet to help her recover from the birth.

The whelping den is a large grass camp which contains a kennel with underfloor heating.



## The new arrivals



Clearly, the mother plays an important part in the lives of the pups and the bonding between them is also very important. It is also important that the puppies pass successfully through the imprinting stage of their development: if a puppy does not learn certain behaviours at this stage, its adult life is adversely influenced.

We do not believe it is our place, or right, to constantly interfere in a perfectly natural and normal part of life. We prefer to keep our distance but do check that all is going well with the mother and her new pups. We keep a constant eye on possible complications with the dam's milk supply and ensure she has enough to keep all the puppies satisfied.



## The socialisation process for the first 16 weeks

### *Neonatal period (0–2 weeks)*

This period is about getting nourishment from the mother. A puppy this age can only move within a small radius. The puppies crawl and come into contact with the mother's breast and begin sucking movements. Their eyes are closed and so are their ears.

During this time we believe in mildly stressing the puppies for the following reasons:

- It will enable them to cope better with stress;
- They will be more outgoing;
- It enables them to learn faster;
- It is believed to increase the brain size.

The stress is applied in the following manner:

*First week:*

Day 1: Each puppy is held down firmly on one side for 10 to 20 seconds.

Day 2: Each puppy is held down firmly on the other side for the same length of time.

Days 3-7: Each puppy is held up in the air, upside down, turned in a circle. Puppies must be weighed daily on a cool surface.



*Second week:*

The stress is intensified by squeezing the ear flap and the webbing between the toes. Each puppy is placed on a wax wrap just taken out of the fridge.

*Transition period (third week)*



The puppies can move around more and their eyes will open. They can eat solid food and will also start growling over a bone and begin play-fighting with their littermates. They will also start walking.



In this week we introduce novel stimuli to the whelping area — by providing them with plastic milk bottles, safe toys, knotted strips of cloth, cardboard boxes, balls, feathers, etc. We also introduce audio stimuli in the form of a radio playing at a low volume, increasing in volume over time. We still handle the puppies daily, talking to them and giving them individual attention.



### *Socialisation (3–6 weeks)*

The puppies now begin to make more varied sounds and begin to respond to the sight or sound of people and animals. They can lap up water or milk and begin to assume the adult form of locomotion and chewing. They also begin to follow each other around.



We still give individual attention and auditory stimuli. For short periods they are taken out of the den into new buildings and areas. They are exposed to new sounds, noises and moving items. They are provided with new objects, e.g. empty plastic bags, empty boxes, dark rooms, moving chairs on wheels and toys that they can bite and retrieve.

At this stage we also start to feed them and the feeding times are combined with gunshots from a distance of 100-200 metres. They are also exposed to idling cars, small fans and strange people. We do not believe in carrying the puppies around: it is of vital importance that their curiosity leads them to investigate their new surroundings. This is still a gradual process which cannot be rushed. The puppies must progress at their own pace and must never be forced. The mother can also go with them on these socialising trips to give the puppies more confidence.

This period may sound very easy, but it is an extremely important one. The handler of the puppies must be aware of all normal behaviour patterns of this age and must react accordingly. The puppies are taken regularly for car rides of short distances. We introduce them to our office, where they experience a great variety of new and different articles. We make so many changes that every time they think they know what to expect, we will surprise them by adding something new and moving the not-so-new items they are already accustomed to. We encourage them to get into air transport crates similar to those they will be transported in when older.



We bring them into frequent contact with people they do not know. They are introduced to machines like lawnmowers, generators, fans, vacuum cleaners, etc. This age is extremely versatile. It is impossible to exhaust your resources in finding new challenges for them. Everything up to now has been done in a puppy group. In some cases the mother will go along to give the puppies more confidence.

### *Socialisation (6–8 weeks)*

A puppy at this age has already had its first introduction to people. It should never feel dominated by us and will not be socialised in a litter anymore. The mother will already have started weaning the puppies.

Our puppies are leash trained at this age and will walk alone with their handler on a leash. The socialising will also be done on a leash. No punishment is inflicted on the puppies.

They are now used to the gunshots and have learned that it has never caused them physical pain. We continue with all our socialising processes. When they are eight weeks old, they are separated from their mother, whom we move out of the camp. Situations which may evoke intense and stressful reactions are avoided but are sometimes necessary. A puppy should never be praised for being afraid, rather ignored.



We continue introducing them to new people in new places. They are encouraged to negotiate new obstacles like boulders, trees and rocky areas where loose stones may slide under them, sand pits, dunes, gravelled surfaces, water and small rivers. Other obstacles include steps made from different materials, e.g., grid or bricks. The list of what we try to expose them to is endless.



The relationship formed with the handler is of vital importance. If done incorrectly it will become progressively more difficult for the pup to adapt to the changes it will have to encounter. From a young age we place great emphasis on encouraging the puppies to retrieve objects for us, indirectly increasing prey-drive. And at this stage the nature of the object is irrelevant. We make a great fuss if something is retrieved for us, so that the pup eventually does this automatically if it is with us.

The pup has already learned that, to be fussed over, it must have something in its mouth. This is very important for further training. Obstacles can still be done in a small group.

### *Socialisation (8–12 weeks)*

We still continue with the daily routine of socialising sessions. This includes going to shopping centres, train stations, city centres, etc. These sessions will increase in time and intensity. The puppies also have retrieving sessions during which they are taught to use their noses.



When the puppies are eight weeks old, we wean them completely. They have already learned important things from their mother and are now ready to be without her. During the day, once returned from their socialising trips, we prefer to leave them in an obstacle course. This is a camp that consists of many obstacles that the puppies learn to overcome through trial and error.

### *Socialisation (12–13 weeks)*

The puppies start sleeping in pairs in kennels overnight. Throughout the day they will still be in camps. Socialising continues as normal. We like to take them to city centres where there are lots of people, shops, cars, buses, trucks, etc.



Aggression training can be done at the kennels to give the dogs confidence in their kennels. Gunshots are still part of the daily routine. By this age shooting can be done from 5-10 metres away. Fireworks, especially crackers, are also used for this exercise.



### *Socialisation (13–14 weeks)*



The puppies are now separated from their littermates. They also now sleep alone and are worked individually. They go for long daily trips of three to four hours. They are also taken to shopping centres, train stations, bus and truck depots.



If necessary, aggression training is done away from the kennel to give the dog more confidence. Transportation of the dogs to the socialising places is done with different vehicles (if available) e.g. trucks, pick-ups and dog trailers.

Weekly evaluations monitor improvements in their play-drive, socialising, confidence and character.



### *Socialisation (14–16 weeks)*

Aggression sessions continue, but special care is taken not to increase their aggression levels above those that will be expected from them in their future working conditions.

These sessions are very positive and are based on play-drive. They are conducted only by experienced puppy assailants who know how to build confidence without eliciting fear in the puppy. Even though they become more confident, they are still treated with great care as they are still in a sensitive period.

Socialising also continues.

## Programme for 4-8 months

We continue our daily routine of socialising. At this age, puppies will cut their permanent teeth and this will affect their ability to retrieve items and this must be taken into consideration.

Young dogs have been taken to the advanced obstacle course. Every second day they are taken for three to four hours to shopping centres, train stations, schools, etc.



We continue with aggression training and gunshots.

By now the socialising and aggression sessions have become more intense, which helps to strengthen the dog's character.

## Programme for 8-12 months

All dogs start obedience training at eight months.

Socialising continues with three- to four-hour trips to different places. They then begin their formal demining course. We believe that a dog of 12 months of age is mature and confident enough to begin this formal demining training.





## Chapter 2

# Case studies on training mine detection dogs

## Part 2

# The REST concept

*Rune Fjellanger*

### Introduction

Detection methods that make use of vapour from explosive devices, collected via a filter, have seen limited acceptance as a method of detecting mines/unexploded ordnance (UXO). Only a few organisations currently use such a process — even though it has proved to be extremely cost-effective and offers several safety advantages relative to more typical detection techniques. The detection system is known as Remote Explosive Scent Tracing (REST). The REST system can briefly be described as a process of collecting target substances (usually traces of explosive vapour) from the surface of a mine/UXO suspected area, using filters that are subsequently analysed by specially trained sniffer dogs.

Target substances from explosives can be collected by suction of air and dust particles from the ground surface using a portable vacuum pump with filters, placed either in a vehicle or carried as a backpack by a person walking. The filters are made of coiled polyvinyl chloride (PVC) netting. The air samples are collected over sections of 100-300 metres. The operator follows in the wheel tracks of mine-proof vehicles and collects samples from the ground area on each side, within the reach of the sampling mechanism. The filters are subsequently sent for analysis by specially trained sniffer dogs, and these will indicate whether target substances from mines/UXO exist.

The REST method was developed by the South African Government at the end of the 1980s, in the hands of Mechem Consultants, a division of Denel (Pty) Ltd. The method was first referred to as MEDDS (Mechem Explosives and Drug Detection System). It has subsequently also been called EVD (Explosives Vapour Detection) by Norwegian People's Aid (NPA)-Angola, and Checkmate in the USA. The primary purpose of this method was to detect drugs, explosives and weapons at border crossing checkpoints. The system was used at the many checkpoints in South Africa at the borders with Lesotho and Swaziland, but also at the main border crossings to Botswana, Mozambique, and Zimbabwe. Experience has shown that the system has the capacity to check a significant number of vehicles, train carriages and other cargo in a short time and requires few personnel.



Mechem Consultants also recognised the potential of using REST (=MEDDS) to detect buried explosive devices. All explosives emanate vapour; this applies also to mines made of plastic and metal. In 1991, Mechem became involved in commercial demining and gradually established integrated advances in this type of operation via the use of mechanical, technical and manual techniques. The manual mechanism involved use of dogs, and here the focus eventually came round to detection with the REST method. The first time REST was used to carry out a complete survey contract was at the Cahorra Bassa Power Transmission Line. The contract was for Hydroelectricidade de Cahorra Bassa, Mozambique, in 1994. This was the first time contracts for demining and survey were carried out by detecting and analysing vapours from the area to be surveyed. The results showed that only 10 per cent of the total area to be surveyed had to be cleared of mines/UXO.

On 25 June 2000, the Norsk Kompetansesenter for Spesialsøkshund AS (NOKSH AS) entered into a contract with GICHD for the execution of sub-study IV–Vapour Sampling and Analysis (MEDDS/EVD) as a part of the GICHD MDD programme. Subsequently, sub-study IV was divided into Sub IVA (a review of training programmes for producing REST dogs, and applications of REST), Sub IVB (development of filters) and Sub IVC (the NPA-Angola area reduction project). NOKSH AS is responsible for the completion of Sub IVA, the results of which are presented here.

The word “imprinting” is used frequently in relation to the problem of teaching odour discrimination to dogs. Unfortunately, “imprinting” has several different meanings, including at least two when used by dog trainers, and several more can be found in the biological literature. In order to avoid the ambiguity associated with this word, it is used here as used most commonly by dog trainers working with MDDs. In this context, it means “teaching odour discrimination skills to a dog”. This definition excludes aspects sometimes intended in the use of the word, that involve exposing the dog to odours as a background cue, or teaching the dog to indicate a positive target. To further avoid confusion, we refer to *explosive odour imprinting* when meaning the definition above.

In this report, the REST concept is introduced and an overview is provided of the principles of learning that are relevant to the original training and maintenance training of a REST dog. A series of case studies are presented, the first two being reviews of programmes in South Africa (Mechem) and Angola (NPA), and the third being an experimental training programme undertaken by NOKSH AS. The principles laid out in these sections are integrated into a broader framework for application of the REST concept in the discussion.

### *The REST case studies: collecting information*

Our initial aim was to enter into discussions with central people within organisations with experience of working with REST. NOKSH AS initially contacted Mechem and NPA. A general request was also sent out for material preferably compiled within the individual organisations. The wording of the request was very general and made no specification of actual information to be sent. The material could be printed, written, photographic or on video — all types of information were welcome.

Our next aim was to pay visits to the organisations, so that representatives of NOKSH AS could talk directly with instructors and trainers. The result of our collective request

for general information was practically zero. However, direct contact with representatives of Mechem and NPA was 100 per cent positive. We have visited the organisations and gathered information via interviews and direct observation.

Representatives of NOKSH AS were given the first information regarding REST on a visit to NPA's dog project in Angola in 1998. Later that same year, representatives of NOKSH AS attended a seminar held by Mechem in England regarding the training of dogs for use in REST analysis, making practical use of the system.

Information was also gathered from a number of meetings and conversations with representatives of Mechem, along with a two-week stay at the Mechem training centre in Pretoria, South Africa.

NOKSH AS has, as a part of sub-study 4, also carried out the training of four dogs according to guidelines provided by Mechem (at the seminar in England, 1998). In connection with this training project, a description of the training programme has been compiled along with analyses intended to display positive and negative aspects of the REST system.

### *The REST system in operation*

The following summary is taken from IMAS 09.43 (draft version 7.0) and the REST standards, and the SOPs prepared by NPA-Angola and Mechem.

REST as a system is not a method for demining, but rather a system for eliminating areas of ground suspected to contain mines where no scent or target substances of explosives can be found. From the beginning, the REST system has principally been used to search roads during demining operations (See Chapter 4, Part 1). The system has proven to be very cost-effective as it greatly reduces the areas to be demined, allowing up to 90-95 per cent of the road to be declared safe after REST has been used.

The REST system has less application in areas where there are established, regular minefields. In such areas, all the filters would be contaminated by scent substances from explosives and the dogs would indicate all filters as positive. No useful information is provided, other than that the air samples have been collected from areas with target substances from mines/UXO.

However, if REST is used to chart whether there are potential areas containing mines/UXO and possibly to verify the perimeters of such areas, then the system has significant application. Systematic tests with sufficient documentation are lacking with regard to the use of REST for area clearance, although Mechem in South Africa have performed preliminary tests using REST for area clearance, with good results.

### *Sampling*

Sampling is a common term for procedures used when air samples are collected using vacuum suction and filters. Each air sample is represented by the molecules which remain after a volume of air has passed through the filter. Two sampling procedures are described in this report:

- Procedures for producing a controlled material (filter) for training will be referred to as sampling (sampling for training). Each filter is manufactured to detailed

specifications and therefore has varying concentrations of scent substances, enabling training of dogs in the analysis process. Sampling of filters for training will be described in more detail under the description of training procedures (Mechem, NPA, NOKSH AS).

- Sampling carried out by collecting air samples from genuine minefields will be referred to in this report as scent trapping. Quality assurance of procedures for scent trapping depends on detailed planning and preparations. Scent substances to be trapped and analysed are in very low concentrations. The slightest deviation could prevent proper information (scent substances) from being collected. The smallest error in the performance of the procedures may lead to deviations and thus an unreliable system. If sampling is to have sufficient quality assurance and be carried out in accordance with the individual organisation's SOP, there has to be a close cooperation between the breaching team and the scent trapping team.

### *Breaching*

The breaching team is normally mechanised and makes use of mine-protected vehicles to enter areas that have not been cleared for mines. This support function includes responsibility for vehicles (driver, mechanic), logistics (supplies, marking of sectors, position plotting) and medical personnel. The team also has its own team leader.

The most important tasks for the breaching team are to ensure safe access to the areas to be cleared. When a mine-protected vehicle is used, the team will be safe as long as they remain within the vehicle. Each vehicle shall carry personnel qualified to carry out manual demining in order to secure other personnel who may, for example, have to perform repairs on the vehicle out on the field.

Prior to any sampling procedure, evacuation plans shall always be prepared in the event of accidents. These shall also include evacuation plans in the event that a mine-protected vehicle is irreparably damaged (e.g. by an anti-tank mine). The medical personnel are responsible for preparing these evacuation plans.

Another task for the breaching team is to ensure sufficient supply of equipment for executing a field operation. Demining is often carried out in isolated areas and on roads closed to other vehicles because of the danger of mines. The breaching team shall therefore carry equipment to ensure self-sufficiency over long periods of time, requiring detailed logistics both prior to and during the task to be executed.

#### *A scent trapping team and its tasks*

A scent trapping team is normally made up of five to seven persons, including one person responsible for ensuring that procedures are followed in accordance with the relevant SOP.

Scent trapping can be executed directly from a vehicle, but experience has shown that manual scent trapping is more reliable. A portable suction machine collects samples through a tube from the pump connected to a long tube (1.5-2 metres) with a double-headed filter cartridge on the end, allowing the operator to collect two samples simultaneously. With the long tube, the filters can be moved from side to side over the ground while the operator moves slowly forwards along a secure area. A "secure

area” may be the wheel tracks made by a mine-proof vehicle. Areas may also be secured by other methods.

When a scent trapping team operates behind a mine-proof vehicle, the procedure involves two pairs of personnel: a vacuum pump operator walking in a wheel track, with an assistant behind. The assistant and the operator will change roles regularly. The scent trapper performs the actual trapping of scents by swinging the tube with the filters from side to side as he moves slowly forwards. At set intervals, they stop and the filters are changed by the assistant, who is walking in the same wheel track. The assistant washes the filter heads when the filters are changed, keeps a log of the different filters and their positions, and is also responsible for monitoring movement patterns and walking speed.



*A REST scent trapping team in Angola.*



Scent trapping requires high levels of concentration and involves a very stereotyped movement pattern. It is therefore essential for the scent trappers to take regular breaks and for regular task rotation between the two personnel.

With this method of scent trapping, it is essential to ensure that the entire sector is covered. Any uncovered areas shall not be greater than 25 centimetres x 25 centimetres. Likewise, when scent trapping along two wheel tracks, there shall be an overlap of around 30 centimetres. If each scent trapper covers a total breadth of 2.3 metres and both have an overlap of 30 centimetres, the total breadth covered will be 4 metres.

The filter cartridges shall be held close to the ground during scent trapping to ensure maximum contamination. When air is sucked in close to the ground, dust and soil particles will also be sucked in to the filter. The concentration of strategic scent substances attached to soil particles is one million times higher than in the air directly over the ground (Phelan and Barnett, 2001). However, if the filter is subjected to excessive volumes of dust and soil particles, it will clog and will not be able to collect further trace substances from the ground. The procedure for changing the filter cartridges should therefore be carefully regulated. The maximum height over the ground has been specified as 20 centimetres. The filter cartridges should be passed close to any vegetation. It is generally believed that concentrations of scent substances are higher where there is plant growth.



*Sampling: the operator with an assistant (NPA, Angola).*

The procedure for changing filter cartridges is secured by following a set drill. The filter cartridges are changed at set intervals (each 100-300 metres), established in the individual organisation's SOP. The intervals between the changes of filter cartridge may vary depending on expected density between mines in the area being checked. The main aim is to carry out safe detection of explosive-containing items such as mines/UXO, and this is the determining factor in the establishment of intervals for filter change. Even though more regular changes of filter cartridge imply more work performing the analysis of the filters, a smaller sector for each filter will help save time if any trace substances are detected.

When changing the filter cartridge, the filter, the filter cartridge and the inside of the filter holder must not be touched. The person responsible for this task shall always wear gloves. When a filter has been returned to its original container after scent trapping, a tight-fitting lid is fitted to the container before it is placed in a larger collection box. The filter holder shall be cleaned before a new filter is inserted in order to prevent possible contamination between two filters. Each filter placed in the collection box shall be marked with a detailed log describing position (GPS), date and time. Additional information should include temperature, humidity, wind strength and direction for each change of filter.

When two scent trapping teams are checking a road, they operate with a 25-metre safety margin between them. Each moves forward in their own wheel track behind a mine-protected vehicle and a total of four filter cartridges is collected each interval. Each filter cartridge is stored in a sealed collection box.

### *Analysis of new filter cartridges*

When a stretch of road has been swept and the filter cartridges collected, the filter cartridges are then transported in their respective containers to central units where



specially trained sniffer dogs sniff each filter cartridge. The sniffer dogs have been trained to detect trace substances emanating from mines in the filter cartridge. The filter cartridges are attached to holders or stands (6-12) and these are positioned in a line or circle for the dogs. There may be one or two filter cartridges on each stand. The dogs are trained to move from one stand to the next and sniff each filter cartridge. The dog will indicate a positive find by sitting/lying down if it has detected traces of TNT or other explosives emanating from a mine/UXO. After one dog has sniffed all the filter cartridges once, the order of the filter cartridges is changed by moving the order of the stands. The same dog sniffs the filter cartridges once again. After all filter cartridges have been sniffed twice by the same dog, more dogs are set the same task. When all the filter cartridges have been examined, without any positive indication from any of the dogs, all the filter cartridges are removed and replaced with new ones.

The low concentration of trace substances, together with other possible sources of error linked to the use of dogs, has resulted in a requirement for using a minimum of three dogs in order to eliminate the risk of trace substances. Dogs may make mistakes, even if a filter cartridge contains trace substances from mines. There are many reasons for this. Some dogs are actually not able to detect such low concentrations of scent, others make mistakes because of an incomplete examination or poor examination pattern. Errors may also occur due to the dog handler or because the dog is sick. It is therefore essential that dogs be regularly certified, and “warm-up” procedures are used at the beginning of each day. Reliability of the system is based on the principle that several dogs should not make mistakes at the same time. As with any demining programme, the procedures are designed to give 100 per cent reliability of detection under normal operating conditions due to considerable redundancy in the system. Again, as with any demining programme, it is impossible to completely rule out the possibility that the prevailing conditions or systematic but unrecognised errors may lead to mines remaining undetected.

The ultra-low concentrations of scent substances found in some of the positive filter cartridges is indicative of how sensitive the REST system is to external factors. The slightest error in the set-up of an analysis situation or procedure may lead to unreliable results. It is therefore absolutely essential to have strict (high degree of control) procedures for the set-up and execution of the analysis process. Logistics for both procedures and for the behavioural patterns of the dogs in the analysis situation shall be continuously logged so that results may be analysed and tested where required. The analysis process may be performed in various ways, but the set-up of the actual examination of the filter cartridges depends on the pattern in which the sniffer dogs have been trained. Other significant factors are whether an analysis situation has been set up out on the field or if conditions may be controlled in a laboratory setting. Irrespective of location, certain principles shall be followed:

- The analysis process shall be carried out in a location where humans, dogs or other factors do not disturb the dogs’ “concentration” during investigation.
- The analysis process shall be carried out at an adequate distance from minefields, storage areas for explosives or areas where dust and strong scents may disturb the dog.
- All equipment used shall be cleaned and free from any target substance contamination, and checked where possible.
- The location of the analysis process shall be chosen to provide optimal temperature, wind conditions, humidity, etc., to provide the dog with the best possible conditions for detection.

There shall be sufficient distance between each stand during the analysis process to prevent any cross-contamination between two filter cartridges. Systematic tests are yet to be performed to determine the minimum distance. Furthermore, there has been no research into the significance of this factor for the analysis process.



*Indication of positive filter cartridge on stand (NPA, Angola).*

### ***Handling the filter cartridges and filter containers prior to and during the analysis process***

Dogs trained for analysis in the REST system should be able to detect one or a limited number of strategically selected scent substances. Low concentrations make detection difficult, leading the dog to constantly search for something to make the task easier. When filter cartridges are handled during training and in connection with the analysis process, it is therefore essential that handling has no influence on the dogs' behaviour. Dogs will quickly detect scents from human handling or scents from another dog, especially when such detection gives reinforcement. The use of disposable gloves together with established procedures for the handling of filter cartridges will help to secure the quality of dog training and the analysis process.

Important principles to be considered are:

- When a filter cartridge is placed on a stand, there shall be no human contact with the filter cartridge or any other form of contamination;
- Each filter cartridge shall remain in its container until it is placed on the stand directly prior to the actual analysis;
- Each stand shall be carefully cleaned (decontaminated) before the filter cartridge is placed on the stand and the dog begins its investigation;
- When the various stands are moved between each investigation, the persons moving them shall wear gloves to avoid contact with the stands. No other equipment should be used in this process which could result in contamination;
- Preparation of the filters to be analysed (adding moisture and increasing the temperature) will increase the emanation of molecules from the actual filter and make detection easier for the dog. It is a known fact that optimal temperature and humidity provide the best conditions for the dog, but tests are yet to be carried out on the levels of temperature and humidity to be used.



### Back-up filter

During the scent trapping process, a double-headed filter holder is normally used, providing two essentially identical filter cartridges of trace substances from one area. This provides the potential for a quality control element or secondary analysis of the same area. The extra filter may be used as a control filter in the event of accidents or on request as a control for verification of an area that has already been approved.

A back-up filter cartridge shall be handled in the same way as a primary filter cartridge for analysis. If back-up filter cartridges are not used for analysis straight away, they should be stored for up to five years as a quality control of the area checked.

## Training methodology for vapour analysing dogs: three case studies

Presented here are three case studies of the training and use of REST dogs. The first two case studies describe the methods used by Mechem and NPA to undertake original and maintenance training of dogs for vapour analysis. They include a description of each organisation and the procedures used for analysis of unknown filters.

The third case study is a description and assessment of the training of four dogs by NOKSH AS. This training was designed to be practically identical to the methods used by Mechem, but with several proposed methodological improvements being tested.

All three descriptions of methods are divided into steps. Steps with the same number refer to similar steps in the training programmes, but should not be used to make direct cross-comparisons between programmes. Training for discrimination of a scent substance (TNT vapour strips), and establishment of indication behaviour (sitting) when the scent substance is recognised, have been included under the title “explosive odour imprinting”. Once recognition and indication behaviours are established, further training is described as a series of stages, where again, a numbering system is used to allow cross-comparison between programmes. Direct comparison between Mechem and NOKSH AS can be done using these stages, but the NPA programme is not directly comparable. Differences between the three organisations are detailed.

A description of equipment used is provided in Annex 1. Three examples of sampling, analysis and assessment forms used in REST dog training are provided in Annex 2.

## Case study 1: Mechem

Sources of the following summary are internal unpublished reports and other materials provided by Mechem, notes from verbal interviews with Mechem staff, and direct observation.

Denel (PTY) Ltd is duly incorporated under the Company Laws of the Republic of South Africa. Denel conducts its operating activities through various engineering and manufacturing related divisions on a worldwide basis. Mechem Consultants is a division of Denel (Pty) Ltd.

Mechem has developed significant capacity with regards to personnel, vehicles and other equipment, allowing the organisation to administer and manage demining operations at a very cost-effective level the world over.

Mechem first became actively involved in demining operations on a commercial basis in 1991. Subsequently, the organisation has carried out a number of tasks in many different countries, including projects in Angola, Bosnia and Herzegovina, Croatia, northern Iraq, Kosovo, and Mozambique.

The operations have varied in type. Some projects have involved the entire concept of the “tool box” (i.e. including mechanical clearance, manual clearance and mine dog detection teams), while others have only involved use of mine detection dog teams.

Mechem’s projects in which REST is the main detection system have principally been carried out/are being carried out in Mozambique.

### *Collecting information*

A representative of NOKSH AS visited Mechem in April/May 2001. He spent much of the time observing the dogs being trained in the REST system.

Information was collected via interviews and direct observation. Written observations and video recordings were used as documentation. Written reports were sent to those from whom the information was gathered for comments, corrections and approval, before being incorporated in the final report.

### *General*

Mechem has set up its own training centre in Pretoria, South Africa. Training of dog leaders/instructors and the majority of the training of both field and REST dogs are performed at the centre. Some completion training of the field dogs and dog trainers will be in the country where they are to work (e.g. Northern Iraq). All analysis of filter cartridges is performed at Mechem’s new base in Pretoria, where specially-designed premises have been built for training and analysis.

Training of dogs in the REST system is organised into a 10-15 week training programme. The variation in training time is due to individual differences in the dogs.

### *Selection of dogs*

Mechem does not breed its own dogs but purchases most from South Africa (German shepherd), the Netherlands (Malinois) and the United Kingdom (Labrador retriever, English springer spaniel). It is likely that many dog breeds could be used in the REST system, but the best results have been achieved with the Labrador retriever (the English hunting Labrador). The two features that make this breed particularly suited to the task are: one, it responds easily to reinforcement and, two, it naturally exhibits relatively slow movement. Calm and relaxed dogs such as Labradors are more easily handled during training than more highly-strung dogs, such as springer spaniels. The English springer spaniel and Malinois breeds are good alternatives, but are much more demanding to handle. German shepherds exhibit low levels of intensity (i.e. respond less to reinforcement, making it difficult for the dog to maintain a continuous investigation pattern and sufficient focus on each filter cartridge during analysis).



*Indication of positive filter cartridge on stand (Mechem, South Africa).*

The most important characteristics to look for when selecting dogs for the REST system are:

*High levels of possession/prey drive:* The animal's genetic natural ability to chase, capture and conquer prey items. These items will be used as a primary reinforcement later on in the training. This reinforcement is the driving force for the animal to work rather than (e.g.) "love for the handler".

*Hunting drive:* The dog's genetic natural ability to hunt out prey using its olfactory system. In a strongly driven animal, anticipation of capturing that item causes extreme sniffing behaviour and provides the opportunity to systematically imprint a desired odour. Without the hunting drive, reliable imprinting or extended detection of any odour is not possible.

*Insensitivity to environmental disturbance (i.e. not nervous):* This will minimise the interference of every day disturbances with training. A passing car, loud noise or construction noise will not startle the animal, allowing the training to continue uninterrupted or with minimal adaptation. Additionally the dog is "portable", meaning the animal will travel to new and strange locations and not be influenced by the move or the new surroundings.

### ***The training programme: explosive odour imprinting***

Imprinting is a common term for the procedures used to train the dog to identify a strategically selected odour substance.

Mechem uses pure TNT as the source for odour substance throughout the entire training programme for REST dogs. TNT resides as molecules on small vapour strips (see Annex 1) specially produced for this purpose. When the vapour strips are placed in small, sealed jars, measurements indicate that the concentration of TNT is kept at a relatively constant level, provided that the jar remains sealed and is not exposed to sunlight.

### First step

Dogs selected for the REST training programme start immediately with imprinting. A filter cartridge is opened, the PVC netting is uncoiled and up to eight vapour strips are inserted (positive filter cartridge with high intensity stimulus). The filter cartridge with the vapour strips is placed on a stand inside a small box or cardboard box with a hole on the top. The dog watches as a ball is thrown into the hole in the box, and is allowed to fetch the ball. This is repeated several times, then the hole is reduced so that the dog cannot fetch the ball itself. The trainer then reinforces the dog by throwing a ball near the box while the dog is investigating the hole. The filter cartridge with the vapour strips remains in the centre of the box at all times, so that each time the dog investigates the hole, it will also sniff the filter. Several boxes are then placed in a line, with filter cartridges on stands in each box, but with only one filter cartridge containing the vapour strips. The dog is put on a leash and led from box to box. Each time the dog investigates the boxes, the order of the boxes is changed. The dog is reinforced using the ball whenever it is at the box with the vapour strips. It is important that the dog receives reinforcement when its head is pointed towards the hole in the box.

### Second step

After this procedure has been repeated several times, the ball is no longer placed in the box with the positive filter cartridge. It is now only the vapour strips in the one filter cartridge which distinguish the one box from all others, and the only way the dog can detect the positive is by using the sense of smell. The most important criterion for progress in the training programme is to observe whether the dog has recognised the scent. A positive observation of scent recognition is when the dog turns its head quickly in the direction of the scent source (indicating orientation reaction).

### Third step

After the dog has learnt to detect the correct box/filter cartridge by scent, training of the indication response begins (required behaviour for a dog on scent recognition). The dog is commanded by the trainer to sit as soon as it recognises the box containing the filter cartridge with the vapour strips. It is given reinforcement as soon as it sits. After numerous repetitions, the dog will sit automatically at the right box. Eventually, the dog must learn to point its head towards the hole (be focused) in addition to sitting, in order to get reinforcement. Throughout this procedure, the order of the boxes is constantly varied. The end target of this part of the training programme is to get the dog to investigate all the boxes, and on its own initiative to stop, sit and focus on the hole in the correct box.

### Fourth step

The next stage in the training programme is to place the filter cartridges on a T-shaped stand with a base so that it can be placed alone on the floor (Annex 1). The stands with the filter cartridges are placed along a wall 1-1.5 metres apart. The dog trainer leads the dog on the left-hand side on a leash from stand to stand. Reinforcement is only given when the dog identifies the correct stand, sits and points its head towards the filter cartridge (positive stand).

The positive stand is then moved each time the dog begins a new search. The dog is only allowed to move in one direction when it is investigating the row of stands, and at the end of the row it is led to the right before being taken back to the first stand to begin a new search.

Towards the end of the imprinting programme, the number of positive vapour strips

in the filter cartridge is progressively reduced from eight to one. This reduces the concentration of TNT and makes detection more difficult for the dog.

### *The training programme: improving discrimination*

#### **Stage 1**

The training programme continues as before, but with more stands containing filter cartridges in a row. The positive filter cartridges now only contain one vapour strip. The other filter cartridges contain elements intended to disturb the scent, initially vapour strips without TNT (negative strips) (Annex 1). These negative targets help train the dog to discriminate between the scent of paper and solvent from the scent substance of TNT.

During this stage, there is a higher requirement for procedures to reduce the risk of contamination. For example, sterile procedures are introduced for the handling of positive and negative filter cartridges. Disposable gloves are also used to prevent human scent as an alternative stimulus for the dog.

#### **Stage 2**

From stage 2, the vapour strips are no longer placed between the PVC netting in the filter cartridges. The positive filter cartridges for training are produced by placing one vapour strip in a 1 cubic metre box (1 m x 1 m x 1 m). The box is sealed with tape and left to stand for two hours before a vapour sample is taken from the box by suction using a vacuum pump. The sample is taken by making a hole in the top of the box, large enough to insert a filter cartridge. Air is sucked out for 60 seconds with a vacuum of 8 kp/min.

The box is resealed and after two hours a new positive sample can be taken.

#### **Stage 3**

The same procedure as with stage 2, but the vapour strip is left for only one hour between each sample with vacuum suction and filter. For each sample taken, the same suction time is used (60 seconds).

#### **Stage 4**

As for stage 3, but the suction time is reduced to 45 seconds for each sample.

#### **Filters for training**

In addition to positive filters for training, filter cartridges with genuine background scents from the area to be searched are also required. Filter cartridges with various background scents are produced using the same methods as for positive filter cartridges. Initially, various scent sources, e.g. diesel, cigarettes, food, waste, excrement etc., are placed in boxes. These are sealed with tape. Air samples are taken by vacuum and the filter cartridges are prepared in the same way as the positive filter cartridges.

From stage 2 in the training, filters with background scents are placed on stands as negative targets. Every second time the dog analyses the filters, a varying number of background scent filters are replaced in addition to moving around the positive filters. It is important to have a continual supply of new filter cartridges, taken from various environments. These must be placed in the row of filter cartridges as new filter cartridges, irrespective of whether the row contains positive or only negative filter cartridges.

### Assessment of dogs during training

For every stage of the training programme there is a written module directing the training programme, and for maintenance of records. The purpose is to assess the dog and trainer over the various stages of the training, and to determine whether the level of difficulty can be increased.

**Table 1**  
Evaluation table used by Mechem during the training process<sup>a)</sup>

| Evaluation | Weaning process for certification |              |                |              |
|------------|-----------------------------------|--------------|----------------|--------------|
|            | Clear rounds                      | False alarms | Positive found | Working time |
| 1 stage    | 2                                 | Max 30 %     | 50 %           | 30 minutes   |
| 2 stage    | 4                                 | Max 20 %     | 60 %           | 60 minutes   |
| 3 stage    | 6                                 | Max 10 %     | 70 %           | 90 minutes   |
| 4 stage    | 10                                | Max 5 %      | 85 %           | 120 minutes  |

a) The values in the table are required maxima or minima that the dog must achieve before it can move on to the next stage.

- During the evaluation of stages 1 and 2, the dog trainer knows whether there are positive filter cartridges in the row of stands or whether they are all negative. The dog trainer does not know where the positive filter cartridges have been placed.
- During the evaluation of stage 3, the instructor knows how many positive filter cartridges are included in the test, but their position is unknown.
- During the evaluation of stage 4, only the test leader has information regarding positive filter cartridges and their position.
- During the evaluation of stages 1-3, the dog trainer is informed when the dog indicates correctly for a positive filter cartridge. During stage 4, no information regarding positive filter cartridges will be given until after the test has been performed. During stage 4, filter cartridges with many different background scents will also be used to make the test more realistic.

### Maintenance training

The maintenance of search behaviour when checking filter cartridges shall be based on intermittent reinforcement (see definitions in Chapter 1, Part 2). It is essential for the dogs to maintain intensity of search behaviour without regularly detecting positive filter cartridges, if they are to be effective in operations. A gradual increase in the number of negative filter cartridges being checked between each positive filter cartridge should follow a scale of reinforcement based on a variable frequency. Each dog follows a reinforcement schedule adapted to the dog's performance during training and subsequently during normal follow-up training. In addition to reinforcement when a dog indicates a positive filter cartridge, there is also the possibility of giving reinforcement to a dog when it carries out a satisfactory investigation when all the filters are negative. In this case, reinforcement should be given after the dog has finished investigating the last filter cartridge in the row.

Reinforcers are only given when the dog indicates a positive filter, and the dog handler or trainer is aware that the filter is positive. When analysing unknown filters, reinforcers cannot be given as the trainer will not know which filter cartridges are positive, and



could reward a false indication. In order to ensure that reinforcers are not given when the dog indicates incorrectly, reinforcers are not given during the analysis of genuine filter cartridges at all. If a dog is to cope with the transition from the training stage to practical analysis of genuine filter cartridges, then the last stage of the training must be organised to resemble practical investigations of genuine unknown filters. This implies that the dog has to be led away from a correct indication of a positive filter without any reinforcer. Initially, this should only occur irregularly, but the frequency can be increased over time without any negative effect on the dog's performance. If leading a dog away from a positive indication is correctly managed, it will result in increased intensity in detecting positive filter cartridges. For this stage of the training, a reinforcement schedule is compiled based on a variable ratio, and used to support indication behaviour with positive filter cartridges.

### *Use of REST in the execution of survey contracts: scent trapping and analysis*

Mechem Consultants is one of the best equipped demining organisations in the world, mechanically and technically. One of the main reasons for the organisation's great success with quick and safe execution of demining contracts is its development of mine-protected vehicles. The Casspir vehicle has a specially designed V-shaped undercarriage which allows personnel to travel safely inside without risk of injury even if the vehicle was to trigger an anti-tank mine. Any damage to this type of vehicle from an anti-tank mine would normally be limited to a broken wheel shaft, which is relatively simple to repair out in the field.



*Casspir in the field.*

### **Scent trapping operation**

The Casspir vehicle has also been fitted with vacuum pumps for scent trapping operations. Two holders with filter cartridges are placed in front of the vehicle on each side as the vehicle moves forward. However, experience showed that this method was not satisfactory for scent trapping. Subsequently, Mechem carried out the majority

of their scent trapping operations using human teams, while maintaining continuous research into alternative methods.

The used filter cartridges are carefully logged and packaged then sent to Mechem's own base/laboratory for analysis by sniffer dogs.

### **The analysis process**

The analysis site is set up with 10-12 stands along a straight wall, 1-1.5 metres apart. One filter cartridge is placed on each stand. The walls and floor at the site are of polished concrete, allowing easy cleaning. The room is well-ventilated and allows for temperature and humidity control.

During the actual analysis process, as in training, the dogs are led on a leash from stand to stand by the dog handler. The dog is allowed only to move in one direction along the row of stands, and when it has sniffed the last filter cartridge it is taken from the room or taken back to the start of the row. In between each analysis, both the dog and the handler stand behind a screen so they cannot see the filter cartridges being moved.

All the filter cartridges are logged with a number and can be referred back to the GPS position where the sample was taken. There is also a continual log of the dogs' behaviour. Any errors or other deviations in behaviour should be systematised and, where necessary, corrected in maintenance training.



*Sniffing stand with filter cartridge (Mechem, South Africa).*



*The dog indicates and maintains focus on a positive filter cartridge (Mechem, South Africa).*

## Case study 2: Norwegian People's Aid

Norwegian People's Aid (NPA) is one of Norway's largest non-governmental non-profit organisations. Founded in 1939 by the Norwegian Labour Movement and applying the principles of solidarity, unity, human dignity, peace and freedom, NPA is involved in more than 400 projects in 30 countries.

NPA sees peace as arising not just from the absence of hostility, violence and war: economic and social justice, guarantees of human rights, and freedom from violence and gender-based discrimination are necessary conditions for human survival.

NPA is probably the world's largest humanitarian aid organisation working in the field of demining. From its foundation, the organisation has worked with development and rehabilitation programmes in various third-world countries, but from July/August 1992 (Cambodia) their work also included demining. In October 1994, the organisation launched its first MDD project in Mozambique. A total of eight dogs, German shepherds around one year old, were imported from Norway, and local dog handlers were appointed to carry out the training under the supervision of Norwegian instructors. In 1995, NPA acquired 29 dogs and handlers from the American-based RONCO, and by the end of the year had a total of 42 dog/handler teams in operation. In that same year, the decision was made to train dogs for projects in Angola. In 1996, dogs were sent to Bosnia and Herzegovina and Croatia to assist NPA with various tasks, which included digging up mass graves. These and the other dogs were all trained for free-running search tasks.

Where possible, NPA aims to employ local staff for all projects, including the dog projects. The organisation hopes that this principle will allow effective transfer of resources and know-how to those countries where the need for humanitarian services is greatest, and allowing eventual withdrawal of NPA from the programme. Application of the principle to dog projects has had varying results, as new and previously unknown problems were encountered. Local and cultural issues to do with acceptance of dogs by demining personnel have been significant in this regard, coupled with the need to develop entirely new operational procedures for management of a mine dog programme.

NPA has faced these challenges with a strong will to show innovation and initiative within non-traditional areas of operation. The organisation has invested considerable sums in the hope of making mine detection work more efficient. One of these initiatives was to approach the South African Government, resulting in an agreement where the REST system could be developed and tested under the guidance of Mechem Consultants, South Africa.

### *The REST project in Angola*

In January 1997, NPA started a REST project in Angola. Dogs, sampling equipment, vehicles and personnel were supplied by Mechem, and the target was to launch operations within six months. A number of difficulties were encountered, including uncontrolled contamination of the training area (at Lobito), which resulted in delays. Satisfactory results were only obtained when the dogs were moved to a new training area (Lubango). Since the autumn of 1998, the programme has maintained a high scientific standard, and many kilometres of road have been investigated and cleared of mines.

Until the present, NPA has used the REST system solely for investigation of roads, but is interested in adapting the system to investigate other surface areas. GICHD sub-study IVC (the Angola REST project) is the result. NPA requested GICHD to support a study investigating the potential for development of REST as an area clearance tool, using the resources of the dog project in Angola.

If the REST system continues to provide reliable results, NPA is interested in implementing the system as a part of their dog projects in a number of countries.

NPA has implemented the REST system in Angola by employing local dog handlers and other support staff. Before dog handlers are selected, they are provided with training in dog care, management and practical handling, and basic training in behavioural doctrine and the psychology of learning. Once they have completed the basic training, the best are selected as dog handlers. Instructors and other management personnel are appointed from Norway or other countries.

NPA has set up its own REST group with a project manager. This consists of a sampling team which is field-based, and an analysis team which operates the dogs at the base camp.

Sampling is carried out according to the procedures described early in this paper.

### *Collecting information*

Representatives of NOKSH AS visited NPA's REST programme in Angola in the autumn of 1998. They spent much of their time observing the dogs being trained in the REST system.

Information was collected via interviews and direct observation. Written observations and video recordings were used as documentation. Written reports were sent to those from whom the information was gathered for comments, corrections and approval, before being incorporated in the final report.

Information for this report has also been gathered from access to written material and meetings with personnel currently responsible for the organisation and practical execution of NPA's REST project.

### *Dog selection*

NPA prefers German shepherds or Labrador retrievers when recruiting new dogs for training in the REST system. Both genders are acceptable, but if a bitch is to be used, she must first be sterilised. A dog starting training should be around 12 to 18 months old. NPA also places stringent requirements on health, and demands X-rays of hips, elbows and back, and a full health check by an authorised veterinarian. NPA has also established strict routines for vaccination.

### *Selection*

There is no systematic testing of the dogs to be selected for training in the REST system. Qualified personnel make a general assessment of the dogs, focusing on qualities which, based on experience, have proved significant for training and maintenance. Important criteria for dog selection are as follows:

- The dog must be open-minded, accessible and cooperative.
- The dog must not be gun-shy or easily distracted by strange noises or movement.
- Good abreaction — the dog must not go into a state of stress in case of passivity.
- The dog must have a strong desire to search, a good ability to find what it is searching for, and retrieve willingly.
- The dog should not be easily distracted — the dog must have a high level of concentration.

A special test has been developed in order to gauge/observe which reinforcers provide the best response in a dog. The test is designed specifically to discover whether a ball or a kong is the best reinforcer for the dog.

The dog must be able to retrieve a stationary ball, but also be willing to follow and retrieve a ball/kong that has been thrown. It must be able to search for and pick up a ball/kong that has been thrown and is hidden in long grass. The dog must be willing to carry the ball/kong in its mouth for a minimum of one minute continuously without dropping it or giving it back to the dog handler.

If the dog exhibits behavioural patterns that match all these criteria, it is probable that a ball/kong will be a satisfactory reinforcer for the REST training programme.



*Sniffing stand with filter cartridges (NPA, Angola).*

## **Training**

Before initiating training, the dog handlers take some time to develop trust and a relationship with the dog. Although the dog handlers have already been through the basic training, they still spend some weeks just walking and feeding the dogs and playing with a ball/kong. It is especially important to ensure that the dog is not afraid or unsure of the handler.

All training starts off with basic obedience training. The dogs are first taught to sit, lie and then heel. After a short while, the dogs are taught to sit/lie at a distance, and finally to walk straight ahead at a distance of 20 metres in front of the handler.

Each team (dog and dog handler) is checked for these skills before training using explosives odours.

All training and analysis using dogs in the REST system is performed outdoors in real-life conditions, with training normally carried out in the shade of large trees.



The training area is most often located in an area near to the main camp, where the dogs are housed. At the time of writing, a building for filter analysis is being constructed. The areas to be investigated (the scent trapping operation) are most often at some distance from the main camp (many kilometres). In Angola, the filter cartridges from different parts of the country are brought to the main camp for analysis.

### *Explosive odour imprinting*

The strategically selected substance for the first section of training is TNT. The scent source is the vapour strips (see Annex 1) produced by Mechem Consultants, South Africa.

The equipment used consists of five stainless steel cylinders. One filter cartridge can be placed vertically in each cylinder. The cylinders are positioned on the ground in a semi-circle at a distance of five metres. Each cylinder must be marked so that it can be recognised by the dog handler, but without the dog being able to distinguish the markings in any way.

#### **First step**

A filter cartridge with five TNT vapour strips (positive filter cartridge) is placed in one of the five cylinders. Blank filter cartridges or filter cartridges with negative samples (negative filter cartridge) are placed in the four remaining cylinders.

The dog handler starts off with the dog on the left-hand side and with the first cylinder directly in front. A short leash and harness are used.

On the signal "Forward search", the dog handler moves forward to the first cylinder and shows it to the dog. They then move on to the second, third, fourth and fifth and stop at each cylinder. The fifth cylinder contains the positive filter cartridge. If the dog indicates sniffing behaviour towards the positive filter cartridge, the dog handler commands it to sit. As soon as the dog sits, it is reinforced with a ball/kong thrown nearby by a second person. Reinforcement must be given at the right moment when the dog is still sitting/lying and is focused on the positive cylinder. Once the dog has been reinforced, the search is complete, and the dog handler can join in playing with the dog and the thrown ball/kong. The ball/kong is then removed and the dog is ready for a new search.

On the next round, the cylinder with the positive filter cartridge is moved to a new position. This change is repeated every time the dog is reinforced for correct behaviour.

Each day, after training, the used filter cartridges are destroyed (most often burnt). This is most important for the positive filter cartridges, which must not be used for training over several days. Negative filter cartridges may be used several times and with several dogs during the earlier stages of the training.

#### **Second step**

Each search is started according to the same procedure as for the first step, but the distance between the cylinders is reduced from five to three metres. The dog must search independently without the dog handler following it. The dog will not receive any further signal after the command "Forward search". When the dog indicates correctly, by sitting by itself, it is reinforced by a support person throwing a ball/



kong at the right moment (“sit” and focused on the positive cylinder). If the dog should indicate incorrectly, by sitting at a negative cylinder, the command “No” is given and the dog is given the signal to continue searching.

#### Third step

The same procedure as for the second step, but now the cylinders are positioned at a distance of 1.5 metres only.

#### Fourth step

The same procedure as for the third step, but now the cylinders are positioned in a straight line at a distance of 1.5 metres.

#### Stage 1 (*Section 5 in NPA documentation*)

At this stage, the dogs must be able to detect the scent of TNT vapour strips and positively indicate this by sitting at the positive cylinder without any form of guidance. The number of vapour strips is reduced to four, then three, two and finally one vapour strip in each positive filter cartridge. The final procedure is incorporated, in which the dog is sent on a search along the row of cylinders on the signal “Forward search” and then returns to the dog handler. The dog handler stands three to five metres from the first cylinder when the dog is sent on its search. The dog is allowed to search for the cylinders in both directions, but is not allowed to change direction and go backwards and forwards. Dogs are also sent on searches where there are no positive filter cartridges in any of the cylinders.

*(At this point the training programme diverges from Mechem and NOKSH AS)*

#### Learning a new scent substance (type of explosive)

At this stage, the dog has to learn several new odour substances (types of explosive) by repeating the various steps (1–4) of the training in imprinting. A corresponding number (5) of vapour strips containing (e.g.) RDX are inserted in a filter cartridge and this is used as the positive filter cartridge. The cylinders are positioned in a straight line at equal distances, but the dog handler initially has the dog on a short leash and harness. The dog requires a varying degree of assistance initially by being commanded to sit when it is at the positive cylinder. Reinforcement with a ball/kong is given as previously.

The training is continued until the dog has achieved the same level of skill with the new scent substance, and can detect the new scent substance according to the same procedure as with TNT.

#### Training with two different scent substances

The same procedure is used here, with the dogs searching a row of five cylinders. The difference is that both scent substances (e.g. TNT and RDX) are used to create positive cylinders. The scents are not used at the same time in the row of cylinders, but the dog must learn to detect both scents when they are used in a positive filter cartridge.

#### Learning several new scent substances

When the dog has learnt the skill of detecting two scent substances, training procedures start for imprinting of new scent substances using the same methods. A total of five different odour substances (TNT, RDX, PETN, PE4 and DNT) are used as a part of the basic training in NPA’s REST project in Angola.

### **Stage 2 (Section 6 in NPA documentation)**

Positive filter cartridges are produced by directly sampling a pure scent substance of an explosive, e.g. TNT, for 30 seconds. This sample is used as the positive filter instead of using vapour strips. Similar positive filter cartridges are produced from various sources of odour substances of pure explosives (TNT, RDX, PETN, PE4 and DNT).

### **Stage 3 (Section 7 in NPA documentation)**

Positive filter cartridges produced according to the same guidelines as in stage 2 are used for training. Negative filter cartridges for training are produced by sampling various environments known to be uncontaminated with explosives. It is important to gather background scents from many different surroundings: grass, trees, rusting metal, etc. From this stage:

- Negative filter cartridges for training are only used on one day;
- The cylinders are replaced with stands (see Annex 1 —“T-stands”); and
- Dog handlers have no information regarding the status of the filter cartridges, whether there are any positive filter cartridges and if so, where they are placed. If the dog indicates correctly, a support person is on hand to confirm this and to give reinforcement.

### **Stage 4 (Section 8 in NPA documentation)**

The same procedures as for stage 3, but with reduced concentration on the positive filter cartridges. Concentrations are reduced gradually, first by sampling pure explosives for 30 seconds and finally by sampling slowly and directly over a mine (anti-tank or anti-personnel) lying on the ground.

### **Stage 5 (Section 9 in NPA documentation)**

The only difference between stages 5 and 4 is that the mines sampled are placed in a hole in the ground and covered with soil. Sampling is carried out at a new location, where mines have been under the ground for some time.

### **Stage 6 (Section 10 in NPA documentation)**

Sampling is now carried out over mines that have been under the ground for some time.

### **Stage 7 (Section 11 in NPA documentation)**

Sampling is carried out over a selection of a minimum eight different types of old buried mines.

### **Stage 8 (Section 12 in NPA documentation)**

The procedures are followed in accordance with the guidelines for analysis. Positive filter cartridges are sampled as a part of a genuine scent trapping operation.

## **Assessment of dogs during training**

Although a complete record of the training programme and results is kept, there is no systematic assessment of dogs during training. Instructors and trainers with lengthy experience are responsible for training and will continuously observe the quality of the dog/dog handler. Their observations form the background for a decision of whether the team should continue.

## **Maintenance training**

No information available.



*Dog and dog handler. Ready to send the dog on a search of filter cartridges (NPA, Angola).*



*Search of filter cartridges mounted on six stands in a row (NPA, Angola).*



*NPA uses German shepherds and Labrador retrievers for analysis in its REST project in Angola.*

### *The analysis process*

The various scent trapping teams send regular deliveries of filter cartridges to the main camp where the dogs are ready to carry out analysis. Analysis is organised at the location for daily training. All those taking part in the actual analysis process carry out their tasks according to detailed guidelines.

Each delivery of filter cartridges is accompanied by a list of specifications (see Annex 2, Fig. 1). When the filter cartridges are arranged for analysis, two cartridges from the same sector are placed on the same stand. A total of six stands are erected in a row, i.e. 12 filter cartridges are investigated simultaneously.

Qualified personnel keep a record of filter cartridges, dogs, dog handlers and site conditions for the analysis on a separate form (See Fig. 2 in Annex 2, which provides examples of sampling, analysis and assessment forms used in REST dog training).

### **Quality control of dogs to be used for analysis**

Before analysis, all dogs are tested for possible detection of positive filter cartridges (reliability). Each dog is put through a test where a minimum of 10 positive filter cartridges shall be detected from a selection of minimum 50 negative cartridges. All positive cartridges are produced by a normal scent trapping team from an area where mines and UXO are buried. The samples are taken according to procedures described in IMAS 09.43 and the sampling personnel have no information regarding the location of the buried objects.

Negative filter cartridges must be produced according to the same procedures as for the positive cartridges, but from an area where there is little probability of mines or trace substances of other explosives. Blank filter cartridges may not be used in the test.

The positive filter cartridges are placed at random on a row of six stands together with the negative cartridges. The dog handler has no information regarding the cartridges prior to the search. If the dog is unable to indicate a minimum of 70 per cent of the positive filter cartridges, then it has not achieved the minimum requirement for REST analysis.

After calculation of average reliability, a decision is made on the number of dogs to be used for analysis. If reliability is low, a larger number of dogs must be used than if reliability is higher.

The following formula provides a guideline:

- At least three dogs shall be used if the average team reliability exceeds 95 per cent;
- At least four dogs shall be used if the average team reliability is between 85 and 95 per cent;
- At least five dogs shall be used if the average team reliability is between 75 and 85 per cent;
- At least six dogs shall be used if the average team reliability is between 70 and 75 per cent; and
- A dog with an average reliability below 70 per cent should not be used for REST analysis.

### The analysis process and assessment of results

All analysis tasks are managed and supervised by qualified personnel, who are also responsible for keeping records of the analysis process. In addition to the dog handler, one support person is required and one/two other persons assist with preparation.

NPA's REST analysis team normally consists of four dogs to investigate each filter cartridge. This number may vary depending on the average reliability continuously gauged during testing.

If it is assumed that four dogs are used to investigate a number of filter cartridges, then an area will be declared as potentially mined if one or more dogs indicate a filter. If only one dog indicates, then that area may be sampled and analysed once again. The filter cartridges from this same area will be investigated by all the dogs once more. If, once again, only one dog indicates a positive filter cartridge, then the area will be declared as potentially mined. If the results show that none of the dogs indicate positive cartridges during the second round of analysis, then the area will be declared free of mines. During a second analysis of one area, a number of positive filter cartridges are used in all searches to prevent the dog handler from speculating as to which search might contain a double check.

## Case study 3: Norsk Kompetansesenter for Spesialsøkshund AS (NOKSH AS)

Norsk Kompetansesenter for Spesialsøkshund AS is located in Øs, near Bergen, Norway. The company is a centre for know-how in training and practical use of specially trained sniffer dogs, and has also developed significant skills in the transfer of training results from one dog handler/trainer to another.

### *Organisation of the work*

NOKSH AS has previous experience of the REST system from working with NPA, and has also seen the system in practice when visiting NPA's dog project in Angola, and through visits to Mechem, including a course in 1998.

For this project, NOKSH AS carried out the training of four dogs in the REST system according to Mechem's guidelines. NOKSH AS appointed one of their staff to act as trainer and to assume technical responsibility for the practical execution and reporting of results.

NOKSH AS received a vacuum pump (back-pack) and filter cartridges from Mechem, together with the necessary users' instructions and guides. Premises for training and kennels for the dogs were rented from Fjellanger Dog Training Academy AS (FDTA).

### *Selection of dogs*

NOKSH AS used hunting springer spaniels or springer-Labrador crossbred dogs. Dogs were obtained either by purchase in England, or by breeding at the kennels of Fjellanger Training Academy. The general qualities required in a dog to ensure that it can be trained for REST are:

- The dog must respond well to reinforcement using different aids. The use of



- different aids or reinforcers improves the efficiency of the training process.
- The dog should maintain an activity requested by the inspecting agent without becoming distracted by other activities — this is a good sign of perseverance and the capacity to focus on the task at hand.
- The dog must not be distracted in situations which include an element of surprise or threat, and should relax immediately after being released from a stressful situation. If the dog has these qualities, it will be expected to be able to manage interference in its surroundings and a change of environment, with little effect on the results achieved during training or in practical work.



*Explosive odour imprinting. Skinner, during the early training stages with box.*

### The selection process

The dog should be between one and two years old when it goes through the tests. The test results shall be used to assess whether the dog possesses the necessary qualities and can begin training. In addition to tests of the dog's behavioural patterns, a veterinarian must also carry out standard medical checks on the dog.

Manuals for charting behavioural patterns have been developed by NOKSH AS using experience from training and practical use of sniffer dogs. The forms compiled are intended to facilitate the assessment of a dog's qualities/skills when performing such tasks. All behaviour assessed is considered of importance when sniffer dogs are to start training and are later to be used as service dogs.

Dogs for the REST system are assessed in three different areas: intensity/response to reinforcers, searching activity, and reactions to environmental factors. For other types of sniffer dogs such as drug detection dogs or field-search mine detection dogs, a higher number of tests are carried out because a wider variety of skills are needed.

It is not possible to compile tests such as these using strict quantitative measures. Qualitative records are kept based on the manner/response observed when the dog is faced with a certain set of procedures initiated by the test administrator. An example



used in practice is given in Table 2. Once the test has been started, all the procedures must be carried out continuously without a break.

Each part of the test follows guidelines presented as brief procedures. Records are taken according to observations and assessments categorised as inclusive or exclusive. Inclusive assessments entail all actions or observed responses which are considered positive for the training and practical use of the dog for the purpose in mind. Exclusive assessments entail all actions or observed responses which are considered negative for the training and practical use for the same purpose (Table 2).

The administrator supervises the test and is also responsible for recording responses during the test. The test shall be carried out in a new environment for the dog, and one person (owner/trainer) with whom the dog is familiar shall be present. The test administrator should not be a person with whom the dog is familiar. The dog shall be put on a long leash, which will hang free during the test. The test starts when the dog and administrator meet for the first time.

Procedures for recording reinforcers are used first, followed by procedures that focus on search behaviour, and finally several procedures which focus on the dog's reactions to different environments.

#### **Practical execution**

Table 2 contains a list of procedures/situations (1-7) and an order for carrying them linked to the reinforcers given. The list also contains two columns where behaviour is categorised as inclusive or exclusive. After one procedure from the list has been carried out, the exclusive/inclusive columns are marked off when a certain response has been identified.

*Equipment:* Titbits (meat and dried food), ball (tennis ball), rag on string, kong on string. Long leash (10 m) hanging free behind dog. Short leash.

The test results are assessed as a total after the dog has been through all the procedures for one given area. There must be a majority of inclusive categories in all areas for the dog to be considered suitable for training. A smaller number of exclusive categories is expected.

#### **Training**

Descriptions of the methods used by Mechem (South Africa) and NPA (Angola) given above are largely based on direct observations of training and demonstrations during study visits by representatives of NOKSH AS. The training programme developed at NOKSH AS for the four REST dogs applied the techniques exactly as used by Mechem, except in relation to odour imprinting. This report contains an analysis of the NOKSH AS methods with suggestions about proposed improvements to the training programme used by Mechem, based on the experiences at NOKSH AS. The first section follows the same structure as for the case studies above. The second section is a summary analysis of the training results for the NOKSH dogs. A more detailed description is available in Fjellanger, Andersen and McLean ([www.gichd.ch/Research/McLean\\_REST\\_dogs\\_1.pdf](http://www.gichd.ch/Research/McLean_REST_dogs_1.pdf)).

The alternative training procedures developed by NOKSH AS with respect to imprinting offer increased efficiency of record keeping. Operationally, the dogs

**Table 2**  
**Example of reinforcement procedures applied during the selection process**  
**for a potential REST dog**

| Procedure/situation   | Inclusive  | Exclusive   |
|---|--|---|
| 1. Dog presented with titbit, first meat then dried food.   | <ul style="list-style-type: none"> <li>➤ accepts (eats) all types of titbits</li> </ul>  | <ul style="list-style-type: none"> <li>➤ does not accept food or accepts just good titbits (not dried food)</li> </ul>  |
| 2. Dog presented with following in given order, ball, rag on string and kong on string. All three objects dropped directly on ground after presentation.    | <ul style="list-style-type: none"> <li>➤ follows and picks up ball/rag/kong while moving</li> <li>➤ active playing with administrator, carries ball/rag/kong, can also maintain activity after administrator becomes passive</li> </ul>    | <ul style="list-style-type: none"> <li>➤ no activity when presented with ball/rag/kong or other toy</li> <li>➤ does not run after ball/rag/kong which has been thrown</li> </ul>  |
| 3. Administrator starts game and activity using titbit/ball/rag on string and kong on string.   | <ul style="list-style-type: none"> <li>➤ willingness to be led/commanded by using titbit/ball as aid</li> </ul>  | <ul style="list-style-type: none"> <li>➤ stands still and cannot be activated, starts another activity, moves away from administrator (e.g. sniffing, urinating, looking for contact with dog handler etc.)</li> </ul>  |
| 4. In the order given, the ball, rag on string and kong on string are thrown 15-20 metres. The dog is let off the leash while the objects are still moving. | <ul style="list-style-type: none"> <li>➤ drops the ball/rag/kong without fighting (may be exchanged for titbit or other ball/rag/kong)</li> <li>➤ carries the ball/rag/kong without dropping it or switches to another activity</li> </ul> | <ul style="list-style-type: none"> <li>➤ displays signals of moderating aggression</li> </ul>   |
| 5. Behaviour towards the object when the dog is at a distance from the dog handler and administrator.   |  | <ul style="list-style-type: none"> <li>➤ follows ball/rag/kong which is moving but does not pick up</li> </ul>  |
| 6. Behaviour towards the object when the dog is near the dog handler and administrator.   |  | <ul style="list-style-type: none"> <li>➤ little/no interest in picking up/carrying ball/rag/kong</li> <li>➤ moves away from ball/rag/kong when these are stationary</li> </ul>  |
| 7. Activity after activation completed.   |  | <ul style="list-style-type: none"> <li>➤ interrupts activation to take up other activity (e.g. sniffing, urinating, looking for contact with dog handler etc.)</li> <li>➤ does not drop ball/rag/kong without fighting or when presented with alternatives</li> <li>➤ starts own activity (stones, sticks, objects in movement) without any form of stimulation from administrator/dog handler</li> </ul> |

training that the NOKSH AS procedures appear to provide greater efficiencies. The description of the NOKSH AS training programme is provided below. The next section is equivalent to the descriptions provided in the two case studies of Mechem and NPA above.

### *Explosive odour imprinting*

The selected target substance for the training process is TNT. The scent source is vapour strips (Annex 1) produced by Mechem Consultants, South Africa.

Training is held in a room (4 metres x 4 metres) with good ventilation, and temperature and humidity control. A special apparatus was developed for training of sniffer dogs (ADSM) (Annex 1).

Imprinting training, and training in behavioural patterns when indicating recognition of a scent, were developed using *shaping* (see Chapter 1, Part 2). Sounds (whistle or “clicker”) are used as a reinforcer. The choice of reinforcer used to maintain the clicker as rewarding is made based on observations during the selection process.

#### **First step**

Before commencing training, a box is mounted on the ADSM. The source material is a vapour strip with TNT, which is placed in the box with the top closed. The dog is led into the room and a shaping procedure starts immediately. The first aim (response) is to get the dog to move towards the box on the ADSM. The next is to get it to touch the top of the box with its snout. Best results are achieved with short training sessions of 10-15 minute intervals. The dog is reinforced by the dog handler each time it displays a correct form of behaviour, and is later only reinforced when it touches the top of the box with its snout. Finally, the dog itself begins to control occurrence of reinforcers by behaving correctly. If it touches other parts of the apparatus, it receives no reinforcement.

#### **Second step**

Two boxes are now mounted diagonally on the ADSM. One box with the TNT vapour strip (positive box) and one empty box. The dog is reinforced when it puts its snout on the positive box, and is ignored if it puts its snout on the empty box. The apparatus is designed to allow rotation of the boxes so that the position can be changed between sessions. Most often, the dog will develop a behavioural pattern of trying out one box, and switching to the other one if no reinforcement occurs. It therefore achieves reinforcement for 50 per cent of its first attempts. As there are only two boxes on the apparatus, scent will be established only slightly as a discriminative stimulus.

#### **Third section**

Four boxes are mounted on the ADSM, with one containing the TNT vapour strip and the other three empty. The dog is reinforced when it puts its snout on the positive box and is ignored at the other three. Now there is less potential for random distribution of reinforcer, but the result is often a higher degree of activation and most often the dog will now start to use its sense of smell. The progression from two to four boxes will be difficult for some dogs, and it may be necessary to do more work with two boxes. If four boxes is too difficult for the dog, it may stop putting its snout on the boxes and appear uninterested. If it becomes completely passive, it might help to give a short break or let it repeat a few sessions with only two boxes on the apparatus.

Behaviour provoked as a reaction to odours will be displayed initially by the dog turning its head in the direction of the box (odour source) with a quick movement (displaying orientation reaction). It is important that the trainer registers this reaction and gives immediate reinforcement. A signal (whistle or “clicker”) must be used immediately. Even if the dog has not placed its snout in contact with the box when the signal is used, in a situation such as this it will be the actual sense (scent) which is reinforced.

A number of successful repetitions where orientation reaction (sense of smell) is reinforced will result in a more reliable behavioural pattern, and the dog will gradually stop at the right box. The boxes are continually rotated so that the position of the positive box varies. Towards the end of this section, two new empty boxes are mounted on the ADSM, so that training now involves six boxes.



*Explosive odour imprinting. Skinner searching with several boxes mounted on ADSM (NOKSH AS).*

#### Fourth step

Six boxes are mounted on the ADSM, one with TNT vapour strip and the other with vapour strips without TNT (negative boxes). Strict procedures are now followed for all handling of odour substances and equipment in order to avoid contamination. This entails set routines for the use of disposable gloves, replacing the top of the boxes, cleaning equipment etc. The fact that all the boxes contain an odour (vapour strips) makes it more difficult to detect the positive box. The odour of TNT is the distinguishing factor. These other odours may result in random responses from some dogs and they may stop/reduce search behaviour. In such cases, the immediate strategy is to reduce the number of boxes (six to four), and return the focus of reinforcement to the minor changes in behaviour that the trainer uses to monitor the ability of the dog to respond to the positive target. The orientation of the dog to the target may initially be expressed by very small behaviours. Identification and precise rewarding of those behaviours (using the clicker) will significantly aid the trainer in reinforcing the dog's orientation towards the target.

We do not recommend attempting to increase activity levels by using different reinforcers to create a higher search intensity. The effect may be increased activation, but the result is often unwanted behaviour such as licking, biting, using the paw and in some cases barking.

When an odour discrimination (TNT vapour strip) has been established, progress can be made in the programme. The next target is for the dog to stop moving when it detects a positive box, and eventually to stand still for some time. The end target for this training section is to get the dog to detect the positive box, stop and stand still for up to five seconds before any reinforcement.



*Explosive odour imprinting. Hindi indicating a box (NOKSH AS).*

#### **Fifth step (a)**

Training begins for signalling detection (indicating). Training starts by reinforcing random (spontaneous) sitting. This must be done in all situations, environments and at different times of day when the dog sits spontaneously (without any form of help/influence). An increase in sitting frequency soon occurs. Stimulating reinforcers (ball/rag/kong) may be used for this training. The last repetitions of the spontaneous training are carried out in the premises used for imprinting, but without any ADSM assembled in the room.

#### **Fifth step (b)**

Two boxes are mounted on the ADSM, one containing the TNT vapour strip and one empty. When the dog stops at the positive box, the dog handler stands passively. If the spontaneous *sitting* behaviour has been sufficiently repeated, the dog may sit now by itself without any signal or other form of help from the dog handler. Reinforcement is given immediately if the dog sits. After each reinforcement, the position of the boxes is changed by rotation of the apparatus. The dog handler also changes position to be initially standing diagonally to the positive box. Later, the handler will vary position and finally be in constant movement. If the dog does not indicate (by sitting) spontaneously, it is best to repeat step 5a.

As soon as the dog sits spontaneously several times at the positive box, the ADSM is equipped with more boxes. At the same time, shaping procedures are used to gradually extend the length of time the dog has to sit and eventually to get the dog to point its snout towards the top of the box.

### Stage 1

Search training with the ADSM will from now on be subject to set procedures/routines; starting a search, ending a search, direction of movement while searching and duration of each search.

The procedure for starting a search is incorporated each time the dog is taken into the room. The dog is commanded to sit before it is allowed to search the boxes and is led to search in the same direction each time. During search training with the ADSM, the set direction is counter-clockwise. If the dog ends the search or starts to move in the opposite direction, it is stopped by the dog handler and led immediately to restart the search. The end target is to achieve continuous search of all the boxes in one direction.

At certain intervals, the positive box can be replaced with a negative box. Searches performed with the ADSM holding only negative boxes are known as blank trials. Initially there are very few blank trials, then the frequency can be increased, based on observations of the search duration for each dog. Varying the number of blank trials between each time the positive box is used ensures variation in reinforcement conditions (see “Reinforcement”, Chapter 1, Part 2).

The number of boxes on the ADSM is gradually increased from six to 12. The procedures for starting a search and correct movement patterns are maintained. Blank trials are at a low frequency during the period when the number of boxes is gradually increased.

### *From box to filter cartridge*

Once the dog has reached a level of skill entailing detection of TNT vapour strips, sitting to indicate positive box and search of 12 boxes in a row, then it is time to replace the boxes with filter cartridges.

One vapour strip with TNT is placed in a filter cartridge (positive filter cartridge) and placed on the ADSM. The other 11 filter cartridges are placed on the apparatus without any vapour strips. The positive filter cartridge, the only one with a vapour strip, is relatively easy to detect and the transition from box to filter cartridge does not normally lead to any significant problems.

In some cases, the dog may lick or bite the filter cartridges. This type of behaviour must be stopped immediately. It may help to have a leash on the dog in this situation and this will also allow for continuity of movement during the search. However, it is important not to overdo the use of the leash as it may influence the dog during the detection process. The leash is there as a device to control the activity of the dog. It must not be used for checking or jerking (a form of punishment).

If the dog displays satisfactory sitting behaviour and immediately indicates detection of the positive filter cartridge, then vapour strips without TNT are placed in the other 11 filter cartridges (negative filter cartridge). If problems are encountered, then it is best to use the small changes in behaviour (orientation reactions) to re-establish satisfactory responses.



Even if the dog progresses steadily, it may at times be necessary to change/improve certain elements of the dog's behaviour. It is most often preferable to make use of this stage of progress for such adjustments. At a later stage in the training the concentration of TNT will be lower and more difficult to detect. The dog's reactions may often be weaker, the risk of contamination higher and subsequently the potential for mistaken distribution of reinforcers higher.

### Stage 2

Positive filter cartridges for training are produced according to the same procedure described by Mechem. The TNT vapour strips are placed in large boxes (0.93 m<sup>3</sup>). The boxes are sealed with tape and after two hours, air samples are taken from the box using a vacuum pump. The samples are taken out through a hole in the top of the box, large enough for inserting a filter cartridge. For each sample, a suction time of 60 seconds is used at a vacuum of 8 kPa/min.



*The boxes on the ADSM have been replaced with holders for filter cartridges. Hindi indicates and maintains focus on positive filter cartridge (NOKSH AS).*

All samples are recorded in a journal. If any problems are encountered with the detection process, potential sources of defects can be traced back to the sampling process. Results from other studies indicate significant variation in concentration depending on temperature and humidity (Phelan and Barnett, 2001). Guidelines for taking samples for training have not been compiled, but there is a degree of standardisation to be found in the procedures for sampling compiled by NOKSH AS. Nonetheless, this problem requires more research so that training materials can also

be secured. If the quality of the dog is to be ensured, then the training conditions must also be standardised.

### Stage 3

The procedures for producing positive filter cartridges are the same as those for stage 2, but the filter cartridges are left to evaporate in the box for one hour only between each sample taken. Suction time remains at 60 seconds for each sample.

### Stage 4

The lowest concentration is sampled with a suction time of 45 seconds, after one TNT vapour strip has been left in the box for one hour.



*Skinner also maintains focus when detected positive filter cartridge (NOKSH AS).*

### *Monitoring progress: methods and results for assessment of dogs during training*

From stage 1 of the training programme, the individual dog's progress is supervised via a continuous record of training results recorded as a journal, using data sheets and sometimes video (see Annex 2, Fig. 3). A journal is kept of all daily activities in the test arena, recording working routines for how the dogs are prepared for training/analysis, feeding routines and practice, walking and other care. Data gathering technology could be used to help perform this task in one operation (e.g. a type of palmtop computer and associated software), although this was not done by NOKSH AS. The training sessions are organised to vary the order in which the dogs are trained and ensure that there is a randomised structure for each day/session. Physical parameters such as date, time, temperature before/after and humidity at start/end are recorded for each session and each dog.

Recorded information may be used to plan training, to document the quality of each dog, and to monitor progress on a regular basis (daily, weekly, etc). Systematic records kept during training allow charting of the level of skill for each dog. Analysis of the records indicates deviations and whether interventions are required, or whether the dog should continue in the training programme.

## *The training programme for REST dogs at NOKSH*

### **Methods**

Preliminary training for extended search, odour discrimination skills, and working with the multiple choice apparatus began in early January 2001, and was completed by early-mid February (5 weeks, 1-2 trainers, 4-5 days/week, 5 hours/day). Two trainers worked with all dogs in order to minimise the possibility of trainer-dog dependencies developing.

In early February, training to develop skills specific to the requirements of an operational REST dog began. At this stage, the dog understood the training apparatus, had basic discrimination skills for TNT, and was focused on search and discrimination; but a reduced detection threshold and reliable indication were not yet established.

From early February to mid-May, one or two trainers worked with the dogs on most working days (i.e. 5 days/week) for about 5 hours each day, but the training activity on each day varied. Within any one week, testing of the dogs was conducted on 1-4 days, but most dogs received training on some aspect every day. On non-testing days, the trainers worked with each dog to improve general skills, and also to fix problems identified in the training results. Dogs that performed poorly at any stage received extra attention in order to keep the dogs to a similar standard.



*The multiple-choice training apparatus with Hindi checking a filter. As training progressed, the number of arms on the apparatus was increased to 12.*

The dogs were challenged to discriminate one target (or positive) filter from a total of 12. A *trial* is one event in which a dog searches all filters on the test apparatus on a test day. The average number of trials per dog per day was ( $X \pm s.e.$ ) Bandura:  $16.9 \pm 0.5$ ,  $N=27$  days, range=6-35; Skinner:  $17.1 \pm 0.5$ ,  $N=29$ , range=5-36; Sam:  $18.4 \pm 0.5$ ,  $N=28$ , range=5-38; Hindi:  $17.8 \pm 0.5$ ,  $N=29$ , range=4-35. For some trials, no target was provided, and for some trials one target was provided.

Thus the dog returned any of the following possible responses:

- i) indicated the target = correct response = Cr,
- ii) gave no indication when there was no target = correct response = Cnt,
- iii) indicates when there is no target = false alarm when negative = Fa,
- iv) miss a target = false alarm when positive = Fm. *Mistakes* are Fa+Fm.

It was possible for a dog to make more than one mistake on a trial, for example because it gave several separate false indications during that trial. However, it was only possible to return one correct result for a trial.

The results are presented in Fig. 1 as the proportion of the total number of possible responses that were correct, on each test day:  $(Cr+Cnt)/(Cr+Cnt+Fa+Fm)$ . The number of test days within a week varied, so all available daily proportions were combined to give a weekly average. In Fig. 2, a value of 1 indicates perfect correct responses and a value of 0 indicates that all trials involved a mistake. The dogs are expected to get at least some trials correct by chance (e.g. on a “no target” trial), so the chance of a 0 being returned was very small.

Figure 1  
Proportion of correct indications during trials conducted over 15 weeks by four dogs during training for development as operational REST dogs. 1=all trials in a week correct; 0=mistake on every trial in the week. No test data were available for weeks 10, 12 and 13

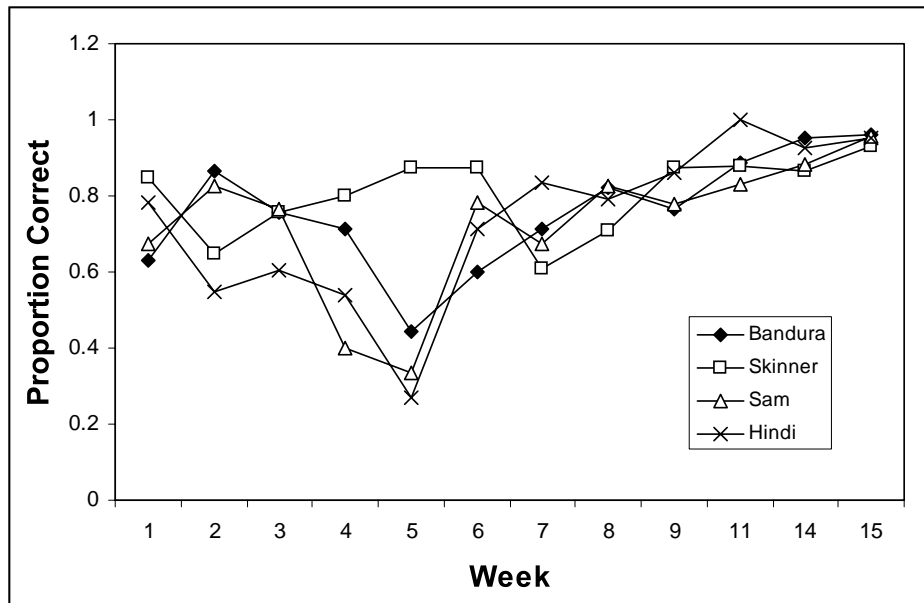

The two types of mistake required different training corrections. Fa is a training problem because it suggests that the dog is giving indications to manipulate the trainer. Fm is a discrimination problem and suggests that the dog needs more work on its detection skills. Therefore, the relative occurrence of each mistake through time was explored using the formula  $Fa/(Fa+Fm)$ . The results of this analysis were extremely variable, in part because of decreasing numbers of errors towards the end of the time series, so the curves were smoothed using a running mean calculated from the ratios for  $(week-1)+(week\ 0)+(week+1)$ .

Figure 2

False alarm indications (a non-target is indicated as positive, Fa) as a proportion of the total number of mistakes (Fa + missed targets, Fm) made by four dogs during training over 15 weeks for development as operational REST dogs. 1=all mistakes were Fa; 0=all mistakes were Fm. No test data were available for weeks 10, 12 and 13.

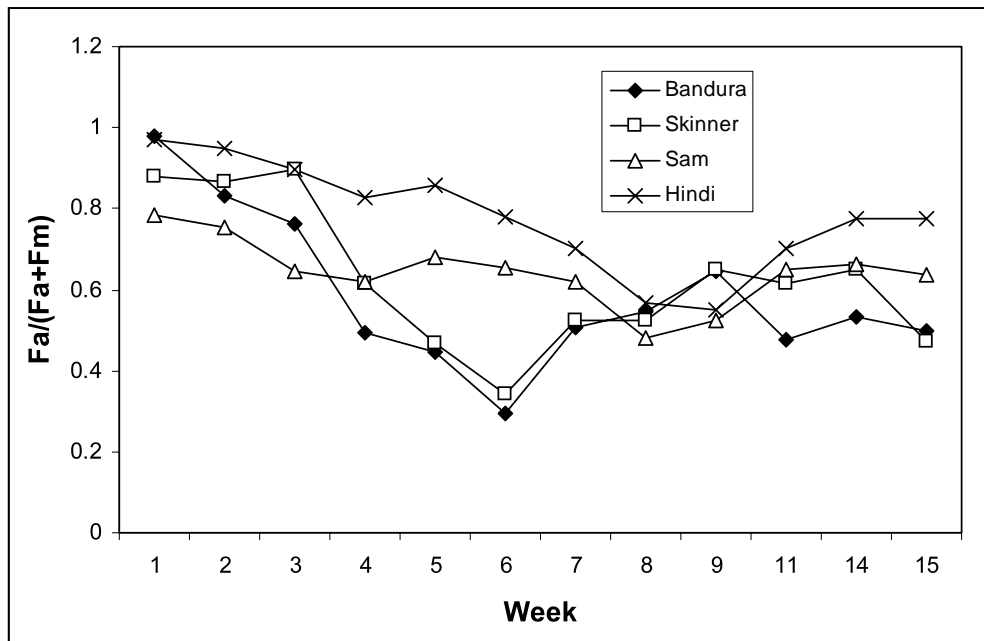

## Results

Throughout the training programme, the dogs worked on the search problem with great enthusiasm. They were always excited to enter the room, worked their way quickly around the 12 filters, and as enthusiastically left the room (they were sometimes rewarded outside the door after a search). There was never any suggestion in their behaviour that they found the repetitive training scenario dull or uninteresting, and the presence or absence of trainers had no influence on their search behaviour.

The pattern for three dogs was for the proportion correct to decrease over the first five weeks of training, after which the proportion correct increased rapidly, then more slowly but reliably towards the desired objective of no mistakes (Fig. 1). The fourth dog (Skinner) showed a somewhat different pattern by maintaining the proportion correct reasonably consistently around 80 per cent until week 7, when a sudden increase in errors occurred. This change was quickly corrected before he moved reliably towards the training objective of no mistakes. The dogs (in order Bandura, Skinner, Sam, Hindi) attained final proportion correct ratings of 96 per cent, 93 per cent, 95 per cent and 95 per cent. For trials in the final testing week where a target was provided (i.e. using values for Cr only), the proportion correct indications were 95 per cent of 22, 88 per cent of 23, 86 per cent of 15 and 95 per cent of 20.

At five weeks, specific training intervention was given to address the increasing proportion of mistakes being given by two dogs (Sam and Hindi). The effect of that intervention can be seen in Fig. 1. At this time the other two dogs (Bandura and Skinner) were showing an increasing proportion of missed targets (Fm, Fig. 2), even though Skinner was not exhibiting the general pattern shown by the other three dogs of an increasing proportion of mistakes overall. It appears that 5-7 weeks was a critical

**Table 3**  
 Results of trials conducted over 15 weeks for four dogs during training for development as operational REST dogs. Listed are the trial date, the total number of trials on that day (C), correct indications (Cr), correct no indication when there was no target (Cnt), total mistakes (F), false alarms when no target (Fa), and false alarms when target available (Fm). Columns C and F were used to calculate the proportions presented in Fig. 1

| Bandura    | Skinner |    |     |    |    | Sam |            |            |    |     | Hindi |    |    |    |            |            |     |    |    |    |    |            |            |            |    |    |    |    |    |    |    |
|------------|---------|----|-----|----|----|-----|------------|------------|----|-----|-------|----|----|----|------------|------------|-----|----|----|----|----|------------|------------|------------|----|----|----|----|----|----|----|
|            | C       | Cr | Cnt | F  | Fa | Fm  | n          | C          | Cr | Cnt | F     | Fa | Fm | n  | C          | Cr         | Cnt | F  | Fa | Fm | n  |            |            |            |    |    |    |    |    |    |    |
| 05/02/2001 | 12      | 5  | 7   | 1  | 0  | 1   | 13         | 07/02/2001 | 26 | 19  | 7     | 0  | 0  | 26 | 07/02/2001 | 16         | 11  | 5  | 10 | 0  | 19 | 07/02/2001 | 11         | 7          | 4  | 0  | 0  | 11 |    |    |    |
| 07/02/2001 | 13      | 6  | 7   | 8  | 0  | 16  | 08/02/2001 | 9          | 4  | 5   | 1     | 1  | 0  | 10 | 08/02/2001 | 17         | 10  | 7  | 0  | 0  | 17 | 08/02/2001 | 11         | 5          | 6  | 2  | 0  | 12 |    |    |    |
| 08/02/2001 | 16      | 9  | 7   | 15 | 15 | 0   | 24         | 09/02/2001 | 16 | 6   | 10    | 5  | 0  | 17 | 09/02/2001 | 9          | 5   | 4  | 5  | 0  | 14 | 09/02/2001 | 17         | 10         | 7  | 6  | 6  | 0  | 18 |    |    |
| 09/02/2001 | 0       | 0  | 0   | 0  | 0  | 0   | 0          | 12/02/2001 | 15 | 8   | 7     | 17 | 17 | 0  | 25         | 12/02/2001 | 0   | 0  | 0  | 0  | 0  | 0          | 0          | 0          | 0  | 0  | 0  | 0  | 0  | 18 |    |
| 12/02/2001 | 8       | 4  | 4   | 1  | 1  | 0   | 9          | 13/02/2001 | 9  | 4   | 5     | 1  | 0  | 1  | 10         | 13/02/2001 | 12  | 7  | 5  | 2  | 2  | 0          | 12         | 13/02/2001 | 10 | 4  | 6  | 13 | 12 | 1  | 17 |
| 13/02/2001 | 11      | 6  | 5   | 2  | 2  | 0   | 15         | 14/02/2001 | 13 | 4   | 9     | 2  | 0  | 2  | 15         | 14/02/2001 | 21  | 11 | 10 | 5  | 2  | 3          | 20         | 14/02/2001 | 16 | 8  | 8  | 9  | 8  | 1  | 24 |
| 14/02/2001 | 15      | 7  | 8   | 1  | 0  | 1   | 16         | 19/02/2001 | 18 | 14  | 4     | 0  | 0  | 18 | 19/02/2001 | 18         | 9   | 9  | 6  | 6  | 0  | 21         | 19/02/2001 | 16         | 8  | 8  | 1  | 1  | 0  | 16 |    |
| 19/02/2001 | 18      | 13 | 5   | 10 | 7  | 3   | 19         | 20/02/2001 | 11 | 8   | 3     | 11 | 9  | 2  | 20         | 20/02/2001 | 8   | 5  | 3  | 1  | 1  | 2          | 9          | 20/02/2001 | 19 | 14 | 5  | 9  | 9  | 0  | 21 |
| 20/02/2001 | 6       | 4  | 2   | 0  | 0  | 0   | 6          | 21/02/2001 | 6  | 4   | 2     | 2  | 2  | 0  | 6          | 21/02/2001 | 5   | 3  | 2  | 1  | 1  | 0          | 5          | 21/02/2001 | 4  | 3  | 1  | 0  | 0  | 0  | 4  |
| 21/02/2001 | 8       | 6  | 2   | 4  | 1  | 3   | 10         | 23/02/2001 | 5  | 5   | 0     | 0  | 0  | 0  | 5          | 23/02/2001 | 5   | 5  | 0  | 3  | 1  | 2          | 6          | 23/02/2001 | 13 | 11 | 2  | 24 | 21 | 3  | 22 |
| 23/02/2001 | 10      | 5  | 5   | 4  | 3  | 1   | 16         | 26/02/2001 | 12 | 5   | 7     | 3  | 3  | 0  | 14         | 26/02/2001 | 8   | 6  | 2  | 12 | 8  | 4          | 15         | 26/02/2001 | 14 | 9  | 5  | 12 | 10 | 2  | 15 |
| 26/02/2001 | 4       | 0  | 4   | 5  | 1  | 4   | 8          | 07/03/2001 | 7  | 1   | 6     | 1  | 0  | 1  | 8          | 07/03/2001 | 5   | 2  | 3  | 10 | 5  | 5          | 12         | 07/03/2001 | 7  | 4  | 3  | 19 | 14 | 5  | 18 |
| 07/03/2001 | 13      | 6  | 7   | 2  | 0  | 2   | 15         | 15/03/2001 | 14 | 5   | 9     | 2  | 1  | 1  | 15         | 15/03/2001 | 11  | 6  | 5  | 5  | 4  | 1          | 15         | 15/03/2001 | 16 | 9  | 7  | 11 | 11 | 0  | 21 |
| 15/03/2001 | 14      | 10 | 4   | 16 | 7  | 9   | 19         | 16/03/2001 | 20 | 6   | 13    | 3  | 1  | 2  | 22         | 16/03/2001 | 18  | 8  | 10 | 3  | 3  | 0          | 20         | 16/03/2001 | 19 | 8  | 11 | 3  | 3  | 0  | 21 |
| 16/03/2001 | 12      | 3  | 9   | 1  | 0  | 1   | 13         | 20/03/2001 | 14 | 4   | 10    | 7  | 7  | 0  | 19         | 20/03/2001 | 12  | 4  | 8  | 7  | 4  | 3          | 17         | 20/03/2001 | 13 | 4  | 9  | 2  | 2  | 0  | 14 |
| 20/03/2001 | 13      | 5  | 7   | 9  | 3  | 6   | 19         | 22/03/2001 | 11 | 6   | 5     | 9  | 3  | 6  | 19         | 22/03/2001 | 13  | 4  | 9  | 5  | 3  | 2          | 18         | 22/03/2001 | 12 | 4  | 8  | 3  | 1  | 2  | 15 |
| 22/03/2001 | 16      | 3  | 13  | 4  | 3  | 1   | 18         | 26/03/2001 | 15 | 6   | 9     | 6  | 2  | 4  | 20         | 26/03/2001 | 15  | 5  | 10 | 2  | 1  | 1          | 16         | 26/03/2001 | 17 | 4  | 13 | 3  | 2  | 1  | 16 |
| 26/03/2001 | 12      | 2  | 10  | 2  | 2  | 0   | 14         | 29/03/2001 | 12 | 4   | 8     | 5  | 4  | 1  | 14         | 29/03/2001 | 9   | 3  | 6  | 3  | 1  | 2          | 10         | 29/03/2001 | 13 | 4  | 9  | 5  | 2  | 3  | 15 |
| 29/03/2001 | 10      | 6  | 4   | 5  | 4  | 1   | 11         | 03/04/2001 | 17 | 4   | 13    | 3  | 1  | 2  | 17         | 03/04/2001 | 25  | 6  | 19 | 7  | 4  | 3          | 26         | 03/04/2001 | 21 | 8  | 13 | 4  | 2  | 2  | 22 |
| 03/04/2001 | 16      | 4  | 12  | 3  | 0  | 3   | 19         | 04/04/2001 | 18 | 7   | 11    | 2  | 1  | 1  | 18         | 04/04/2001 | 14  | 4  | 10 | 4  | 1  | 3          | 15         | 04/04/2001 | 10 | 3  | 7  | 1  | 1  | 0  | 10 |
| 04/04/2001 | 18      | 5  | 13  | 3  | 1  | 2   | 15         | 19/04/2001 | 10 | 2   | 8     | 1  | 1  | 0  | 11         | 19/04/2001 | 21  | 7  | 14 | 6  | 4  | 2          | 22         | 19/04/2001 | 14 | 2  | 12 | 0  | 0  | 0  | 14 |
| 19/04/2001 | 22      | 5  | 17  | 2  | 2  | 0   | 20         | 20/04/2001 | 19 | 4   | 15    | 3  | 3  | 0  | 20         | 20/04/2001 | 13  | 3  | 10 | 1  | 1  | 0          | 13         | 20/04/2001 | 19 | 8  | 11 | 0  | 0  | 0  | 19 |
| 20/04/2001 | 14      | 3  | 11  | 0  | 0  | 0   | 14         | 08/05/2001 | 15 | 5   | 10    | 4  | 2  | 2  | 14         | 08/05/2001 | 19  | 4  | 15 | 4  | 3  | 1          | 21         | 08/05/2001 | 17 | 2  | 15 | 2  | 2  | 0  | 18 |
| 08/05/2001 | 21      | 7  | 14  | 2  | 0  | 2   | 23         | 10/05/2001 | 19 | 9   | 10    | 2  | 1  | 1  | 19         | 10/05/2001 | 22  | 7  | 15 | 3  | 2  | 1          | 23         | 10/05/2001 | 20 | 5  | 15 | 0  | 0  | 0  | 20 |
| 10/05/2001 | 26      | 5  | 21  | 1  | 1  | 0   | 26         | 11/05/2001 | 24 | 5   | 19    | 3  | 1  | 2  | 25         | 11/05/2001 | 27  | 6  | 21 | 2  | 2  | 0          | 27         | 11/05/2001 | 25 | 6  | 19 | 3  | 2  | 1  | 26 |
| 11/05/2001 | 25      | 7  | 18  | 0  | 0  | 0   | 25         | 14/05/2001 | 29 | 6   | 23    | 2  | 2  | 0  | 30         | 14/05/2001 | 28  | 4  | 24 | 2  | 1  | 1          | 28         | 14/05/2001 | 27 | 4  | 23 | 1  | 0  | 27 | 0  |
| 14/05/2001 | 18      | 8  | 10  | 0  | 0  | 0   | 18         | 15/05/2001 | 17 | 8   | 9     | 0  | 0  | 0  | 17         | 15/05/2001 | 19  | 2  | 17 | 1  | 1  | 0          | 19         | 15/05/2001 | 16 | 5  | 11 | 1  | 0  | 1  | 17 |
| 15/05/2001 | 34      | 6  | 28  | 3  | 2  | 1   | 35         | 16/05/2001 | 36 | 9   | 27    | 4  | 1  | 3  | 36         | 16/05/2001 | 37  | 7  | 30 | 1  | 0  | 1          | 38         | 16/05/2001 | 35 | 10 | 25 | 2  | 2  | 0  | 35 |



period in the training of all four dogs, although the problems requiring addressing and the amount of intervention were not the same for each dog. It was after seven weeks that the data from all dogs began to move consistently towards the training objective.

As the dogs progressed through the training programme, the proportion of trials in which no target was presented increased due to the background strategy of variable interval reinforcement for targets. The opportunity for doing Fa was always high throughout the training (there were 11 or 12 non-target filters available on every trial). However, the opportunity for doing Fm declined from an average rate of about one target every two trials to one target every four trials. Thus, by the end of the training programme, the opportunity to do Fm was rare. The few mistakes made at the end of training were about equally distributed between Fa and Fm (Fig. 3), indicating that the occurrence of false indications (a training problem) was negligible. The background strategy of progressively lowering the detection threshold for TNT was the cause of the increasing tendency to make Fm mistakes throughout the training programme by all dogs (most obvious in the Fig. 3 results for Sam and Hindi). Thus, the very low proportion of mistakes at the end of the training period were established despite a much lowered threshold of detection for TNT relative to the beginning of training.

### *Maintenance training and operational use*

Maintenance training involves ensuring that previously trained skills are not lost by the dog. An acceptable standard of performance has been reached for a task. There is now a need to maintain that skill at the standard. That maintenance programme must operate in the background of any other training that the dog experiences.

Experience from previous projects at NOKSH AS with sniffer dogs indicates that search behaviour should be maintained in the background of all other training objectives. That maintenance may include extending the search response of the dog. As a general principle, any training situation in which a response is being reinforced continuously should be avoided. Overall, the trainer should organise the training programme around the two general principles that: i) previously established behaviours must continue to be trained, and ii) that any new training objective must not interfere with the maintenance of a previously established objective.

If a dog should indicate a filter cartridge when analysing unknown material, then the set procedure will be to lead the dog away from the positive box/filter cartridge after indication. If a variable pattern of reinforcement was used during the original training, then the operational dog will have no expectation that any particular indication will produce a reward. The dog must be able to indicate a positive box correctly and at the same time have a low error frequency (stage 1) before any changes are made to the pattern of reinforcement.

### *Procedures for testing unknown filters*

Testing of unknown filters involved three persons with set tasks and responsibilities:

- *Dog handler.* The dog handler leads the dog in and out of the room, is responsible for making sure that the dog investigates all filter cartridges and reports any finds. Positive finds are reported on a form and handed over to the person responsible for preparing the filter cartridges for analysis (filter supervisor).

When the dog indicates a filter cartridge, the dog handler leads the dog away from the site and out of the room without any reinforcer.

- *Test leader.* The test leader coordinates the analysis. This person notifies the dog handler when the trial can be carried out, is responsible for the assessment of the dog by reporting results to the filter supervisor, and records other responses and enters these in a training journal for each dog.
- *Filter supervisor.* This person determines which filters are to be placed in the apparatus and keeps records about placement and presentation rate of positive filter cartridges using reports from the dog handler and test leader. The filter supervisor is not present when the dog performs the trial. The filter supervisor prepares the trial site with new sets of filter cartridges (all 12 are changed at once) and also ensures that any positive/suspect filter cartridges are investigated by several dogs.

Each set of filter cartridges is investigated by at least three dogs. Each dog investigates one set (12) of filter cartridges twice. Between each search performed by the dog, the positions of the filter cartridges are rotated on the ADSM. If the dog indicates a positive filter cartridge, then the dog leaves the room and the position on the apparatus is changed. The dog then searches again. If it again indicates the positive filter cartridge, then the indicated filter cartridge is removed and replaced. Dogs no. 2 and 3 investigate the other filter cartridges in the absence of the positive filter cartridge.

The filter supervisor is responsible for new checks of filter cartridges that have previously been indicated as positive/suspect. The filter cartridges are inserted in a new series with which the test leader and dog handler are not familiar.

## Analysis and discussion

The main role of the REST system is to identify negative filter cartridges (i.e. with no trace of mines/UXO) in an area reduction role. If the dog is able, simultaneously and to a satisfactory degree of reliability, to indicate positive filter cartridges (those with a trace of mines/UXO), then the system has the dual role of both area reduction, and identification of areas requiring clearance. In low-density minefields, the system is extremely cost-effective compared with other methods. In areas with a high density of mines and/or a known boundary, the REST system will not be appropriate for use.

Initially, the REST system was developed as a system for detection of weapons and explosives. Air samples were taken from sealed compartments on train carriages, lorries and other vehicles. The equipment used for sampling and other parts of the analysis process were simple and designed with the fieldwork in mind. Conditions for detection were optimal in that samples were taken from sealed compartments often at high temperatures. Development of the system for mine detection involved solving the two requirements of a lower detection threshold, and the difficulty of obtaining samples. After relatively few years of testing in the field, the REST system was transferred to NPA to be used as a field operational system similar to the one Mechem had used in Mozambique.

Equipment and instructors were originally sent from Mechem to NPA, but the two organisations have developed the system in different directions. Many similarities remain, but there are significant contrasts in the practices of both dog training and the execution of the analysis process. NPA has consistently used the system in the field.

Limited supply of resources has forced them in the direction of simple solutions. Mechem, on the other hand, have developed a system with a higher degree of control over conditions for both dog training and analysis.

NOKSH AS duplicated the REST system currently practiced by Mechem for its projects in order to provide the quantified analysis of training results above (which is not available from Mechem). Results have more or less concurred with results reported by Mechem, but experience gathered from the training of four dogs suggests several options for increasing the efficiency of training, maintenance and practical analysis. The following comments are not intended as criticism of the REST system as it is currently used by other agencies, but could be used to make the system more credible and effective.

### *Sampling*

If sampling is to be carried out efficiently and justifiably, then a good log and backup system is essential. A review of the procedures for sampling in the SOP for Mechem and NPA indicates that procedures are used to ensure that each filter cartridge can be traced back accurately to the sampling location. GPS is used to record the start/finish positions and change of filter cartridges. NPA also records various physical data (temperature, wind, humidity, etc), but the data is mainly described subjectively rather than quantitatively. For calibration of the air volume (kp/min) sucked through each filter, a hand-held manometer is used at the start and occasionally during the sampling process.

Studies indicate that variation in temperature/humidity and soil moisture results in considerable variation in concentrations of TNT and other molecules in the air over a mine, with both short- and long-term effects. Concentrations of these trace substances bound to the soil and dust are much higher than are available as free molecules in the air over the same mine (Phelan and Barnett, 2001; Webb and Phelan, 2000).

To identify optimal conditions for sampling, it is therefore essential to gather as much physical data on each sample as practically possible. It should be possible to set up systems for continuous measurement of humidity and temperature, where the data is linked to each filter cartridge. Also, a manometer should be fitted to the vacuum pump so that the air-flow through each filter is monitored continuously, ensuring that the operator can replace filters if they become clogged.

Manual sampling is the most critical aspect of the REST system. One possible perspective in this context could be a connection between the actual sampling team and satellite navigation (e.g. as described in the magazine *GPS World*, 2000/2001). Systems for continuous satellite navigation of boats and vehicles have already been developed. By connecting this type of navigation with an electronic map, movements made by the sampling team would be constantly recorded and could function as documentation of the extent to which a road or terrain has been covered.

### *Filter cartridges*

Filters are central to the REST method. An increasing amount of information indicates that dust and soil particles sucked into the filter cartridge when sampling will improve detection capability. The concentration of TNT and other scent substances bound to soil particles on the surface has been measured at 1 million times higher than for free

molecules in air directly above the surface (J. Phelan, Sandia National Laboratories, pers. comm.). There is therefore potential for improved detection if soil particles are sucked in along with the air into the filter cartridges. However, challenges are raised with regards to design/construction of filter cartridges and requirements for sampling. There has been no systematic study of the degree of influence soil particles have on detection with the REST system, and NOKSH AS believes that such a study is essential before any work with filters and sampling procedures should proceed.

The availability of TNT bound to soil particles in the surface over a mine implies several hypotheses regarding disengagement of molecules for detection. Supply of moist air may be one reason for TNT molecules being released from soil particles. Dry dust/soil particles have a high affinity with water. Changing humidity could therefore release the bound TNT molecules for entry to either a dog's nose or a suction device. During searching, it is possible that the dog's sniffing increases humidity immediately in front of the nose, potentially increasing the availability of TNT molecules in the vapour drawn back into the nose. Humidity is also known to affect the concentration of TNT around the filter itself (Phelan and Barnett, 2001).

If a sampling procedure is to sample scent substances reliably from a mine while sucking up soil particles, then it is probable that the existing filter system should be modified. Also, there may be climatic restrictions on the use of the REST system. Areas where there is little loose material (e.g. soil is compacted or covered in vegetation) could result in reduced potential for transport of TNT and other substances. REST is being tested by NPA in Bosnia and Herzegovina with this possible restriction in mind.

### Transporting filter cartridges

Procedures for registration and transport of filter cartridges from sampling to analysis sites are, according to the Mechem and NPA-Angola SOPs, undertaken quickly. During transport, it is ensured that the containers with the filter cartridges are not stored or carried together with explosives or other materials that may cause contamination. It is also ensured that the filter cartridges are stored in a dark place with low humidity.

The Weapons and Protection Division, Swedish Defence Research Agency (FOI) in Sweden (pers. comm.), have suggested that these procedures are insufficient for optimal storage of traces of TNT in filter cartridges. They suggest that if concentrations of explosives (TNT etc.) are to be maintained during transport, it is necessary to cool the filter cartridges immediately after sampling. The cartridges are kept at low temperatures until they are to be analysed.

J. Phelan (pers. comm.) agrees because of the potential for biological activity causing breakdown of the target molecules (TNT, DNT) under humid conditions. He further noted that this problem does not apply to dry samples, and it may only be samples from wet conditions that need to be frozen (or air-dried). The reality is these comments are based on experience with soil samples rather than filter samples, and the effects of humidity on moist filter samples is unknown. Mechem does not believe that storage and transport at low temperatures would help improve the results of filter cartridge analysis. The typical conditions faced by these agencies when sampling in the field mean that storage and transport of samples in environmentally controlled conditions (such as a portable freezer) is certainly impractical and probably impossible.

## *Training of REST dogs*

### *Selecting dogs*

From the information gathered from Mechem and NPA, there is nothing to suggest that certain dog breeds are more suitable than others for training with the REST system. However, it is the case that only a limited number of dog breeds have been used, and these have usually been selected from the most traditional (German shepherd, Labrador retriever and Malinois). NOKSH AS used three English springer spaniels and a crossbreed (Labrador/springer) to test Mechem's methods, but that choice does not exclude other breeds (see GICHD, 2001, for a detailed analysis of breed issues).

There is a strong concurrence between the three organizations on the qualities required in dogs for training. Dogs must display a high degree of intensity to reinforcers such as a ball or kong. They must be able to maintain a high level of activity (search) over time, and must not be easily distracted by elements in their surroundings. Both sexes can be used, but bitches should be sterilised first (although the reasons for this requirement may be more to do with management than skills as a REST dog). It has been suggested, but not conclusively demonstrated, that the threshold for detection may vary for bitches in heat (Parlee, 1983). Of course, sterilisation of bitches represents a significant cost to the possibility of breeding from a dog found to be unusually good.

### *Variation in method*

For dog training, both NPA and Mechem make use of methodical principles based on forward chaining (Chapter 1, Part 2). The training procedures used by the two organisations appear to vary, but the methods are more or less the same. The level of difficulty increases through the various stages, while prompts are used to assist the dog when it has difficulties. Examples are the use of a signal (command) to train indication, or a leash to control the dog's movements. Such prompts can provide quick solutions to difficult problems, but are likely to slow the training process in the long-term and can even result in dependency (Catania, 1992; Bandura, 1986; Svartdal and Flaten, 1998). The NOKSH view is that independence of action by the dogs will give the most effective dogs for REST analysis. The dog must additionally display resistance to external influences. If the training is based on handler dependence and contains use of many different prompts, then exactly the opposite is achieved — the dog's independence is broken down and its consequent operational reliance on the handler is a significant disadvantage.

The NOKSH AS training style involved using reinforcers to create independent dogs that developed skills with a minimum of help. We ensured that the process does not rely on any given person or situation. In effect, the dog controlled the presentation of reinforcers through independent action, and by searching for and offering the action that the trainer was aiming to reinforce. The timing for presentation of reinforcement of a trained action was controlled precisely using a whistle or "clicker". The dog's perception of the clicker as being rewarding was maintained using an intermittent reinforcement process through occasionally giving a titbit, ball, kong, etc. The entire process can be controlled by an instructor/trainer, even at some distance, allowing training of new handlers during the transfer process (Chapter 1, Part 2).



When teaching a dog to indicate (sit), we used the same process, where the dog's natural behaviour helped reinforce the response. Reinforcers were given every time the dog sat spontaneously (without help, and in any situation), leading the dog to sit more frequently in any situation where it expected reinforcement. When the dog is then put in a situation where it has to find a desired action, sitting (indicating) will be a natural action to offer.

It has been suggested that this training method will lead to an increased frequency of incorrect indications, but our results do not support that suggestion. Rather, the training method results in a spontaneous action (sitting) which was easily reinforced under stimulus discrimination learning conditions.

Training which uses reinforcement of spontaneous responses and stimuli (whistle or clicker) as aids is intended to reduce dependency and ensure transferral and generalisation of skills (termed *response generalisation*). In many ways, this is the opposite of training methods where the same training stimuli are required to successfully transfer and generalise (termed *stimulus generalisation*). Development of responses based on forward chaining (as used by, e.g., Mechem) is a form of training requiring considerable stimulus generalisation when skills are to be transferred. Systematic work with response generalisation from the start makes the dogs much less reliant on environment, situation, time and person to complete their work and show adequate responses.

### Approaches to lowering odour thresholds of dogs

Training designed to establish search behaviour, indication behaviour and odour discrimination of TNT (TNT vapour strips), is presented here under the collective title "Explosive Odour Imprinting". Even though we describe three different training methods (NPA/Mechem/NOKSH), it appears that the dogs' skills are practically the same at the end of the imprinting process. Training by these organisations after imprinting is divided into stages and varies in both content, progress and skill requirements. Mechem/NOKSH use approximately the same training procedures after imprinting, whereas NPA's REST project in Angola uses a different procedure.

In the Mechem/NOKSH method description, the focus for progress is placed on lowering detection thresholds. By using vapour strips in cardboard boxes and sampling filter cartridges from these, extremely low concentrations of TNT are produced. Mechem claims that dogs, once they have completed the training, can detect traces from mines exclusively on the basis of available traces from remaining TNT. They believe that dogs trained in this way can detect positive filter cartridges irrespective of which area or scenario they come from.

NPA chose to teach dogs to detect five different trace substances. The choice of explosive substances was made on the basis of the types of explosive found in Angola. Vapour strips with scent substances from all the relevant types of explosive are produced and used in the training of dogs, just as with TNT. Then vapour strips are removed from the filter cartridges and all subsequent samples used for training are produced by direct sampling in the field. Initially the samples for training are taken from pure explosive substances, while later the samples are taken from genuine mines. This training helps the dogs establish discrimination based on a mixture of several (many) trace substances, but with less requirement to detect any one of these substances



at very low concentrations. Contrary to Mechem's dogs, NPA's dogs are dependent on training with a sample material taken from the actual area or scenario where the genuine samples are taken. Any move to new areas/territory where other mines are used will therefore entail an adjustment for the dogs and possibly a new round of imprinting on other types of explosives before the dogs can perform analysis.

Currently, there has been no comparative study of the two methods. It is possible that both methods detect positive filter cartridges with a similar degree of precision, but that differences in the basic training form skills whereby the dogs make use of varying detection strategies. Studies indicate that dogs detect scent substances consisting of many different substances (mixture of many molecules = bouquet) at a higher rate than single substances (one or a few molecules) (K.B. Døving, pers. comm). At NPA, the detection of complex substances is most probably the principal factor behind their successful detection of positive filter cartridges. At Mechem, it is the very low threshold of detection of TNT molecules that creates success.

It is important to strategically adjust the types of filter cartridge used *from the earliest stages of training*. Experience of training carried out at NOKSH AS (and probably by the other organisations) has shown that dogs can be accidentally trained to discriminate substances other than target odour substances. For example, if a pattern develops where one filter cartridge is essentially different from the others, that difference may result in a learned discrimination. The difference does not necessarily have to be connected to a certain odour substance, but just that the filter cartridge in one way or another is different from the others. It is therefore essential to establish routines for training and maintenance in which a minimum of two to four new filters are replaced regularly during the training process.

### *Assessment during training*

To achieve satisfactory quality assurance of dog training, it is essential to establish a continuous assessment process. Although they keep records, Mechem and NPA do not appear to assess training on a daily basis using objective procedures. Mechem spends some time testing dogs/handlers, and uses the results to determine any progress made in training. These tests, however, provide no information on variation in responses and are therefore unsuitable as a feedback tool allowing response to current difficulties that the dog may be experiencing. Any adjustments to training depend on the individual trainer/instructor's experience.

With NPA's training system, detailed records of the training process are made daily, but resources for analysis of that information are not available, again resulting in any adjustments to training depending on the individual trainer/instructor's experience.

A systematic assessment process is not only an important tool for training, but also forms a tool for control and quality assurance when assessing the individual dog's skills. A training journal can be presented prior to licencing or any other form of operational use of the dog. These journals document the individual dog's skills, and provide a baseline against which the ongoing use of the dog can be compared. The form for recording training results — illustrated in Annex 2, Fig. 3 — is an example of such a journal. This form can be further developed and used to record analysis results. Continual and accurate evaluation of all available material on the dogs also provides useful information for those responsible within each organisation.

With the REST system, there is not only a requirement for documentation of analysis results, but also for a legitimisation of the training received by each dog. Co-ordinated and uniform reports can contribute to a higher degree of numerical material, enabling quick preparation of documentation.

### *Maintenance*

Once the behaviours required of a REST dog are established and the dog has become operational, the question of how to maintain or even continue to improve those skills will use the same principles as have been described here for the original training programme for the dog. REST dogs may be handed over to local handlers, but in most cases they are worked at a base where experienced trainers continue to be on hand to supervise the ongoing maintenance training of the dog. Thus maintenance training of a REST dog is potentially a more straightforward issue than maintenance of field MDDs, which tend to work for long periods in isolated places.

### *The operational analysis of filters*

Mechem and NPA have both selected an analysis set-up where the stands with filter cartridges are arranged in a straight line. NPA uses a total of six stands with two filter cartridges each. Mechem uses 10-12 stands with one filter cartridge each. NPA sends dogs on free-running searches, forwards and backwards once, while Mechem leads dogs from stand to stand on a leash.

Research has shown that animals are capable of establishing structural maps of a training/test situation (Olton and Samuelson, 1976; Olton, 1983) and will make use of these in order to obtain reinforcement. Thus the organisation of the analysis process with all its procedures must be closely evaluated and continuously assessed in order to detect any errors that might influence the results. Both Mechem and NPA have displayed insight and comprehension of this problem, and reports compiled by NOKSH AS indicate that the organisations are constantly working to counteract any possible sources of error in their own procedures.

At both Mechem and NPA, training and analysis are carried out with active participation by dog handlers and assistants (trainers/assistants). Close cooperation is emphasised for satisfactory training and analysis procedures. At the same time, the organisations aim to train the dogs to display independent behaviour when analysing genuine material, and to ensure that the dogs' responses are exclusively triggered by discriminative scent stimuli, without any form of influence from other environmental factors.

Experience gathered by NOKSH AS during work with different types of sniffer dogs shows that changes to the methods and procedures for training can help reduce the requirement for contact between the dog and dog handler, without affecting skills and results. Similar experience has been gained when training and using sniffer dogs for narcotics in New York, USA (P. Waggener, Auburn University, pers. comm.).

The NOKSH AS model for training and analysis has been specifically designed to reduce the effects of environmental factors. The ADSM is circular and can be rotated so that it is impossible to use it as a reference to find a certain position without using the scent of smell. Reinforcements are controlled by conditioned signals (whistle or clicker) and the trainer/assistant uses a one-way window or mirror to avoid

unconsciously influencing the process. Training is executed without any bonds forming between the trainer and dog, sometimes by using more than one trainer for a dog.

NOKSH AS feels that it is important and necessary to continue testing both apparatus and training principles in order to further develop the REST system. Efficiency will only be improved if people are willing to query their own methods via a continual process of testing new effects.

If the REST system is to be further developed, then work on documentation must be continued. Mechem and NPA both document the training experiences, but there is room for improvement, most specifically in relation to the use of that information on a daily and weekly basis in order to adjust the training programme to the needs of each dog.

### *Further development of REST*

There is significant potential for development with the REST system, but there remains a number of areas which need to be tested before the system can be put to its full use. Studies currently in process will provide new results and a clearer picture of things. The REST system is being monitored by Sandia National Laboratory, U.S., and FOI in Sweden (earth and filter studies) — GICHD sub-study IVB, and NPA Angola (area reduction project) — GICHD sub-study IVC. However, if the necessary level of quality assurance is to be achieved with REST, then other areas must also be examined. There is a particular need for practical tests in the field, and experimental studies.

The following areas are those we suggest require examination:

- *Sampling:*  
Further testing of sampling procedures linking documentable parameters regarding position of the filter and physical conditions at the time of sampling (temperature, humidity, air-flow through filter) to each sample/set of samples.
- *Transport:*  
Ensure optimal conditions for each sample with regards to storing of existing trace substances. Quality-assure procedures for transport and storage until the analysis process can take place.
- *Dogs and dog handlers/trainers:*  
Select dogs with the best qualifications for the REST system. Trainers and dog handlers need a basic understanding of the psychology of learning, with a focus on training methods that teach dogs to act independently. Training should also be given in techniques for reporting behavioural parameters, in order to ensure quality assurance of training and maintenance of trained dogs.
- *Dog training - Standardised procedures for training:*  
To date there is no clear decision on which scent substance(s) should be used for "Explosive Odour Imprinting". Should the REST dogs be trained to detect TNT only, or would it be more advantageous to base training on a combination of scent substances (traces of various types of explosive)? A study currently proposed by NPA Bosnia will help to address this question.

- *Operational analysis:*  
Further develop test procedures and assess the best method of analysing samples with regards to environment (in field or in laboratory) and physical conditions experienced by the dogs during operational testing.

---

## Acknowledgements

This paper has benefited from discussions with a wide range of people, including the members of the Mine Dog Standards Advisory Group, delegates at the Mine Detection Dog meetings in Ljubljana (Slovenia) in 1999, and San Antonio (Texas) in 2000, and many others with an interest in dogs. The time spent visiting various organisations provided much useful information for work on this report. NOKSH especially thanks B. Lewis (NPA, Angola) and K. Shultz, T.v. Dyke and V. Joynt (Mechem, South Africa). Our work has been carried out in close dialogue with members of the GICHD study group, with special thanks to H. Bach for his trust in the skills of NOKSH AS, and to I. McLean for his technical contributions and linguistic assistance when writing the report. Finally, special thanks to colleagues in NOKSH AS (T.H. Eiken, P.J. Matre) and the staff of FDTA (E.K. Andersen, M.B. Iden), who made essential contributions to the training of the four REST dogs.

---

## References

- Bandura, A (1986)  
*Social Foundation of Thought and Action, A Social Cognitive Theory*, Prentice Hall, London.
- Catania, C. (1992)  
*Learning*, Prentice Hall, New York.
- Fjellanger, R., E.K. Andersen and I.G. McLean (in press)  
“A training program for filter-search mine detection dogs”, *International Journal of Comparative Psychology*, available at [www.gichd.ch/pdf/Research/McLean\\_REST\\_dogs\\_1.pdf](http://www.gichd.ch/pdf/Research/McLean_REST_dogs_1.pdf)
- GICHD (2001)  
*Designer Dogs: improving the quality of mine detection dogs*, GICHD, Geneva.
- Olton, D. S. (1983)  
*Memory Function and the Hippocampus*, The Johns Hopkins University, Baltimore, Maryland, U.S.
- Olton, D. S., and R. J. Samuelson (1976)  
“Remembrance of places passed: Spatial memory in rats”, *Journal of Experimental Psychology: Animal Behaviour Processes* 2:97-116.
- Parlee, M. B. (1983)  
“Menstrual Rhythms in Sensory Processes: A Review of Fluctuations in Vision, Olfaction, Audition, Taste and Touch”, *Psychological Bulletin* 93:539-548.
- Phelan, J.M., and J.L. Barnett (2001)  
*Phase Partitioning of TNT and DNT in Soils*, Sandia National Laboratories Report SAND 2001-0310, Albuquerque, New Mexico, February.
- Svartdal, F., and M. A. Flaten (1998)  
*Læringspsykologi*, Ad Notam Gyldendal.
- Webb, S. W., and J. M. Phelan (2000)  
*Effect of Diurnal and Seasonal Weather Variations on the Chemical Signatures from Buried Landmines/UXO*, Proceedings of Conference on Detection and Remediation Technologies for Mines and Minelike Targets V, 24-28 April 2000.

## Annex 1

# Equipment requirements in training of REST detection dogs

The three methods of training involve various equipment requirements. Limited resources and local conditions have had an influence on the methods chosen. For example, it is difficult to get hold of the right size and number of cardboard boxes in Angola. Other solutions have therefore to be found so that training can be carried out with satisfactory results.

### *Sampling for training*

For sampling for training, standardised procedures are required in order to procure filter cartridges for training. Each filter cartridge is produced according to detailed specifications, providing the required concentration of scent substance — an essential element for training. The concentration of molecules is a known factor, or can be calculated based on the compound of the substance and the material's evaporation pressure. Samples are produced with increasingly low concentrations, so that during training the dog will become more sensitive and able to detect very low volumes of trace substances.

### *Vapour strips – positives and negatives*

The source of TNT molecules (2,4,6-Trinitrotoluene) is the so-called vapour strips, produced by Mechem, South Africa. The vapour strips are produced by placing Whatman filter paper (57 x 46 cm) in a solution of TNT dissolved in acetone. The TNT used is as pure as possible. The filter paper is then removed and dried before being cut into strips of 57 x 23 cm.

Negative vapour strips are produced in the same way. The same type of paper and solvent (acetone) is used, but without the TNT. Negative strips are required to train the dog to discriminate background scents (acetone and paper) from the scent substance, TNT. Negative strips are used in training as early as possible and as often as possible in order to reduce the risk of the scent of the strips becoming a discriminatory stimulus for the dog during analysis.

### *The filter*

The filters developed for this process are made of hard plastic, shaped like cylinders (54 mm long) and with an external diameter of 25 mm. Inside the cylinder is a central core (also of hard plastic) and around this is a netting canvas of polyvinyl chloride (PVC). The hard, central core holds the PVC canvas in place so that around 20 mm of the canvas sticks out at one end and is flush with the cylinder at the other end. The PVC canvas is specially designed to easily absorb TNT molecules. Each filter is packed in a sealed plastic container. After a sample has been taken, the filter is returned to the same container and not reopened until the analysis process.



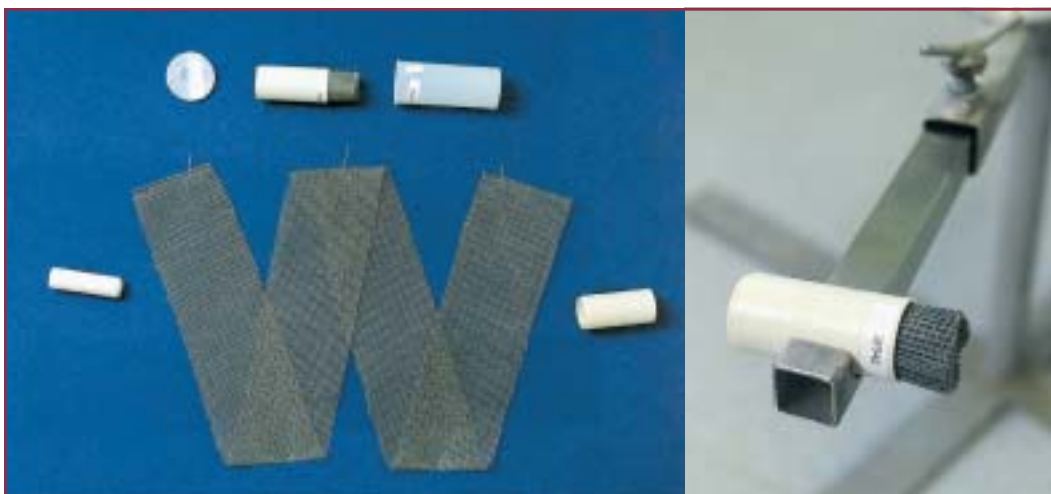

### *REST backpack – the scent trapping equipment*

This is a person-portable, petrol-driven unit designed to provide air suction. The machine (a Husqvarna RBD – 240) consists of a small two-stroke engine connected to an impeller type suction unit (Electrolux) by means of a flat belt. This is an air-cooled, two-stroke motor with a centrifugal clutch. It has a built-in fuel tank and the throttle control has been modified to operate at a chosen RPM. The unit is mounted on a backpack frame and connected to the sampling head by means of a flexible hose. The suction tube has a double-filter cartridge assembly at the long end, which accommodates two filter cartridges. The sampling kit normally consists of the sampling machines with machine accessories/spares (air filters, oil/fuel cans, extra flexible pipes, grease and tools).

### *Cardboard boxes*

Boxes of different sizes are used as insulated cavities for the evaporation of TNT at controlled volumes. Positive strips are placed in the box, and after a set time, gas samples are taken by suction from the box using a vacuum pump (vacuum cleaner). The time the strips are left in the box and the suction time are both parameters which can be varied. The boxes are also used in a similar way to produce negative strips, so that filter cartridges without TNT molecules can be produced by the same method. The boxes are also used to produce various types of background scent (oil products, cigarettes, food, plastic gloves, various kinds of waste etc.).

### *The stand*

The stand is a T-shaped frame which allows it to stand alone on a flat surface. The construction is made of stainless steel and is used as a grip for filter cartridges while training and analysing. The number of grips can vary. Mechem uses stands with one grip, where the filter cartridge is maintained horizontally. NPA use two grips for their stands, and both filter cartridges are placed vertically.



### *ADSM (Apparatus for Discrimination of Source Material)*

The ADSM is a circular stand to which 1-12 arms are connected. The stand has a base which allows it to stand alone on a flat surface. An axle is fitted from the base up to the connections for the arms, which can be rotated separately from the base. The number of arms on the stand is determined by the individual training situation. The arms connected to the stand are of stainless steel, and have fittings for boxes or filter cartridges.





Figure 2  
From Standard Operating Procedures, Norwegian People's Aid, Angola

| REST ANALYSIS SHEET |  |                  |  |              |       |
|---------------------|--|------------------|--|--------------|-------|
| Task code:          |  | Temp.:           |  | Responsible: |       |
| Box NR.:            |  | Wind dir./speed: |  | Sign:        |       |
| Sampling sheet NR.: |  | DTG start:       |  | Handlers:    |       |
| Analysis sheet NR.: |  | DTG finish:      |  |              |       |
| REST DOGS           |  |                  |  |              |       |
| Tube NR.            |  |                  |  |              | Notes |
| A 1                 |  |                  |  |              |       |
| A 2                 |  |                  |  |              |       |
| A 3                 |  |                  |  |              |       |
| A 4                 |  |                  |  |              |       |
| B 1                 |  |                  |  |              |       |
| B 2                 |  |                  |  |              |       |
| B 3                 |  |                  |  |              |       |
| B 4                 |  |                  |  |              |       |
| C 1                 |  |                  |  |              |       |
| C 2                 |  |                  |  |              |       |
| C 3                 |  |                  |  |              |       |
| C 4                 |  |                  |  |              |       |
| D 1                 |  |                  |  |              |       |
| D 2                 |  |                  |  |              |       |
| D 3                 |  |                  |  |              |       |
| D 4                 |  |                  |  |              |       |
| E 1                 |  |                  |  |              |       |
| E 2                 |  |                  |  |              |       |
| E 3                 |  |                  |  |              |       |
| E 4                 |  |                  |  |              |       |
| F 1                 |  |                  |  |              |       |
| F 2                 |  |                  |  |              |       |
| F 3                 |  |                  |  |              |       |
| F 4                 |  |                  |  |              |       |

Figure 3  
Assessment of dogs during training. NOKSH AS, Norway.

| Date                   | Time  | Temp: | Humidity: | Filter    |           | n  | Fa | Fm | Cr | Cht | F | Fa | Fm |
|------------------------|-------|-------|-----------|-----------|-----------|----|----|----|----|-----|---|----|----|
|                        |       |       |           | 1-section | 2-section |    |    |    |    |     |   |    |    |
| n =                    | __C=  | __Cr= | __F=      | __Fa=     | __Fm=     |    |    |    |    |     |   |    |    |
| n =                    | __C=  | __Cr= | __F=      | __Fa=     | __Fm=     |    |    |    |    |     |   |    |    |
| <b>POSITIVE FILTER</b> |       |       |           |           |           |    |    |    |    |     |   |    |    |
| 1                      | 2 3   | 4     | 5         | 6         | 7         | 8  | 9  | 10 |    |     |   |    |    |
| 12                     | 13 14 | 15    | 16        | 17        | 18        | 19 | 20 | 21 |    |     |   |    |    |
| 23                     | 24 25 | 26    | 27        | 28        | 29        | 30 | 31 | 32 |    |     |   |    |    |
| <b>Temp: Humidity:</b> |       |       |           |           |           |    |    |    |    |     |   |    |    |
| 1                      | 2 3   | 4     | 5         | 6         | 7         | 8  | 9  | 10 |    |     |   |    |    |
| 12                     | 13 14 | 15    | 16        | 17        | 18        | 19 | 20 | 21 |    |     |   |    |    |
| 23                     | 24 25 | 26    | 27        | 28        | 29        | 30 | 31 | 32 |    |     |   |    |    |

**raining journal**

A set record of responses or behaviours shall be kept for each time the dog enters the training room. Responses are recorded based on four criteria. Two records are kept of positive behaviour (C) (correct response) and two records are kept of negative behaviour (F) (false). Indication of the positive box/filter cartridge is recorded as Cr and search of exclusively negative boxes/filter cartridges without indicating is recorded as Cnt. If the dog should indicate a negative box/filter cartridge, this is recorded as Fa and if the dog should fail to indicate a positive box/filter cartridge, this is recorded as Fm. The total number of recorded responses (C + F) is n.





## Chapter 2

# Case studies on training mine detection dogs

### Part 3

# Training dogs to detect tripwires

*Dan Hayter*

**T**he proposed protocol for training dogs to detect tripwires contained in Annex 1 was developed and tested by the Global Training Academy during 2001 as part of the GICHD Tripwire Research Project.

## Tripwire protocol

### *Lessons learned*

It has been our experience that tripwire should be introduced to mine dogs near the end of their training course. Untrained or young dogs that are new to mine detection have a difficult task learning to sniff the ground to detect explosives and mines hidden below the surface. If a trainer rushes this protocol, trying to duplicate normal tripwire placements above the surface, young dogs have a tendency to concentrate their efforts on searching high and not sniffing the surface. The problems encountered are magnified when attempting to teach the dog(s) to detect deeply hidden mines.

*Note:* We have never used or relied upon our dogs as a primary detector of tripwires. Dogs were taught this task in order to become a more effective and safer detector in the minefields. A good handler can normally recognise a dog's alert on trip wires by his JND (Just Noticeable Difference) (see Chapter 1, Part 3).

### *Introduction of tripwires*

1. The scent of tripwire is normally introduced around the eighth to tenth week of training. We use the five-hole variable to introduce scent to our dogs. This involves placing the odour in the first hole of the five-hole placements (see picture below).
  - We normally use single 8 x 8 inch cinder blocks for the five-hole placements with the blocks spaced 4-6 feet apart so that the handler and dog can manoeuvre around the blocks while searching.

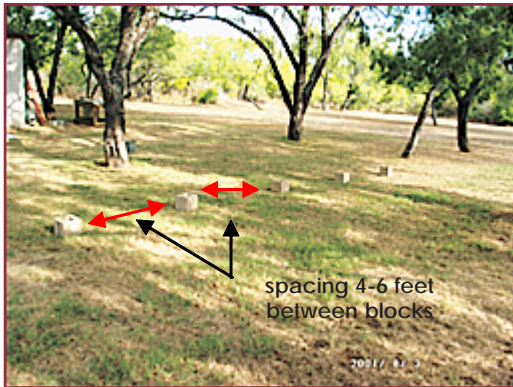

*Note: The spacing between blocks.*

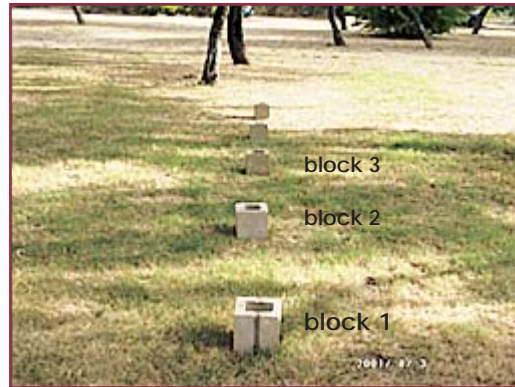

*Normal set up of five-hole variable.*

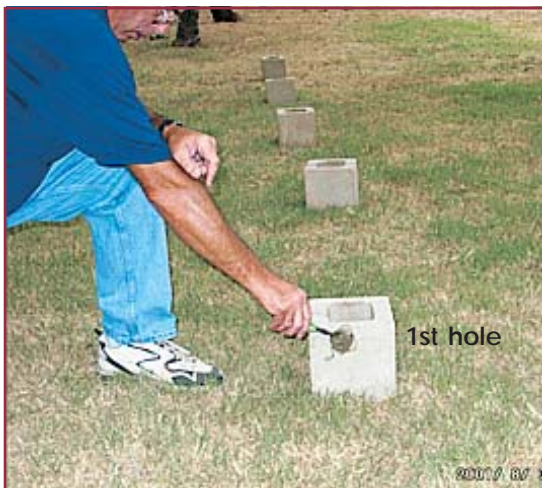

*Tripwire placement first hole.*



*Tripwire placement second hole.*

- The dog needs room to sit when detecting the odour.
- We start with the odour being hidden in the first hole of the placement. The handler will assist the dog in the beginning with a verbal cue of "Sit".



*Tripwire in hole (4-6 feet rolled up).*

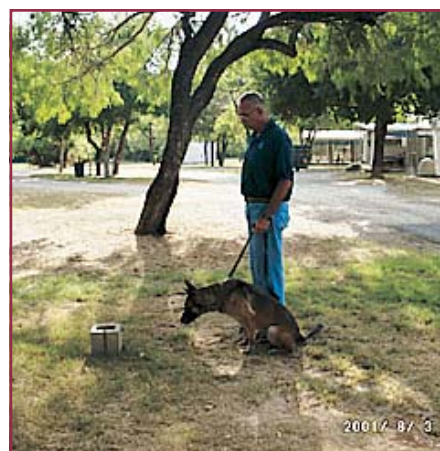

*Start position on five-hole variable.*





*Trainer presenting first hole for sniffing .*

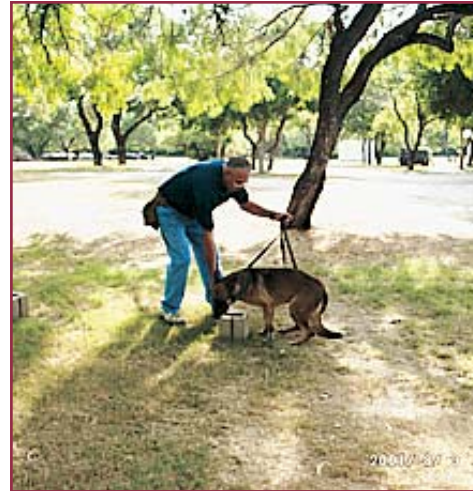

*Dog assisted into the Sit position.*



*Trainer continues to move to end of leash.*



*Commanded "Stay" until rewarded.*



*Dog is rewarded with Cressite ball.*

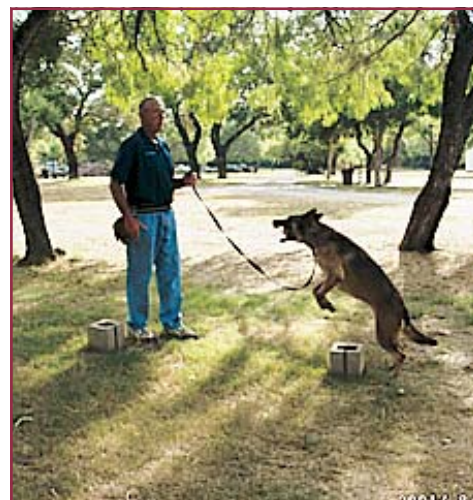

*Dog retrieves reward when thrown.*



- Once the dog is indicating the presence of the wire with positive responses in the first hole then it is moved to the second hole.
  - The task is repeated until the dog has found the wire in each hole successfully.
  - The wire is then randomly moved around in the five-hole placements until the dog has mastered the five-hole variable search sequence.
2. We use the Continuous Reward System (Chapter 1, Part 3) in mine dog training. A variable reward may be used but we do not recommend it due to the length of time in actual searches that a dog will work to find an actual mine.
  3. The introduction of tripwire odour takes only a couple of days. This is accomplished through the *positive transfer of learning*, which has taken place when introducing explosives and mine fragments as described in Chapter 1, Part 3.
  4. The next step in training is to place the tripwire along the search pattern that the dog works during detection training for mines.
    - We will normally place small rolls (5-8 feet) of tripwire out on the search path of the dog. Remember the dog has already completed the five-hole variable introduction to tripwire odour.



*Trail with tripwire laying on ground.*



*Placement of small roll tripwire.*

- When the dog crosses the wire and the trainer sees a JND he gives the command of "Sit". A positive response from the dog requires a primary reward being thrown towards the dog from the front.
- The reward is thrown slightly over his head and to the rear for a chase.



*Dog approaching tripwire location.*



*Dog assuming the Sit position.*





*Trainer gives command STAY and moves forward to reward the dog.*



*Dog is rewarded to the rear away from the tripwire.*

- Once the dog is responding consistently without trainer assistance where tripwire is laid along the search path, we then stretch the wire out on the ground usually 2-3 strands thick to increase the scent (vapour) to ensure easy detection.
- The strands of tripwire are gradually decreased (Chapter 1, Part 3; Successive approximation and shaping), as the dogs become more proficient.



*Three strands of tripwire laid on path.*



*Close-up of the three strands of tripwire.*



*Dog detects tripwire odour.*



*Trainer has the dog sniff the wire.*



*Trainer then rewards dog to the rear.*

5. The next step is to stretch the wire out, off to the side of the search path ensuring a crosswind is available. The wind should carry the scent of tripwire across the path. This process will teach the dog not to approach the tripwire.

- The wire is stretched out 2-4 inches above the ground for approximately 5-8 feet (1.5-2.5 metres). Again ensure the crosswind carries the scent of the wire across the search path.
- When the handler sees the JND, he commands the dog to “Sit” and “Stay”. Note: The use of prompt timing with the command “Sit and Reward” is most important.





*Tripwire laid in the grass along path.*



*Dog is searching with a crosswind.*



*Dog crosses path towards the wire.*



*Trainer approaches dog commands "Sit" and "Stay" and verbal praise.*



*Trainer returns to his search position and recalls dog for reward.*

- In the beginning exercises the handler or trainer approaches the dog holding the reward in his right hand and shows the dog the tripwire and reward together.
  - The dog is then verbally praised and the primary reward is thrown in back of the dog away from the wire.
  - This process takes 14-21 training days to teach the dog not to approach tripwires.
  - Once the dog learns the Sit response consistently the use of avoidance training techniques may be used in the training (Chapter 1, Part 3).
  - Avoidance training is used to ensure that the dog learns not to approach the tripwire after his JND. This usually amounts to the use of verbal or physical corrections.
5. The next step in training is introduced when the dog is responding with the Sit response and not approaching the tripwire. We then proceed to place the tripwire across the paths that the dog will cross in training.
- We also may begin to introduce fishing lines and other types of improvised tripwires that may be encountered in a real work scenario.
  - With the wire crossing the path of search with little wind or a crosswind it is quite common for the dog(s) to reach the wire and then back up before responding with the “Sit” response.
6. The next step in tripwire training is to introduce dangling tripwires. These wires can be attached high from a tree reaching the ground or dangling above the ground.
- We know from our tripwire research project and field experience that dogs use their olfactory capabilities as their primary detector.
  - We have also seen them use their sense of sight, hearing and touch to assist with detection.
  - Well-trained dogs often indicate the presence of tripwires when shadows or unexplained movement are noticed. The only drawback — if it can be called one — is that they may respond to vines or shadows of small sticks across the search surface.
7. In our chemical analysis of tripwires (see below) we found TNT, DNT and certain other chemicals to be present on military-type tripwire. The Tripwire Research Project has answered a lot of questions about the olfactory ability of the dogs to detect tripwire. Some of the tripwires we tested had been in minefields for as long as ten years before

we had them analysed. It was also evident that seasoned dogs used in the study, such as Rosa and Blanca, were much more capable of detecting tripwire than a young dog that was in training for only 6-8 months. Explanations include:

- The older dogs had refined their sense of smell.
- They had learned to detect anomalous odours, which do not belong in the setting.
- Years of actual work experience and training improved a dog's capability in any task it is trained for.

Progress reports from the study are provided as Annexes 2, 3 and 4.



## Annex 1

# Protocol for tripwire testing

### *Introduction*

Dogs are capable of discriminating a number of compounds constituting a complex odour picture. The purpose of this project is to determine the compound(s) dogs learn to use in detecting tripwires. Mine detection dogs are typically trained using tripwire that is being used in the actual mine fields. Experience has shown us that dogs primarily use their sense of smell in detection of tripwire but they will also use their senses of sight and hearing in detection.

### *Information*

1. The following MDD Tripwire Testing Protocol has been developed based upon Texas Research Institute (TRI) analysis of sample tripwires submitted by Global Training Academy. A copy of the TRI Laboratory Analysis Report is attached to this testing protocol procedure.
2. The dogs used for this project were selected using the same criteria, as would candidates for mine detection dogs. These dogs will be trained using a rubber ball or a kong as a reward for task accomplishment.
3. Ideally, a separate dog for each odour compound should have been used in the study, but limited funding has restricted the number of dogs. Global and TRI determined that a mixture of the odour components of: hexanal, ethylbenzene, xylene, decane, nonanal, undecane, and naphthalene would be used to make up the composite odour (simulated tripwire).
4. Global will train four dogs to do the following tasks:
  - Two dogs will be conditioned (trained) to detect the composite odours/simulated tripwire by scent and respond with a Sit.
  - One dog will be trained to detect mines and tripwires not using any of the data gathered from TRI.
  - One dog will be trained to detect mines only.

### *Procedure*

1. Using the five-hole Variable Training Protocol the composite odours will be introduced to each dog in a control laboratory environment. The training will be video taped randomly in the laboratory. The dogs will be required to discriminate the composite odour applied to a sterile gauze. The composite odour gauze is placed in a glass jar along with four similar jars with sterile gauze. The dog's final response upon detection of the composite odours/simulated tripwire is to Sit. Both dogs will be required to achieve a detection rate of 95 per cent.

2. The second step will be that both dogs discriminate the composite odour when placed among controlled samples (other odour samples). The goal is to obtain 95 per cent or higher accuracy in the laboratory.
3. The senior trainer and handler/trainer will record the following data:
  - Five-hole variable placement location of composite odour each time dog searches;
  - Positive and false responses by the dog;
  - Negative (misses) results by the dog;
  - Assisted (trainer using verbal or physical cues) responses;
  - Placement of controls when used in five-hole variable.
4. The first objective is to progress from detection of the composite odour (simulated tripwire odour) in the laboratory to determine if the dogs can detect the simulated tripwire odour in the outdoor environment. If the dog(s) need additional training to accomplish this task then the results will be documented as part of the Tripwire Testing/Training Protocol Study.
5. The second objective is to determine if the dogs trained on simulated tripwire odour can detect the presence of tripwire when placed in the outdoor environment. If either or both dogs encounter problems with this task it is important to document how much additional training time is required for the dogs to complete this portion of the test objective. It is also important that the training techniques used to accomplish this task are recorded.
6. The third objective is to determine if dogs trained in the laboratory have the ability to detect tripwire effectively, while working in similar search patterns to those of a mine detection dog. In this portion of the test Global will use two additional dogs:
  - One dog trained on mines and tripwire without the use of simulated tripwire odour (composite odour);
  - One dog trained only to detect mines;
  - Two dogs trained on simulated tripwire odour (additional dogs).
7. A controlled test site has been established with tripwires and mines. The mines and tripwire have been randomly placed throughout the site. We wish to gather data to aid us in determining how effective each dog would be in the minefield. We understand that each dog has had limited training to this point. The data will provide us needed information in developing a sound Training Tripwire Protocol — especially since we have identified that tripwire used in a minefield in the Balkans has TNT contamination.



## Annex 2

# Interim study report and summary of results, 10 July 2001

Global Training Academy has finished the Tripwire Research Project:

- Completed all dog training.
- Completed all research testing.
- Completed recording data and analysed the information.

1. The data gathered during training and testing indicates that mine dogs use their sense of smell and sight to detect tripwires. In all the test and training events, we never observed any of the six dogs used in this project to detect tripwires through audible means.

2. We learned early in the project from test results conducted by TRI (Texas Research Institute, Austin Inc.) using SPMR-GCMS (Gas Chromatography/Mass Spectrometry), that there are some distinct vapours (scents) associated with tripwires. With the assistance of TRI, Global Training Academy developed synthetic tripwire vapour using a chemical mixture from the most common compounds associated with the tested tripwire. In theory and on paper it looks good. The training protocol required that two dogs be trained in the laboratory using training aids made from the headspace extracted from the chemical compound. In the test portion of the project both dogs were unable to detect tripwires that were hidden in the test field.

3. A Test Evaluation Field was constructed on 24 and 25 January 2001. The test site consisted of six 10 x 10 yards (9 x 9 metre) plots containing tripwires and mines.

- Site #1 contained two tripwires (first wire metal surface laid 9 feet long. The second plastic coated wire 10 feet long surface laid) and a part of a PMN with 1 ounce (14 gm) of TNT (1 foot = 30 cm).
- Site #2 contained two tripwires (first wire was bare wire 2 feet long and the second was plastic covered 6 feet long).
- Site #3 contained two tripwires (first wire was plastic coated wire 11 feet long surface laid and the second wire was plastic coated wire 9.5 feet long surface laid).
- Site #4 contained two tripwires and half an ounce TNT and mine fragmentation. (first wire was plastic coated 3 feet long, 5 inches off the surface and the second wire was 20 feet long from a height of 6 feet angled to the surface).
- Site #5 contained two tripwires and one ounce of TNT buried in a glass jar (first wire was 7 feet long, 3 inches off surface and the second wire was bare metal 12 feet long 6 inches high).
- Site #6 contained two tripwires (first wire was 6 feet long plastic covered and the second wire was 13 feet long and was bare metal; both wires were surface laid).

Below is a sketch map of the test site.

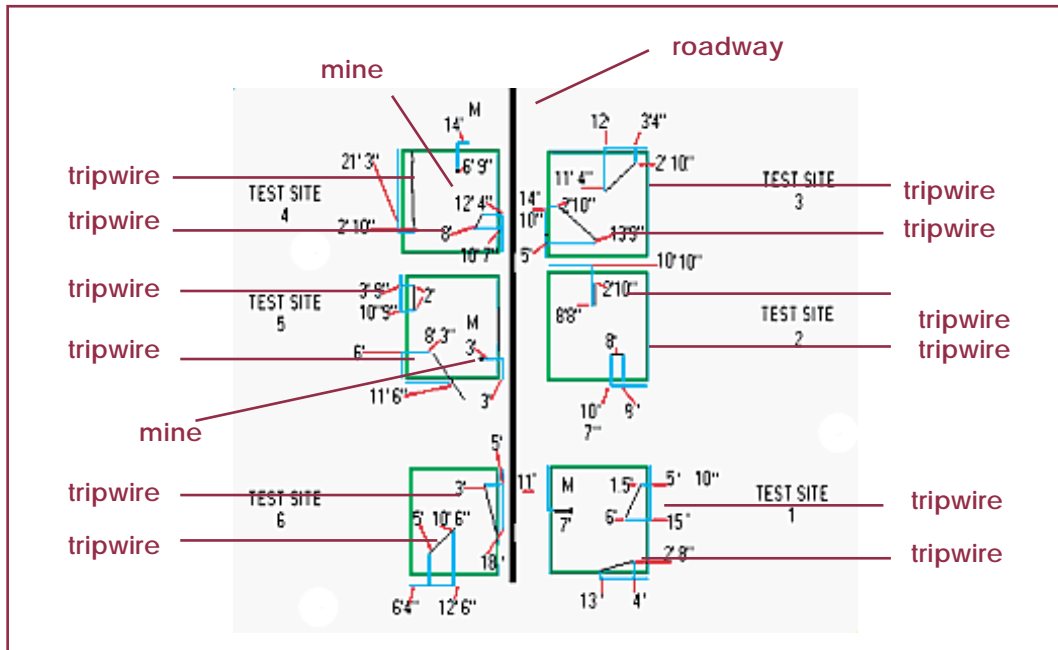

4. There were three groups (two dogs per group) used in testing for this project.
  - a. Group #1 dogs ran the Test Field on 11-16 April 2001. Don (German shepherd, male) was trained on mines and tripwire. The second dog, Kasey (Belgian Malinois, male), trained only on mines.



*Don G1784.*



*Kasey G1866.*

- b. Group #2 dogs ran the Test Field on 22-25 May 2001. These two dogs were retired mine detection dogs Rosa (Belgian Malinois, female) and Blanca (Belgian Malinois, female). Each dog was trained on mines and tripwire. Both of these dogs saw service in the Balkans, Africa and GITMO (Cuba).



Rosa G1114.



Blanca G1571.

c. Group #3 ran the Test Field 22 June to 9 July 2001. TJ (German shepherd, male) and Shatan (German shepherd, male) were both trained in the laboratory to detect the chemical compound for tripwire. Then each dog was trained to search straight lines similar to that of a regular mine detection dog. At no time in the project did these dogs come in contact with actual tripwire until they were placed in the project test field.



Shatan G1885.



Tjebbs (TJ) G1887.

5. The following data is extracted from the test evaluation data for comparison. This data along with the trainer/handler comments determine the test results.

a. Don searched all six test sites with the following results trained on mines and tripwires):

| Site | Tripwire | Mine | Temp/<br>humidity | Soil moisture | Wind (mph) | Barometric |
|------|----------|------|-------------------|---------------|------------|------------|
| # 1  | 1/2      | 1/1  | 69 F 83%          | 15%           | 3-5        | 29.13      |
| # 2  | 1/2      |      | 77 F 80%          | 10%           | 1-3        | 29.21      |
| # 3  | 2/2      |      | 70 F 92%          | 10%           | 2-4        | 29.32      |
| # 4  | 1/2      | 0/1  | 77 F 88%          | 10%           | 1-3        | 29.21      |
| # 5  | 2/2      | 0/1  | 74 F 68%          | 0             | 3-5        | 29.32      |
| # 6  | 2/2      |      | 72 F 50%          | 0             | 4-6        | 29.68      |

b. Kasey (trained on mines only) searched all six test sites with the following results:

| Site | Tripwire | Mine | Temp/<br>humidity | Soil moisture | Wind (mph) | Barometric |
|------|----------|------|-------------------|---------------|------------|------------|
| # 1  | 0/2      | 0/1  | 77F 76%           | 10%           | 2-3        | 29.31      |
| # 2  |          | 0/2  | 70F 92%           | 10%           | 2-4        | 29.32      |
| # 3  |          | 0/2  | 74F 77%           | 10%           | 1-3        | 29.21      |
| # 4  | 0/2      | 0/1  | 83F 73%           | 15%           | 2          | 29.15      |
| # 5  | 1/2      | 1/1  | 75F 49%           | 0             | 3-5        | 29.71      |
| # 6  |          | 0/2  | 74F 72%           | 0             | 3-6        | 29.32      |

c. Rosa searched all six test sites with the following results (trained on mines and tripwires):

| Site | Tripwire | Mine | Temp/<br>humidity | Soil moisture | Wind (mph) | Barometric |
|------|----------|------|-------------------|---------------|------------|------------|
| # 1  | 2/2      | 1/1  | 70F 50%           | 5%            | 0-1        | 29.46      |
| # 2  | 2/2      |      | 73F 65%           | 0             | 1-4        | 29.32      |
| # 3  |          | 2/2  | 70F 89%           | 0             | 4-5        | 29.18      |
| # 4  | 2/2      | 1/1  | 67F 59%           | 0             | 0-1        | 29.33      |
| # 5  | 2/2      | 1/1  | 67F 80%           | 5%            | 3-4        | 29.29      |
| # 6  |          | 2/2  | 70F 89%           | 0             | 4-5        | 29.18      |

Note: Rosa walked parallel to tripwire sniffing and returned to handler. Next time while searching lanes the dog responded on the tripwire.

d. Blanca searched all six test sites with the following results (trained on mines and tripwires):

| Site | Tripwire | Mine | Temp/<br>humidity | Soil moisture | Wind (mph) | Barometric |
|------|----------|------|-------------------|---------------|------------|------------|
| # 1  | 1/2      | 0/1  | 70F 69%           | 0             | 0-1        | 29.32      |
| # 2  |          | 2/2  | 75F 53%           | 5%            | 1-4        | 29.45      |
| # 3  |          | 2/2  | 68F 66%           | 5%            | 0-1        | 29.33      |
| # 4  | 2/2      | 1/1  | 72F 90%           | 0             | 4-5        | 29.16      |
| # 5  | 2/2      | 1/1  | 68F 73%           | 0             | 3-6        | 29.16      |
| # 6  |          | 2/2  | 68F 77%           |               | 5%         | 3-4        |

Note: Slow to detect is counted as a miss.

e. TJ (trained on synthetic tripwire only) searched all test sites with the following results:

| Site | Tripwire | Mine | Temp/<br>humidity | Soil moisture | Wind (mph) | Barometric |
|------|----------|------|-------------------|---------------|------------|------------|
| # 1  | 0/2      | 0/1  | 98F 57%           | 0             | 2-4        | 29.35      |
| # 2  | 0/2      |      | 104F 50%          | 0             | 4-6        | 29.30      |
| # 3  | 0/2      |      | 83F 81%           | 5%            | 3-5        | 29.38      |
| # 4  | 0/2      | 0/1  | 87F 81%           | 5%            | 2-4        | 29.38      |
| # 5  | 0/2      | 0/1  | 75F 73%           | 5%            | 0-1        | 29.35      |
| # 6  | 0/2      |      | 104F 47%          | 0             | 4-6        | 29.30      |

f. Shatan (trained on synthetic tripwire only) ran all test sites with the following results:

| Site | Tripwire | Mine | Temp/<br>humidity | Soil moisture | Wind (mph) | Barometric |
|------|----------|------|-------------------|---------------|------------|------------|
| # 1  | 0/2      | 0/1  | 80F 86%           | 5%            | 3-6        | 29.37      |
| # 2  | 0/2      |      | 81F 86%           | 5%            | 2-6        | 29.36      |
| # 3  | 0/2      |      | 93F 59%           | 0             | 2-4        | 29.35      |
| # 4  | 0/2      | 0/1  | 85F 79%           | 0             | 4-6        | 29.30      |
| # 5  | 0/2      | 0/1  | 104F 50%          | 0             | 4-6        | 29.30      |
| # 6  | 0/2      |      | 76F 76%           | 5%            | 0-1        | 29.35      |

6. The following statistical data is a total for each dog involved in this project. It is interesting that the two retired dogs (Rosa, Blanca) did the best despite some adverse factors, especially soil moisture.

| Name   | T/W   | Mines | Temp/humidity | Soil moisture |
|--------|-------|-------|---------------|---------------|
| Don    | 9/12  | 1/3   | 73.6F 64.8%   | 7.5%          |
| Kasey  | 1/12  | 1/3   | 75.5F 73.2%   | 7.5%          |
| Rosa   | 12/12 | 3/3   | 69.9F 72%     | 1.6%          |
| Blanca | 11/12 | 2/3   | 70.1F 64.8%   | 2.5%          |
| T.J.   | 0/0   | N/A   | 91.8F 72.6%   | 2.5%          |
| Shatan | 0/0   | N/A   | 86.5F 72.6%   | 2.5%          |

7. The last requirement of this project is to write a final report and recommendation. These recommendations will be in the form of a Tripwire Training Protocol (see Annex 1).



## Annex 3

## Interim study report and summary of results, 27 February 2001

1. On 23 January the test chemicals which simulated the detected odours found on tripwire were received from TRI. The vapour from the simulated tripwire is extracted from a sealed container by syringe. The vapour is then captured on gauze pads. These gauze pads are used as training aids. The gauze pads are placed in large-mouth half-pint (300 cc) jars and used in training the dog to detect the simulated tripwire. See photos of vapour transfer procedure in preparation of training aids.



*Preparing gauze pads for vapour collection.*



*Vapour extraction syringe.*





*Extracting tripwire vapour.*



*Injecting vapour into training aid jar.*

2. The Tripwire Test Site was prepared on 24 and 25 January. The Test Site should be set up six weeks prior to testing dogs. A total of six 10m<sup>2</sup> plots were made containing tripwires and mines.
3. The dogs Shatan G1885 and Tjebbs G1887 were placed into training using the protocol outlined in our letter dated 20 January 2001. Training commenced on 26 January 2001. This portion of the training is being video taped daily for approximately three minutes per dog. All training is being documented in a ledger. At present both dogs are on their 15<sup>th</sup> day of training. A total of 822 trials on simulated tripwire have been conducted.
4. Don G1748 received proficiency training for detection of mines and tripwires. This dog is being maintained for the test portion of the tripwire study.
5. Kasey G1866 received proficiency training in mine detection. This dog is being maintained for the test portion of the tripwire study.
6. Bingo G1821 is being maintained as a back-up dog for Kasey and Don. Some proficiency training in search pattern and detection of mines only is being conducted.
7. We expect the actual testing of all four dogs to be accomplished around 20 March 2001.

## Annex 4

## Interim study report, 20 January 2001

1. On 27 October 2000, a meeting was held at Global Training Academy (Global) with Walter Zoch from TRI/Austin, Dan Hayter, Clarke Young and Jim Parks. We discussed the IMAS Contract # S-LMAQM-99-0144, *Task Order # 00-44, Mine Detection Dog Tripwire Study*. Portions of tripwire for various locations were provided to TRI for analysis:
  - Plastic covered tripwire from a Bosnia minefield from Sarajevo area.
  - Plastic covered tripwire from a minefield in Bosnia from Mostar area.
  - Painted metal tripwire from Croatia.
2. The following Global personnel, Dan Hayter, Paul Brown and Clarke Young are assigned to the project to assist with training, testing and developing a Testing Protocol. All the above listed personnel have over 10 years experience in the Mine Detection Dog Program.
3. The preliminary analysis data from TRI (Annex 5) was received on 21 November . This information indicated that all the tripwire samples were showing low levels of TNT and DNT. It was also noted that some of the wire contained plasticizers, which have a distinct chemical vapour of their own. The painted wires also contain a recognisable chemical vapour.
4. Global decided to extend TRI involvement in the study by obtaining additional tripwire, which hadn't been exposed knowingly to explosives. Global, with the assistance from the GICHD and from Hobby Hobson (RONCO's EOD expert), obtained additional tripwire which hadn't been used in or around explosives or mines.
5. On 6 December 2000, this tripwire was transported to TRI in Austin, by Clarke Young and given to Walter Zoch.
6. On 28 December 2000, Global obtained additional tripwire from Mozambique. This wire was apparently unused and had been lying along a railroad line in Mozambique where RONCO was demining. This information will be included in the study.
7. The following dogs are being trained and used in support of this project:
  - Don G1748 is being trained on mines and tripwire using Global Training Academy's Mine Dog Training Protocol. The objective is to test our present method training and compare the results with the protocol tripwire dog.
  - Kasey G1866 is being trained on mines only and is to be used in the test to see how well a dog not trained on tripwire will perform as against dogs trained on wire and mines together.
  - Bingo G1821 has received some training on mines and is a back-up dog for Kasey and Don.

- Shatan G1885 is currently being trained in obedience and ball retrieve. This dog will be trained using the Protocol developed from the information from TRI.
- Tjebbs G1887 is currently being trained in obedience and ball retrieve. This dog will be trained using the Protocol developed from the information from TRI.

## Annex 5

# Chemical analysis of tripwires

The following is a summary of the laboratory analysis report on samples of tripwire prepared by TRI/Austin, Inc.<sup>1</sup> in 2001.

## Analytical approach

Multiple samples identified as tripwires were received at TRI/Austin. Table 1 summarises the samples received and analysed. The tripwires were analysed for residual explosive components and other organic constituents that may be characteristic of the wires. Analysis of wire samples was conducted by heated headspace SPME-GCMS (Gas Chromatography/Mass Spectrometry). Each wire was sampled by placing the entire length of wire material inside a pre-cleaned Teflon-liner glass vial and gently heating to 50°C. The glass vial was then allowed to temperature equilibrate for 30 minutes. A pre-conditioned Supelco Solid Phase Micro Extraction (SPME) fiber was next inserting through the Teflon septum allowing analytes to diffuse and collect on the SPME fibre adsorbent for 60 minutes. The SPME fibre consisted of a pre-conditioned fibre coated with 75µm of Carboxen/PDMS (Poly DiMethyl Siloxane) sorbents. These sorbents have a high affinity for volatile hydrocarbons. Fig. 1 presents SPME sampling device and Fig. A illustrates the extraction and desorption procedure used for these samples.

| Sample description        | Project no, | Date analysed |
|---------------------------|-------------|---------------|
| Tripwire #1 (Cr.)         | Project 1   | 11/16/00      |
| Tripwire # 4 (B.)         | Project 1   | 11/16/00      |
| Tripwire #5 (B/D)         | Project 1   | 11/16/00      |
| Virgin non-coated wire    | Project 2   | 12/15/00      |
| Virgin coated wire        | Project 2   | 12/15/00      |
| Mozambique unpainted wire | Project 3   | 1/17/01       |
| Mozambique painted wire   | Project 3   | 1/17/01       |

After SPME sample collection, the SPME fibre is placed directly inside an OPTIC 2 Inlet, pre-cooled to 35°C, operating in the thermal desorption mode. The SPME fibre is rapidly thermally desorbed at 250°C and the analytes cryogenically focused at 60°C onto a high resolution capillary column. The column was interfaced to a mass selective detector operating in the full scan acquisition mode. Identification of detected analytes was based on comparison of unknown spectra to search results of 129,000 NBS/NIST compound mass spectral library.

1. TRI/Austin, 9063 Bee Caves Rd. Austin, TX 78733, U.S., Tel: 01- 512/263-2101, Fax: 01- 512/263-2558.



Figure 1  
SPME sampling apparatus

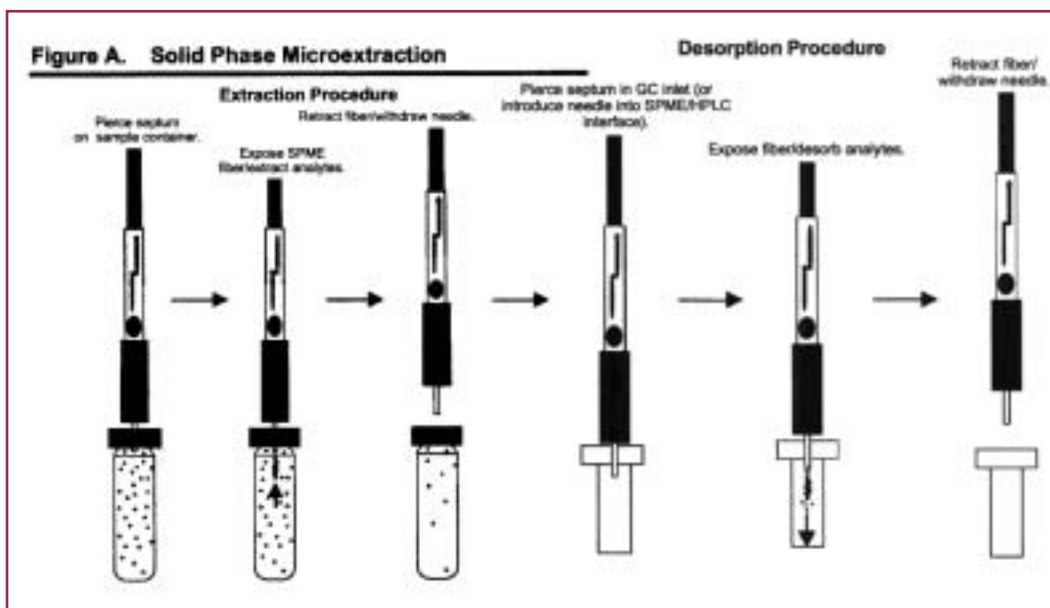

### Discussion of results

Each wire sample was evaluated for the presence of residual explosive components and other characteristic hydrocarbons. Fig. 2 shows the chemical structure of the explosive compounds that were detected in some of the wire samples.

Figure 2  
DNT Degradation & TNT

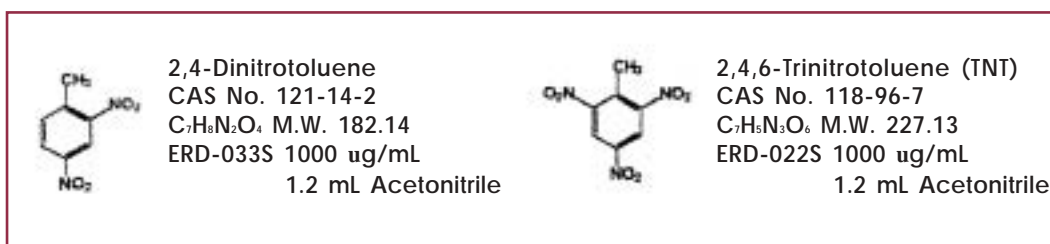

Highest amounts of residual explosive materials (DNT and TNT) were detected in Project 1 sample numbers 1,4, and 5 (Cr., B. and B/D).

An extremely trace amount of DNT was detected in Project 2 Virgin Non-coated wire. In all remaining wires no explosive constituents were detected. Significant amounts of hydrocarbons were measured in several of the coated wire samples. These hydrocarbons are typical of compounds found in painted and polymer coated materials. The two wire samples identified as Mozambique painted and unpainted contained small amounts of measurable hydrocarbon material. Based on inspection of these two wires and the low levels of hydrocarbon, are both indicative that these samples are well weathered. Tables 2-7 provide a summary of the hydrocarbons identified in each sample. SPME-GCMS Chromatograms have been included to provide a visual reference of the amount of material measured in each analysis.

**Table 2**  
Hydrocarbons identified for tripwire # 1

| Tentative identification    | Ret. time | Molecular weight | Cr. tripwire GCMS-SPME |
|-----------------------------|-----------|------------------|------------------------|
| 2,4,6-Trinitrotoluene (TNT) | 21.29     | 210              | detected               |
| 2,4-Dinitrotoluene (DNT)    | 20.48     | 182              | detected               |
| Hexanal                     | 11.96     | 98               | detected               |
| Furfural                    | 12.65     | 96               | detected               |
| Ethylbenzene                | 13.38     | 106              | detected               |
| Xylene                      | 13.87     | 106              | detected               |
| Decane                      | 15.68     | 142              | detected               |
| Hexachloroethane            | 17.02     | 236              | detected               |
| Undecane                    | 17.14     | 156              | detected               |
| Nonanal                     | 17.22     | 124              | detected               |
| Naphthalene                 | 18.21     | 128              | detected               |

**Figure 3**  
GCMS-SPME chromatogram of tripwire #1 (C)

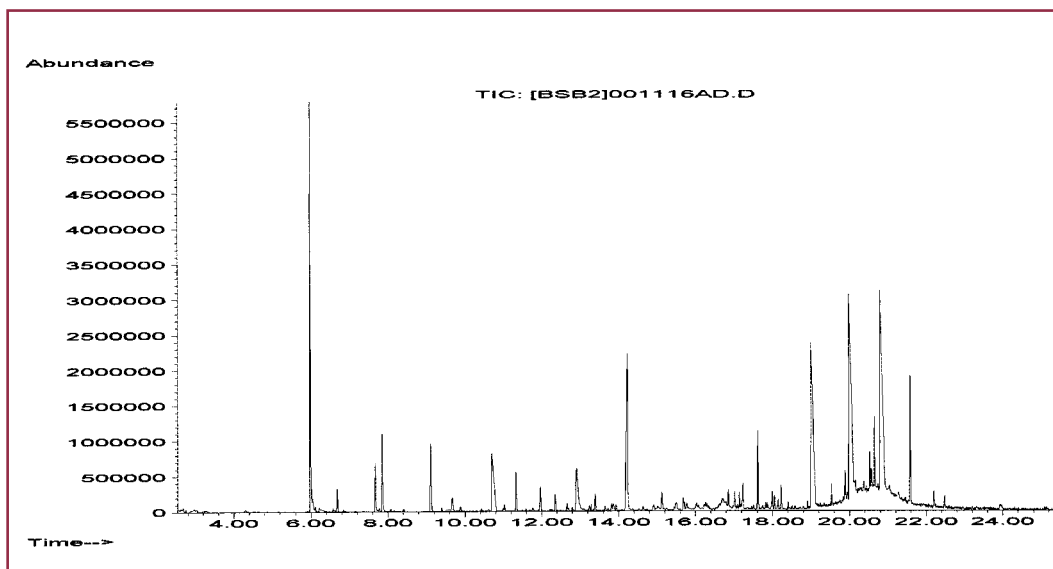
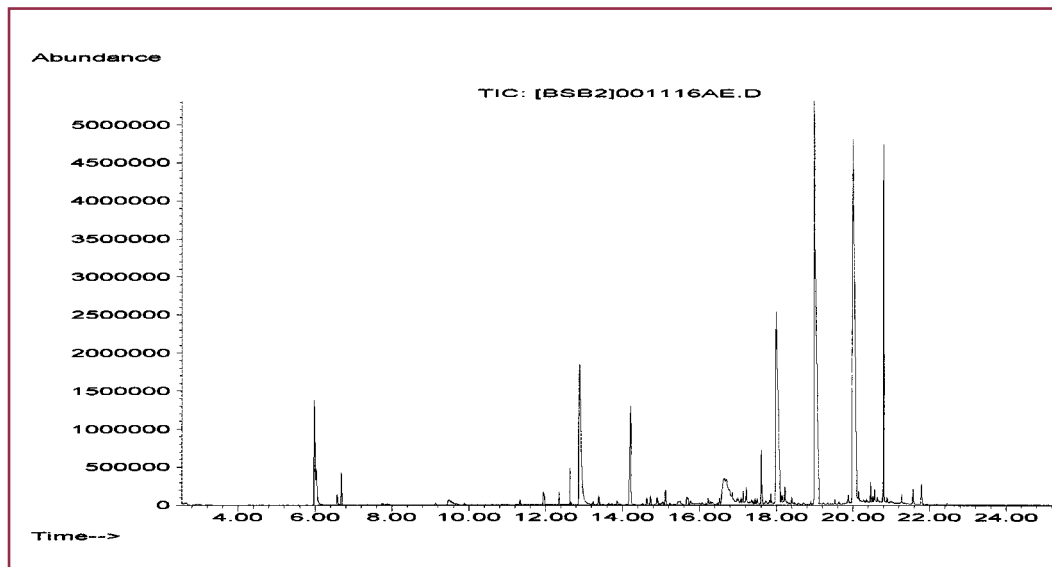

Table 3  
Hydrocarbons identified for tripwire # 4

| Tentative identification    | Ret. time | Molecular weight | Cr. tripwire GCMS-SPME |
|-----------------------------|-----------|------------------|------------------------|
| 2,4,6-Trinitrotoluene (TNT) | 21.27     | 210              | detected               |
| 1,2-Dinitrobenzene (DNB)    | 20.14     | 168              | detected               |
| 2,4-Dinitrotoluene (DNT)    | 20.27     | 182              | detected               |
| 2,5-Dinitrotoluene (DNT)    | 20.46     | 182              | detected               |
| 2,6-Dinitrotoluene (DNT)    | 20.55     | 182              | detected               |
| Ethylbenzene                | 13.39     | 106              | detected               |
| Xylene                      | 13.86     | 106              | detected               |
| Alpha-Pinene                | 14.63     | 136              | detected               |
| Methyl pentanone            | 14.73     | 98               | detected               |
| Benzaldehyde                | 15.12     | 106              | detected               |
| Butylbenzene                | 17.08     | 134              | detected               |
| Undecane                    | 17.13     | 156              | detected               |
| Nonanal                     | 17.22     | 124              | detected               |
| Dimethyl styrene            | 17.86     | 132              | detected               |
| Tetrahydronaphthalene       | 17.98     | 132              | detected               |
| Naphthalene                 | 18.22     | 128              | detected               |
| Tridecane                   | 18.90     | 184              | detected               |
| Tetradecane                 | 19.53     | 198              | detected               |

Figure 4  
GCMS-SPME chromatogram of tripwire # 4 (B)



**Table 4**  
Hydrocarbons identified for tripwire # 5

| Tentative identification     | Ret. time | Molecular weight | Cr. tripwire GCMS-SPME |
|------------------------------|-----------|------------------|------------------------|
| 2,4,6-Trinitrotoluene (TNT)  | 21.27     | 210              | detected               |
| 1,2-Dinitrobenzene (DNB)     | 20.14     | 168              | detected               |
| 2,4-Dinitrotoluene (DNT)     | 20.27     | 182              | detected               |
| 2,5-Dinitrotoluene (DNT)     | 20.46     | 182              | detected               |
| 2,6-Dinitrotoluene (DNT)     | 20.56     | 182              | detected               |
| Furfural                     | 12.65     | 96               | detected               |
| Hydroxymethyl pentanone      | 12.86     | 116              | detected               |
| Ethylbenzene                 | 13.38     | 106              | detected               |
| Xylene                       | 13.86     | 106              | detected               |
| Decane                       | 15.66     | 142              | detected               |
| Acetophenone                 | 16.84     | 120              | detected               |
| Butylbenzene                 | 17.08     | 134              | detected               |
| Undecane                     | 17.13     | 156              | detected               |
| Nonanal                      | 17.21     | 124              | detected               |
| Tetramethyl benzene          | 17.49     | 134              | detected               |
| Tetrahydronaphthalene        | 17.98     | 132              | detected               |
| Dodecane                     | 18.12     | 170              | detected               |
| Naphthalene                  | 18.21     | 128              | detected               |
| Tetramethylbicyclo heptanone | 18.40     | 166              | detected               |
| Tetradecane                  | 19.53     | 198              | detected               |
| Lindane                      | 21.79     | 290              | detected               |

**Figure 5**  
GCMS-SPME chromatogram of tripwire #5 B/D

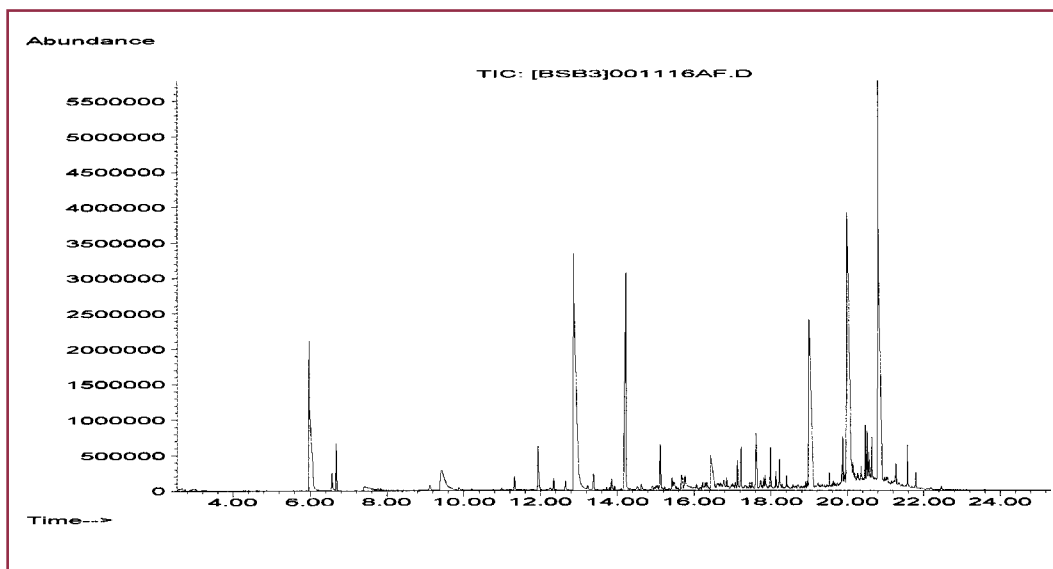

**Table 5**  
Hydrocarbons identified for virgin non-coated wire

| Tentative identification    | Ret. time | Molecular weight | Cr. tripwire GCMS-SPME |
|-----------------------------|-----------|------------------|------------------------|
| 2,4,6-Trinitrotoluene (TNT) | 21.27     | 210              | not detected           |
| 1,2-Dinitrobenzene (DNB)    | 20.14     | 168              | not detected           |
| 2,4-Dinitrotoluene (DNT)    | 20.02     | 182              | trace                  |
| 2,5-Dinitrotoluene (DNT)    | 20.46     | 182              | not detected           |
| 2,6-Dinitrotoluene (DNT)    | 20.55     | 182              | not detected           |
| Propylbenzene               | 14.65     | 120              | detected               |
| Trimethylbenzene            | 14.77     | 120              | detected               |
| Ethy;methy;benzene          | 14.99     | 120              | detected               |
| Trimethylbenzene            | 15.23     | 120              | detected               |
| Octanal                     | 15.30     | 110              | detected               |
| Trimethylbenzene            | 15.76     | 120              | detected               |
| Butylbenzene                | 16.63     | 134              | detected               |
| Nonanal                     | 16.78     | 124              | detected               |
| Naphthalene                 | 17.78     | 128              | detected               |
| Benzothiazole               | 18.14     | 135              | detected               |
| Pentadecane                 | 19.64     | 212              | detected               |

**Figure 6**  
GCMS-SPME chromatogram of virgin non-coated wire

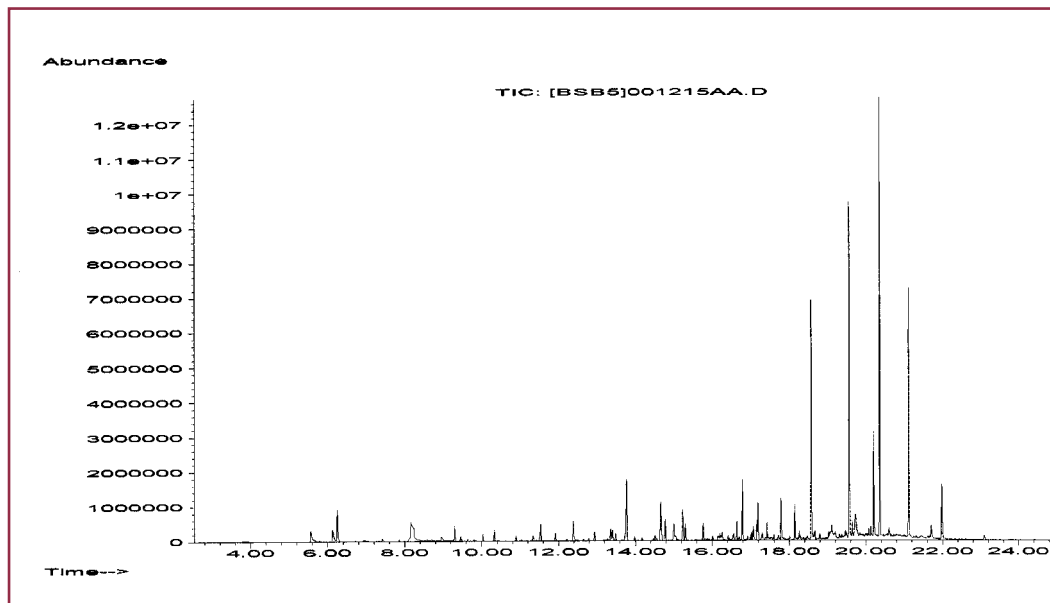



**Table 6**  
Hydrocarbons identified for virgin coated wire

| Tentative identification    | Ret. time | Molecular weight | Cr. tripwire GCMS-SPME |
|-----------------------------|-----------|------------------|------------------------|
| 2,4,6-Trinitrotoluene (TNT) | 21.27     | 210              | not detected           |
| 1,2-Dinitrobenzene (DNB)    | 20.14     | 168              | not detected           |
| 2,4-Dinitrotoluene (DNT)    | 20.02     | 182              | not detected           |
| 2,5-Dinitrotoluene (DNT)    | 20.46     | 182              | not detected           |
| 2,6-Dinitrotoluene (DNT)    | 20.55     | 182              | not detected           |
| Hexanal                     | 11.78     | 98               | detected               |
| Ethylbenzene                | 13.07     | 106              | detected               |
| Xylene                      | 13.22     | 106              | detected               |
| Styrene                     | 13.64     | 104              | detected               |
| Heptanal                    | 13.78     | 114              | detected               |
| Benzaldehyde                | 14.95     | 106              | detected               |
| Octanal                     | 15.59     | 110              | detected               |
| Dichlorobenzene             | 15.88     | 146              | detected               |
| Nonanal                     | 17.09     | 124              | detected               |
| Dimethylbicyclo heptanone   | 17.61     | 138              | detected               |
| Camphor                     | 17.69     | 152              | detected               |
| Tetrahydronaphthalene       | 17.86     | 132              | detected               |
| Trimethylbicyclo heptanone  | 17.98     | 152              | detected               |
| Dodecane                    | 18.02     | 170              | detected               |
| Naphthalene                 | 18.10     | 128              | detected               |

**Figure 7**  
GCMS-SPME chromatogram of virgin coated wire

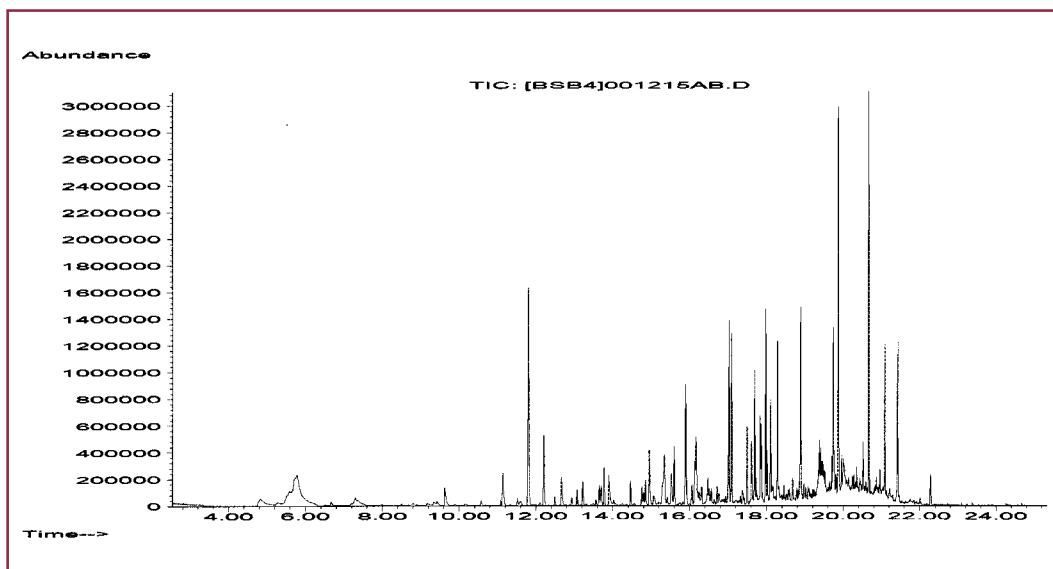
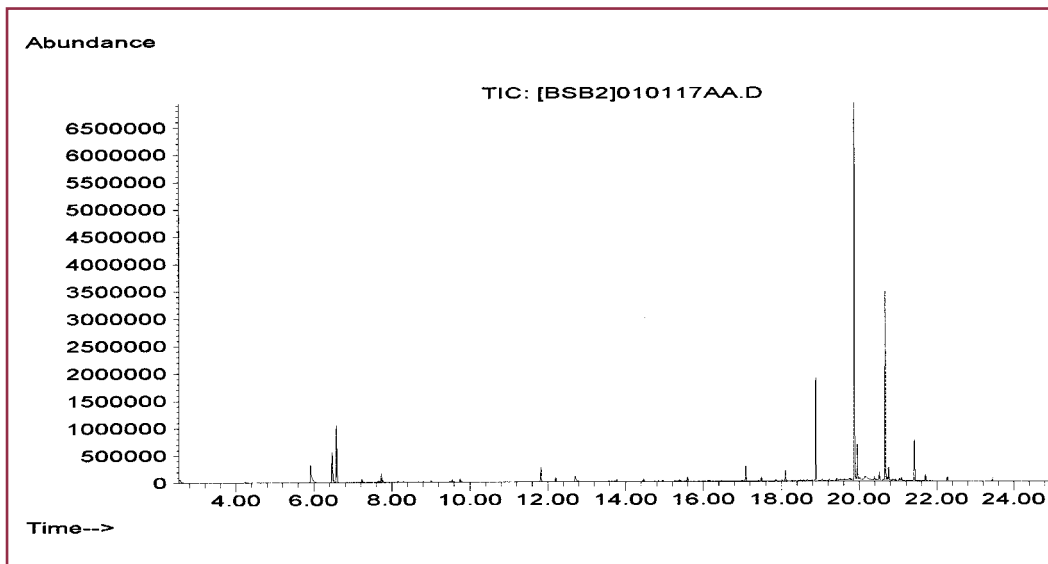

Table 7  
Hydrocarbons identified for Mozambique unpainted wire

| Tentative identification    | Ret. time | Molecular weight | Cr. tripwire GCMS-SPME |
|-----------------------------|-----------|------------------|------------------------|
| 2,4,6-Trinitrotoluene (TNT) | 21.27     | 210              | not detected           |
| 1,2-Dinitrobenzene (DNB)    | 20.14     | 168              | not detected           |
| 2,4-Dinitrotoluene (DNT)    | 20.02     | 182              | not detected           |
| 2,5-Dinitrotoluene (DNT)    | 20.46     | 182              | not detected           |
| 2,6-Dinitrotoluene (DNT)    | 20.55     | 182              | not detected           |
| Hexanal                     | 11.81     | 98               | detected               |
| Alpha-Pinene                | 14.46     | 136              | detected               |
| Nonanal                     | 17.09     | 124              | detected               |
| Naphthalene                 | 18.10     | 128              | detected               |

Figure 8  
GCMS-SPME chromatogram of Mozambique unpainted wire



**Table 8**  
Hydrocarbons identified for Tripwire # 1

| Tentative identification    | Ret. time | Molecular weight | Cr. tripwire GCMS-SPME |
|-----------------------------|-----------|------------------|------------------------|
| 2,4,6-Trinitrotoluene (TNT) | 21.27     | 210              | not detected           |
| 1,2-Dinitrobenzene (DNB)    | 20.14     | 168              | not detected           |
| 2,4-Dinitrotoluene (DNT)    | 20.02     | 182              | not detected           |
| 2,5-Dinitrotoluene (DNT)    | 20.46     | 182              | not detected           |
| 2,6-Dinitrotoluene (DNT)    | 20.55     | 182              | not detected           |
| Pentanal                    | 9.73      | 86               | not detected           |
| Octene                      | 11.62     | 112              | not detected           |
| Hexanal                     | 11.81     | 100              | detected               |
| Heptanal                    | 13.77     | 114              | detected               |
| Octanal                     | 15.59     | 128              | detected               |
| Nonanal                     | 17.08     | 142              | detected               |

**Figure 9**  
GCMS-SPME chromatogram of Mozambique painted wire

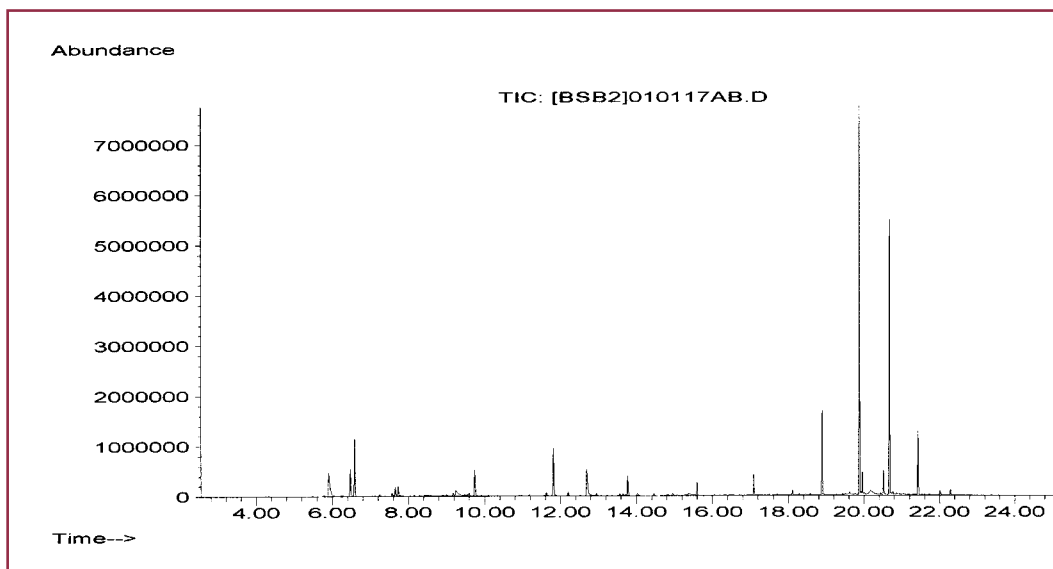
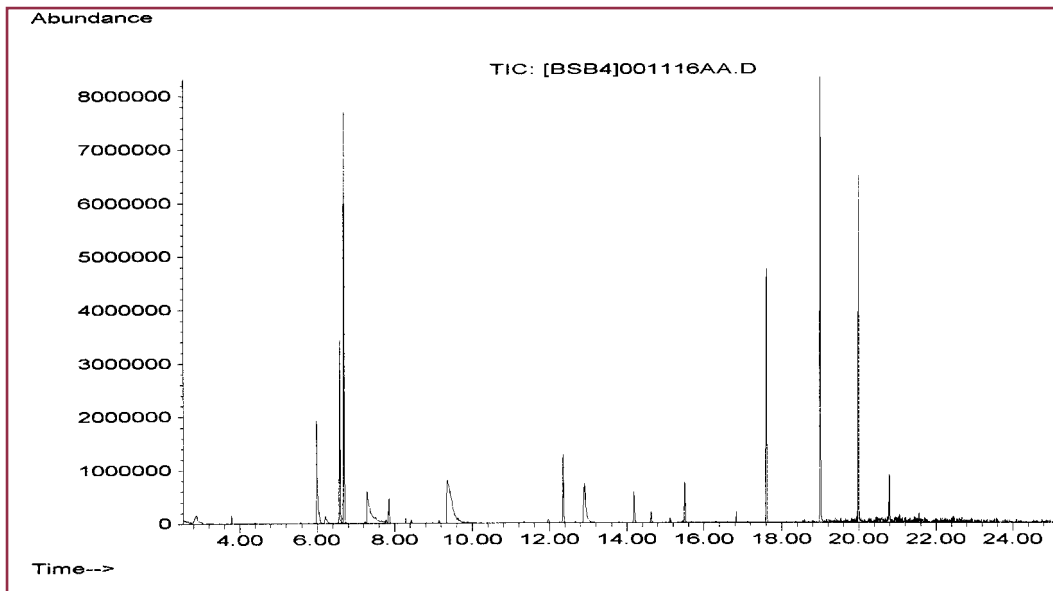

Figure 10  
GCMS-SPME chromatogram of SPME fibre blank



## Chapter 3

### Training, organisation and skills: case studies of practice using mine detection dogs

# Training, organisation and skills: case studies of practice using mine detection dogs

*Per Jostein Matre*

## Introduction

Mine-seeking dogs are one of several tools available to those engaged in mine-clearance. Dogs have shown themselves to be effective mine detection tools, and the potential and advisability of using dogs for this purpose are now widely acknowledged.

This chapter presents an overview of issues identified in sub-study III of the programme of research on the use of mine detection dogs initiated by the GICHD in 2000. The study was originally conceived as a series of eight modules. However, the objectives were considerably adjusted as a result of comments made by the GICHD MDD Advisory Group, and became much more focused on a smaller set of issues. This report centres on case studies of four organisations that either train or use mine detection dogs. The study should be read alongside a separate report prepared by NOKSH on the general learning principles for training REST dogs (Chapter 1, Part 2).

## Objectives

The modified objectives of the study were to describe:

- The administrative structures within which mine detection dogs are produced;
- The methods used for selecting and training dogs; and
- The training of instructors and handlers.

## Methods

An operational requirement for implementation of the study was to develop a dialogue with central participants in the field. The methodological approach was to make a qualitative evaluation of existing practice within the target organisations.



During the year covered by the programme most of the work was carried out in cooperation with four organisations. Two of these are producers of MDDs: Global Training Academy (GTA, based in Texas) and Humanity Dog (HD in Sweden). The third is a dog training organisation and also part of the GICHD study on training methods, Fjellanger Dog Training Academy (FDTA, in Norway). The fourth is a broadly-based humanitarian agency that uses mine detection dogs as part of its programme, Norwegian People's Aid (NPA). Details of visits to these agencies are listed in Annexes 1-4.

The visits to these organisations are presented as case analyses. The overlap of practice between the organisations is explored in order to better understand operational similarities and differences among them.

Information was collected through open and semi-structured interviews and from direct observation. Written records or videos were made and used to produce summary reports about each organisation. Each report was then sent to the organisation for comment and approval before being included in this final report. The method used by the researcher in each case was the same, with some minor adjustments to cater for commercial confidentiality.

Both in advance and during the interviews, the interview content was presented to an independent party for comment. This process resulted in suggestions as to how the information obtained could be analysed. As a result, the information was evaluated as a traditional qualitative study.

This approach produced perspectives on four focal areas:

- The organisation as a support factor for the trainers;
- The policy and practice for hand-over of dogs from organisation to users;
- The knowledge accumulation process used by the organisation; and
- Staff training procedures.

Information about training of dogs was analysed using keynote terms derived from learning theory (Catania, 1992; Kazdin, 1994). Central concepts were:

- **Establishment** of response (e.g. how is a behavioural pattern established?);
- **Maintenance** of response (e.g. how is a behavioural pattern maintained?); and
- **Generalisation** (e.g. what is the process used to allow transfer of an established behavioural pattern to a new practical context?).

Information about the behaviour of trainers and dog handlers was analysed using keynote principles derived from problem solving practice in adult therapy (Schon, 1987). Central concepts were:

- Analysis of the training process;
- Procedures for dealing with training problems;
- Procedures for personal evaluation; and
- Observation skills.

Each focal area of study was related to current practice. At all times efforts were made to ensure the use of a common terminology for the study analysis and the everyday situation of the trainers and the dog handlers.

## Results

The following overviews summarise general patterns that emerged from the case studies. The individual case studies are presented as annexes.

### *Identification of test criteria for the selection of mine detection dogs*

The objective of describing a method for identifying test criteria for the selection of dogs for training as MDDs was not achieved, due to resistance within the industry to attempts to document the process. However, it is both possible and desirable to continue to address this objective, despite indications in the literature that the process has low reliability (review in GICHD, 2001). Trainers of MDDs certainly use selection procedures to identify suitable dogs, and they place considerable reliance on those procedures (e.g. K. Schultz, pers. comm.; Humanity Dog, pers. comm.). In general terms, those procedures have not been well documented and exist almost entirely as “private” (undocumented) knowledge of the individuals conducting the tests.

Test situations were observed at Humanity Dog in Sollefteå, Sweden. The test course was built on traditional principles and challenged the reactions and responses of the dog under specific circumstances, such as response to a loud noise or a person appearing suddenly. The person administering the tests awarded scores in the various test categories, but the scores were neither absolute nor operationalised.

The selection process differs between organisations and no standard testing procedure exists. However, the following common elements can be identified:

- The dog must be relatively healthy;
- The dog must be highly motivated for the job;
- The dog must exhibit a high degree of social behaviour;
- The dog must exhibit the traits characteristic for the breed;
- The dog must be inquisitive;
- The dog must exhibit a high behavioural stability under sudden and unexpected circumstances;
- The dog must not be aggressive;
- The dog must show an ability to bond with humans;
- The dog must be active;
- The dog must be able to be controlled;
- The dog must react to stimuli;
- The dog must not become stressed during normal daily experiences;
- The dog must not exhibit negative traits (e.g aggression, low confidence, excitability).

Two issues arise. First, is it possible to identify and document the skills and criteria being used to make selections? Second, does the process of selection actually result in improved reliability among the dogs chosen? There clearly is a belief existing in the relevant agencies that the selection process improves the quality of operational dogs. The people who make selections and their undocumented skills represent an important and currently unexplored opportunity to further advance this objective.

### *Guidelines for the training and handling of mine detection dogs*

Major participants in the industry generally operate in a similar fashion when training dogs. The following stages can be identified. However, there was considerable variation in the time frame and little consensus on a definition of each stage, so neither is provided here. In general, training is initiated at a dog age of 14-18 months, and the overall training process takes 6-9 months.

Training is divided roughly as follows:

- Pre-training — including socialising;
- Establishment of basic responses;
- Establishment of complex responses — behaviour-linking;
- Response-maintenance using repetition, including necessary amendment to reinforcement schedules (see Chapter 1, Part 2);
- Transfer and generalisation; and
- Training of dog-handler, and hand-over.

### *General guidelines for educational programmes for trainers and handlers*

The procedures for training the trainers and dog handlers varied considerably among the three organisations that undertook this task. Although the training course itself was sometimes well documented, few practical procedures existed for documenting and monitoring the effectiveness of training on the skills of trainers and handlers. Informal oral procedures clearly existed and were the main procedure used for transferring information, but the consistency and quality of their use is unknown.

With the absence of formal recording procedures in mind, a proposed checklist for rating skill-levels of both trainers and handlers was drawn up (see Annex 5) with the objective of allowing for both: (1) monitoring the development of trainer and handler skills, including allowing feedback during the training process; and (2) providing an objective record of the effects of the programme. The components of the checklist were extracted from information gathered during the case studies, so reflect the views of major organisations in the field.

## **Discussion**

The training of dogs incorporates elements of both systematic approaches and some mythology, and tends to rely heavily on the skills of key individuals. Documentation of training procedures is rarely attempted, apparently because individual training styles are regarded as idiosyncratic and therefore difficult to transfer between trainers. In reality, some common themes can be identified which go beyond fundamental principles obtainable in any basic psychology text. A first attempt to identify such principles is made here.

### *Training methods*

All training and adjustment, whatever the race or type of dog, exhibits the following common characteristics:

- Identification of possibilities, problem areas, strengths and weaknesses;
- Prioritising of the findings (what do we start with and what do we get?);
- Problem formulation;
- Objective (aim) formulation;
- Planning and carrying out actions;
- Evaluation of training/adjustment processes and the results obtained; and
- Repetition of the above evaluation loop (repetition is the mother of retention).

When the NOKSH observations were placed in this framework it became apparent that the methods did not vary as much as had been expected or was portrayed by the interviewees. In reality, training methods at the different organisations could be divided into just two or three categories, all of which are well known. These methods and procedures are outlined in Table 1, together with strengths and weaknesses.

In three of the four cases, forward chaining was the preferred training method. Backward chaining and shaping were rarely used in those organisations, despite the known effectiveness of shaping as a training tool (e.g. Chapter 1, Part 2). The reasons for not using shaping are not known but it could be that trainers have no confidence in this “modern” training method. A comment made at one MDD Advisory Group meeting by a senior member of one of the case study organisations supports this view: “We tried shaping, but it didn’t work”. A central feature of shaping is that it maintains the independence of the dog from the trainer/handler. Most trainers comment that the relationship between the handler and dog is central to successful mine detection. They are therefore unlikely to trust training procedures that maintain independence in a mine detection dog.

Most current training practice is built upon traditional police and military procedures — a point frequently made but rarely written down (several sources are given in GICHD, 2001). Perhaps the most central principle applied here is “our techniques work, so why change them”. It seems likely that introduction of shaping to train mine detection dogs will be by new training organisations, rather than by established organisations.

All of the organisations studied here successfully produced good mine detection dogs. Thus the principle that their procedures worked was supportable. The potential benefits of alternative or new methods may be found more in optimising issues such as response-generalisation and dog hand-over, than in the original conceptual approach for this study of attempting to identify methods that are “better” for training dogs in some absolute sense.

### *Information flow within organisations*

The processes of recording, developing and circulating know-how within each organisation were extremely variable. In an age where competition and the requirements for know-how are high in business, it seems likely that those involved would make high demands for conservation and development of their own knowledge. However, this was not the case in the organisations studied. The procedures used by each organisation for training of trainers and handlers are reviewed in Table 2. The Table is necessarily a limited first attempt, but gives a picture of the observations made and areas that can be improved.

**Table 1**  
**Methods and procedures used by different MDD training organisations**

| Training procedure  | What is achieved?   | Strengths and weaknesses  |
|---|---|---|
| <p><b>Forward chaining:</b></p> <ul style="list-style-type: none"> <li>Step by step the dog is taught the elements and components of a series that eventually makes up a complete, independent chain of behaviour.</li> <li>Each element is reinforced and linked to the previous element so that the chain is built up from initial response training to a complete result. The trainer uses prompts to encourage reactions from the dog.</li> <li>Aid-mechanisms are used either to boost this reinforcement or to strengthen responses.</li> </ul> | <p><i>The dog-trainer</i></p> <ul style="list-style-type: none"> <li>Controls the formation of each link in the behaviour chain.</li> <li>Controls the building of the whole chain.</li> <li>Knows all the details in the process of teaching each element.</li> </ul>              | <ul style="list-style-type: none"> <li>Generally the dog receives many stimulants (rewards) during the training and it can be difficult to cut these out or transfer them to others who take over the dog.</li> <li>The dog becomes dependent on these stimulants during training.</li> <li>The dog deliberately makes mistakes in the hope of getting encouragement.</li> <li>It is a lengthy process.</li> <li>Changing trainers is difficult.</li> <li>Hand-over training becomes expensive.</li> <li>Each step in the training is under full control.</li> <li>Reward generalisation.</li> </ul>            |
| <p><b>Backward chaining:</b></p> <ul style="list-style-type: none"> <li>Final phase – a command is linked to the previously established behavioural sequence. Words or commands are the final link in a behaviour-chain training process.</li> <li>The remainder of the chain becomes a natural part of the final behaviour.</li> </ul>   | <p><i>The dog-trainer</i></p> <ul style="list-style-type: none"> <li>Has full control of each link in the chain.</li> <li>Has control over the build up of the behaviour-chain.</li> <li>Knows every detail of the training process including the intermediate elements.</li> </ul> | <ul style="list-style-type: none"> <li>Normally the dog receives many rewards during training.</li> <li>The dog becomes dependent upon the rewards given during training.</li> <li>The dog may deliberately make wrong identifications so that it can achieve a reward.</li> <li>Problems occur when trainers are changed.</li> <li>Response generalisation is essential.</li> <li>Each training step is time-consuming.</li> </ul>   |
| <p><b>Shaping:</b></p> <ul style="list-style-type: none"> <li>The dog's natural behaviour is reinforced by means of clicking/whistles.</li> <li>Desired behavioural trends are selected by means of rewards.</li> <li>Desired behavioural trends are focused by means of rewards.</li> <li>Desired behavioural trends are steered toward a final objective by directing the rewards.</li> </ul>   | <p><i>The dog</i></p> <ul style="list-style-type: none"> <li>Controls the training process.</li> <li>Gives stable responses.</li> <li>Is an active and relatively independent participant.</li> </ul>   | <ul style="list-style-type: none"> <li>Easy hand-over.</li> <li>Stronger response generalisation.</li> <li>Relatively stable generalisation.</li> <li>Relatively independent of handlers.</li> <li>Repetition and re-training relatively complicated.</li> <li>Requires trainers to have a lot of know-how and observational abilities, etc.</li> <li>The dog's behavioural repertoire may be curtailed.</li> <li>Dog must be highly active from start.</li> <li>Dogs are subjected to unnecessary behaviour to begin with.</li> <li>The trainer must be able to master the art of ignoring the dog.</li> </ul> |

**Table 2**  
Processes used in different organisations for influencing training methods and teaching of trainers and handlers

| Type   | Organisational practice  | Strengths and weaknesses   |
|--|--|--|
| <p><b>Know-how</b></p> <ul style="list-style-type: none"> <li>Conserving and developing know-how in a systematic fashion.</li> </ul>   | <ul style="list-style-type: none"> <li>Document own methods.</li> <li>Have methods for curtailing "private practice".</li> <li>Wide and active evaluation of training behaviour.</li> <li>High degree of experimentation in methods and training behaviour.</li> <li>Publish procedures and results.</li> </ul>  | <ul style="list-style-type: none"> <li>Pragmatic approach when choosing methods.</li> <li>Jump from one to another to achieve knowledge and recognition.</li> <li>Strategic supplier of know-how during hand-over.</li> <li>Blind others with science.</li> <li>Experiment.</li> <li>Consider themselves to be best.</li> <li>Actually contribute to know-how development</li> </ul>   |
| <p><b>Private practice</b></p> <ul style="list-style-type: none"> <li>The individual trainer has a monopoly on central information and practical details.</li> <li>Those in the know hand over knowledge to those who join the organisation in a senior – junior relationship.</li> <li>Management does not demand documentation and reporting.</li> <li>Management and administration are divorced from the actual practice.</li> </ul> | <ul style="list-style-type: none"> <li>Document own methods in practical descriptions.</li> <li>Documentation lacking. Word-of-mouth descriptions ("This is how we do it."). "Rituals" especially during tests or competitions. Boasting ("You should have been there when he/she did...")</li> <li>Chosen seniors who are considered as oracles.</li> <li>Experimentation with established methods low.</li> <li>Established methods are good enough (If it ain't broke, don't fix it!).</li> <li>Management does not ask for documentation and reports.</li> </ul> | <ul style="list-style-type: none"> <li>One-dimensional, conservative choice of methods.</li> <li>Difficult to hand-over knowledge to unknown cultures.</li> <li>Management does not know what is happening.</li> <li>Methods are developed formally and informally</li> <li>The method is carried out in practice according to the best "story-teller", independent of management.</li> <li>Management is kept in the dark and has virtually no practical influence.</li> <li>Sub-cultures and cliques abound.</li> </ul>  |
| <p><b>Drill</b></p> <ul style="list-style-type: none"> <li>Management fully aware of what is going on.</li> <li>Management decides how practice is done.</li> <li>Management decides and controls details.</li> <li>All roads lead to Rome!</li> </ul>   | <ul style="list-style-type: none"> <li>Manager's word is gospel.</li> <li>Those who obey remain.</li> <li>Internal support.</li> <li>Competition clearly identified.</li> <li>Management and practice have no influence on each other.</li> <li>Practical workers receive no feedback.</li> <li>Personal responsibility.</li> <li>Faults and non-achievement blamed on those doing the practical work.</li> </ul>  | <ul style="list-style-type: none"> <li>Can appear to be sectarian.</li> <li>Non-conformance and opposition not tolerated.</li> <li>Only those who "fit in" and are willing to copy are recruited.</li> <li>Methods remain unchanged.</li> <li>Lack of experimentation and new thoughts.</li> <li>Strong bonds between members.</li> <li>Efficient production organisation.</li> <li>Efficient once "correct method" has been found.</li> <li>Difficulties arise when transfer to new persons or groups is necessary.</li> <li>Does not take care of own members.</li> <li>Spawns "private practice".</li> <li>Know-how is not collated centrally within the company.</li> <li>Can achieve good results because of strong individual activity.</li> </ul> |



System research shows that organisation within a company has a large influence on the development of training methods and programmes (Cardillo, 1994; Skovholt and Rønnestad, 1992). Therefore the organisational culture is central to training success, as well as influencing the ability of the organisation to record, maintain and use its cultural (information) heritage. All the studied organisations are “competence-companies”, in that their product was consistently of good quality. But they do not appear to have established strategies to safeguard information (or competence) as a vital aspect of their activity. As a minimum, addressing these issues would involve:

- Ensuring the recording of internal knowledge;
- Ensuring the development of internal knowledge;
- Monitoring the external transfer of knowledge;
- Avoiding “private practice” within the organisation;
- Showing flexibility when transferring know-how to local entities;
- Ensuring that training needs of own staff are regularly investigated; and
- Actively pursuing the further development of staff.

## Principles of practice

### *Trainer and handler abilities*

- There was little or no discussion about what criteria define a good handler or trainer. Either you are or you are not. Nevertheless, those factors that make trainers and handlers good or bad could be established.
- Those who train and develop others become valuable sources of experience and knowledge — they are a central source of competence in the industry.
- Procedures for transferring that competence should be carefully developed and clearly described. Development of a course structure is just one component of that process, as there is also a central need to adjust course content and style to the needs of the students. In this industry, those adjustments may include adjustment for cultural and language differences. A formalised analysis of teacher competence will also help this process.

The abilities central to successful training are “process-abilities”, i.e. the micro-abilities that a person exhibits during a training process. Examples are: use of the voice, motions, gesticulation, hand guidance, the ability to lead the process, self-administration, suffer criticism and correction (and be able to differentiate these two), withstand resistance, suffer frustration, accept one’s own shortcomings and be able to criticise oneself. Further, the person must be able to make observations, turn those observations into constructive hypotheses, form strategies, carry out training and evaluate and learn from the results.

Other relevant abilities include:

- The ability to “read” the surroundings;
- Knowledge and practical experience about mines, explosives, etc.;
- How to manage local circumstances;
- The ability to instruct others.

What is required to train a dog-handler? Before creating a teaching programme the following questions should be answered:

- Which abilities and characteristics must or should a good handler have?
- Which factors are important when training dogs?

A checklist of abilities and competence was developed as a preliminary tool to identify strengths, weaknesses and shortcomings in a person's competence as a dog trainer (Annex 5). During the development of this list, attempts were made to arrange ideas and concepts expressed by those working in this field.

The tool refers to a range of abilities. *Process abilities* can be learnt and acquired relatively quickly. *Personal abilities* need a longer time to incubate and special teaching techniques are necessary to develop them. The area of competence that takes the longest time to inculcate in a person goes under the title of *progressive abilities*. Any teaching programme should address these areas of competence.

## Summary and conclusions

Three main areas have been examined and analysed in this report: the training methods used for mine detection dog training; the influence of the organisation on the choice of method, testing and development; and finally expertise and the development of know-how in field operators. The message from the case studies is that there is considerable potential for improvement in the industry.

Practice in the MDD business has expanded rapidly during recent years. It is time to stabilise that practice in both form and function within a framework that establishes long-term records, and builds objective training procedures.

The training of MDDs is not a magical process. Dogs are trained systematically and repetitively over extended periods, and the overall principles for the training of dogs and personnel are relatively easy to describe. However, integrating researchers into the industry is difficult, and was not achieved successfully within the limited period of this study. The industry made NOKSH welcome but were concerned about how the information was to be used. Thus, the method of exploratory investigation had its shortcomings. Greater success would likely be achieved using the anthropological technique of long-term integration with the culture being studied, because the practitioners were not used to writing down the information, know-how was locally based, and was generated and maintained orally.

## References

- Cardillo, J.E. (1994)  
“Goal Setting, Follow-Up, and Goal Monitoring” in T.J Kiresuk, A. Smith & J.E. Cardillo (eds.) *Goal Attainment Scaling: Application, Theory, and Measurement*, Lawrens Erlbaum Associates, New Jersey.
- Catania, A.C. (1992)  
*Learning*, Prentice Hall, New York.
- GICHD (2001)  
*Designer dogs: improving the quality of mine detection dogs*, GICHD, Geneva.
- Kazdin, A. E. (1994)  
*Behavior Modification in Applied Settings*, 5th ed., Brooks/ Cole Publishing Company, California.
- King, J.E., R.S. Becker and J.E. Markee (1964)  
“Studies of olfactory discrimination in dogs: (3) ability to detect human odour traces”, *British Journal of Animal Behaviour*, 12 (2-3):311-315.
- Schon, D. (1987)  
*Educating the Reflective Practioner*, Jossey-Boss Publishers, San Francisco.
- Skovholt, T.M., and H.M. Rønnestad (1992)  
*The evolving professional self. Stages and themes in therapist and counselor development*, Wiley, Chichester.

---

## Acknowledgements

Thanks go to Norwegian People's Aid (NPA), Global Training Academy, Humanity Dog and the Fjellanger Dog Training Academy for their support of visits made to their organisations. The individuals who directly supported those visits were Geir Bjørsvik, Dan Hayter and Rune Fjellanger, but many other staff contributed their time with enthusiasm and patience. Their participation is acknowledged with thanks. Other individuals and organisations who contributed directly or indirectly to the study were Conny Åkerblom, Theo van Dyke, Ian McLean, Kip Schultz, Alan Sims, Mechem, the Mine Dog Centre (South Africa), participants in meetings of the GICHD MDD Advisory Group, and staff at the GICHD.

---

## Annex 1

# System and practice at organisation N1

N1 is producing contracted dogs for operations in a second country as part of a broader objective of developing a centre of excellence for training MDDs. The company has been breeding and training dogs for a variety of service roles for many years. It has produced a small number of MDDs in the past, but its current contract represents a new initiative and an expansion of their dog production capability. The local climate at the home training centre for this organisation is considerably different from that in the country to which the dogs are shipped (or in most situations where MDDs are likely to be deployed), and time for climatic adaptation is a factor that the company must build into its training programme

NOKSH AS visited N1 for four days, on 25-28 March 2001.

Training generally begins when the dog is 16-18 months old. One person carries out a mental ability test of the available dogs. When this evaluation is complete the dogs are handed over to the trainers.

There is no formal, written procedure or description of the methods for training the dogs. Training is adapted to each individual dog and the transfer of know-how between trainers is done verbally. Whenever possible there is an attempt to match the dog to the trainer. Training of the dogs at N1 goes through several phases.

**Phase 1:** building a relationship and preliminary training. When a dog has been allocated to a trainer, work with building up a relationship is commenced. It is emphasised that a satisfactory and close relationship between dog and trainer is one of the essential factors if success in later training of the dog is to be achieved. During this initial period the trainer carries out everyday activities with the dog — going for walks together, getting to know the various characteristics of the dog, testing the limits of the relationship, finding out how the dog reacts to other dogs, etc. During this phase, standard everyday basic training is also carried out.

**Phase 2:** establishment of identification response. This response consists of both “seek and sit”, and odour discrimination, which present two distinct training objectives. The objectives can be trained in either order, or in parallel. The dog receives considerable help from the trainer during this phase, through the use of gestures, verbal prompts, food rewards, toys and by leading the dog to the target and encouraging it to sit. The identification response is taught in a laboratory environment using Trotyl (pure TNT) under controlled environmental conditions. The Trotyl is presented using scent boxes, which are small semi-sealed containers with a small hole in the top into which the Trotyl is placed. Ventilation is closed off to provide as little air movement as possible. Handling of the explosive is done under near-sterile conditions.

Control over the dog is exerted by using incentive mechanisms:

- Rewards/praise and continuing to strengthen the relationship;
- Varying the incentives e.g. rewards, ball and playthings; and
- Encouraging the dog to respond to low-intensity incentives, such as voice and calm massage.

Low intensity incentives are used to maintain precision, as described below.

**Phase 3:** At this stage, the dog understands what it has to search for, and can carry out the search pattern for reliable search periods. The trainer then works to improve the structure of the search. In addition, a form of generalised training is started involving more natural and varied surroundings, examples of which are new environments, a different type of land area, and human odour on the target. At the same time the help given to the dog is gradually decreased.

A minimum of assistance is given to the dog in those areas where it manages alone. It is critical during this period that the trainers must be able to immediately evaluate the dog's ability and make adjustments to both their own and the dog's behaviour.

**Phase 4:** From now on the dog receives repetitive training and is exposed to natural challenges to further improve its abilities. The main element throughout this phase is establishment of a correct search-structure.

### *Important findings from N1*

**Relationships.** Several people underlined the importance of the relationship between trainer and dog and considered it to be the foundation of the training. This was evident both when the trainer addressed the dog and during the training interaction, for example by how the voice was used and through constant contact with the dog.

**Precision.** The training group emphasised that precision in the search was more important than speed and results. They justified this by saying that the dog must never overlook or forget the position of mines during the search. This attitude to precision resulted in the searching dogs having relatively small movements of the head, generally not exceeding the width of the shoulders. This movement pattern was considered to be the ideal search. The trainer's ability to create low-stress working conditions during the search was emphasised as being another main element in successful training.

**Combination of forward-chaining and shaping.** The methods employed are mainly combinations of forward chaining (building a behavioural sequence by linking a series of separately trained behaviours), and shaping (adjusting natural or created behaviour patterns by using positive reinforcement). Timing of reward presentation and linking the use of incentives to other contingencies (such as voice commands) were central during practice sessions.

More detailed descriptions of the technical terms used above can be found in Chapter 1, Parts 2 and 3.

**Adapting to local conditions.** None of those present, either during training or prior to delivery of the last dogs to the user country, was briefed about the local conditions

or challenges the dogs would face. One of the trainers summed up the working conditions in the country where the dogs were going as at the limits of what animal-rights legislation would permit. At the same time, wishes were expressed for other types of adaptation procedures to prepare the dog for local conditions. One example could be that the local person destined to be the operational handler could spend some time at N1 before the dog was shipped out. One of the trainers made an important point: successfully trained dogs could perform badly in the hands of a different handler because the operational conditions for the dog are not ideal. The reason is that even excellent trainers have a tendency, albeit unwittingly, to make allowances for weaknesses in the dog, and in some cases overlook them completely.

**Practice.** After Phase 1 it is up to individual dog handlers, in consultation with the remainder of the team, to draw up the programme for training their dog(s). Reports are made every month to the management and daily feedback and evaluation of everyday life is carried out within the trainer group. This can result in a form of private practice where the individual trainer and the group develop the style and the practice that suits each dog and the handler in question.

**Generation of knowledge.** The organisation aims for step-by-step development of the trainers. Those recruited to the group are first aspirants, thereafter trainers, and subsequently senior trainers. Finally one can become a team leader with one or two aspirants, one or two trainers and one senior trainer.

It is within this group that knowledge is generated and interchanged. Knowledge is passed by word-of-mouth in a traditional teacher-student fashion. However it was apparent that each trainer had to establish his or her own individual training style — there was little evidence of “structured learning” within the organisation.



## Annex 2

# System, collation of knowledge, and management at organisation N2

N2 is a company that has established itself as a supplier of fully trained MDDs in a number of deployments. It has been producing MDDs for humanitarian purposes for more than ten years, and has been a leading player in the development of the operational search techniques used currently by many organisations.

A three-day visit was made in early November 2000. On the first day NOKSH was with a large group who were given a general presentation, a part of which was a visit to a nearby airforce base with a dog training school and demonstration of dog skills. The large group received an introduction to organisation and production techniques, including three demonstrations:

- Demonstration 1: training up search-responses to micro-concentrations of odours.
- Demonstration 2: basic instruction and incentive training.
- Demonstration 3: box-work and preparing the dogs for realistic field work.

On day 2, a small group was given more detailed demonstrations on both basic and maintenance training at N2.

Day 3 was organised as an intensive review for NOKSH AS, and covered the following:

- The use of laboratories and establishing basic search-responses;
- Talks about details and practice of transfer training to local dog handlers and delivery of trained dogs; and
- Detailed demonstrations of dogs in training.

The visit gave a clear picture of N2's operational structure and training methods for training MDDs and the training of local handlers. The dogs are mainly trained with a combination of forward chaining and prompts (help stimuli, such as voice, gestures, light pressure with hand). These stimuli are used as aids to maintain a high level of intensity, which must be established before transfer to the operational handler of the dog.

The normal incentives are “kongs” (a rubber ball on a short throwing rope), balls and rag-balls, used at a relatively high intensity from the onset of search-response training. Small boxes with trigger mechanisms that contain odours of explosives are used to develop the link between the reward (toys) and the stimulus (odours). The triggering can be adjusted to the search-response of the dog. The dog searches among several small boxes on the ground, which contain different odours and various playthings (kong, ball etc). When the correct box is identified by the dog, a ball, rag-ball or other plaything is ejected. The dog is released and goes after the plaything. Sometimes the plaything is given directly to the dog by the trainer. The trainer then starts to play fetching with the dog at a high intensity for a short period. On command or prompt the dog is taught to drop or sit-drop.

It was underlined by the trainers that the dogs were always trained to give responses to gunpowder in addition to the other explosives/chemicals.

This training takes place after the dogs have received basic training in laboratories where each individual dog is taught to respond to odours from single, isolated sources. The dogs then go through a repetitive drill where they are introduced to varying environments and different degrees of difficulty relating to duration, depth, type of earth, packaging and various forms of stimuli.

A detailed manual for training local handlers and transfer of dogs has been developed, and a basic training book for dog handlers has been drawn up for operational work. The leader of the organisation spent several hours going through the transfer training with NOKSH. He emphasised that only a few people had been given access to that information.

The transfer training lasts a minimum of four months. The details given in the transfer procedure spread from selection of dog-handler to drilling and handling of the dogs. In summary, this detailed procedure covers instruction, control and conformance to a quality standard laid down by N2.

## Annex 3

# Process and collation of knowledge at organisation N3

N3 is a small company that has been training dogs for a variety of service roles for more than ten years. An important component of its business income is obtained from group classes for people with new dogs, starting with puppy classes, and moving on to standard obedience training and socialisation. The company has not previously trained dogs for mine detection, but it has trained dogs for other detection roles, and the owner of the company previously trained mine and explosives detection dogs in the armed services.

Four sessions of interviews and observations were carried out at the organisation's training centre, over a period of one year (2000-2001). The interviewees were the organisation's manager (who is also a trainer) and trainer. Observations of dog training were made under standard training conditions.

The interviews were extensive and covered such subjects as background in multi-choice training, multi-choice methods, discrimination training, maintenance and generalisation, transfer to other individuals of skills and know-how and trainer/dog handler abilities.

The themes and main questions were drawn up in advance. The first two interviews were used to establish and highlight the current situation and were carried out before the formal start of the GICHHD study. The final two interviews were carried out during the spring of 2001.

Initially, the work consisted of describing in detail the behaviour of both the dog and the trainer, and the various phases of a complete process (from selection to a fully trained dog). The approach was revised in accordance with comments made by the client (GICHHD) at the meeting held at Sandø in October 2000. Advice from the MDD Advisory Group was that some of the details being gathered were "over-elaborate". It was thought that the depth of detail could stifle any variation in the present system — in effect it could become a standard that must be adhered to. Another comment was that the Advisory Group had not commissioned a cookbook.

### *Practice at N3*

**Training.** Training is carried out in a systematic fashion and includes registration, computerised documentation and log keeping as a standard part of the procedure. The dogs are trained systematically by means of shaping procedures (see above), being taught to respond to and differentiate between scents according to a randomised trial and error system. The practice includes a gradual increase in the number of different scents, thus increasing the challenge to the dogs.

Initially the training takes account of the dog's inherent seeking abilities, i.e. reconnaissance rather than precise seeking. When the identification and confirmation response is established (i.e. the dog has actually found and confirmed a scent) then, depending on the strength and situation, a repetitive and detailed training procedure is implemented. Each dog is treated individually and its inherent characteristics are taken into account.

The training is carried out so as to avoid strong bonding between dog and trainer (contrasts especially N1). The reason for this is to facilitate generalisation and to make handing-over easier. It avoids the dog becoming too accustomed to a single trainer's body language, gestures, habits and general behaviour.

All training substances are sterile, equipment is cleaned frequently and one-time gloves are always used.

When the dog exhibits seeking stability and endurance, the programme is extended to include structured searching. Simultaneously, variation in the training context is introduced and generalisation training begins (see above). No assistance is given to the dog when it can be shown that it can cope on its own.

### *The development of know-how at N3*

The background for some of the training and equipment at N3 can be traced to a visit to Lackland Air Force base (Texas) in 1980. During a study trip there, the director of the company was introduced to a so-called "scent-board" by the then manager of the veterinary service, Dr. Dan Craig. In essence, this was a wooden plank with holes drilled in it. The scent that the dog was to identify was placed in one of the holes and other scents were placed in the other holes. The dog was then led in and instructed by means of gestures, etc., in what it was supposed to do. During the early 1960s, an article was written about fingerprints and human scents that could be used as indicator factors in a similar fashion to "scent-board" training (King, Becker and Markee, 1964).

With this background, a cooperation was entered into with the local police department (1983/84) where a similar training method was used and where the equipment consisted of tins fixed to a chair. Here the dogs were led to the boxes and instructed to sit.

As time passed, this method was publicised and was immediately criticised by dog trainers. In those days it was considered to be virtually impossible to train a dog in this type of search-behaviour unless it was subjected to a high degree of motivation by the trainer in the form of playing with rags, violent gestures and a lot of masculine activity. In addition, experts believed that there were no alternatives to the established method of hiding the source of the scent in balls, etc.

### *Evolution of training principles at N3*

During the last 15 years the N3 organisation has made two significant changes to its training principles.

- The first concerned the development of a training method that involved use of boosters to control the dog's behaviour. Instead of being led to the source and then instructed on how to react, the dog's own behaviour was used as a starting

point and then manipulated using reward-based learning, allowing the dog itself to find the desired training outcome.

- The second was when the trainer's role was changed from being a highly active and continually motivating driving influence to that of being an observational evaluator and minimally involved component of the learning process.

Other basic adjustments included:

**Apparatus.** This is now matched to the seeking abilities of the individual dogs so that it increases the efforts of those with a low-activity level and reduces the excesses of dogs with a high level of activity.

**Logging/registering.** The dog's abilities, progress and faults are now continually monitored and recorded, with daily and weekly reviews of the data.

**Procedures.** Most of the procedures for selection and training programmes are documented. The dogs are trained mainly using a shaping procedure where whistles and clicking are used as secondary boosters to influence the dog's own behaviour ("clicker training"). This is in many aspects the opposite of normal stimulus-generalisation, which usually relies on the presence of the accustomed stimulants during hand-over and generalisation.

**Discipline "cross-pollination".** Several persons with different expertise and experience are working together on the challenges related to the training of specialised search-dogs.

### *Important findings of N3*

**Systematic training.** The training of specialised search-dogs at N3 is carried out systematically and with a high degree of documentation. This systematic training is subject to a continual evaluation and is shared by the two trainers. Video recording of behaviour, direct observation of each other, and the use of a one-way mirror, ensure systematic feedback and flexibility in the programme experienced by each dog.

**Reduction / control of "private practice".** By systematically monitoring and evaluating the training behaviour of each trainer, it has been possible to significantly reduce the incidence of "private practice". However a certain amount of work remains in this area because manuals for trainer-behaviour are not yet prepared. The company is in the process of publishing the results of its training programme in the international scientific literature.

**Response generalisation.** The training method, the placing of emphasis, and the way the trainer relates to the dog and the everyday circumstances, are designed to reduce dependence and facilitate hand-over and generalisation. Training using systematic response-generalisation from the beginning causes the dog to be much less dependent on surroundings, situations, and personalities when working and exhibiting suitable responses.

**Equipment and development.** The equipment and facilities are fifth generation. The equipment is suitable for leading and moulding the dog's search under the eyes of the trainer. The facilities have been adapted to the task and include one-way mirrors and shields, allowing the trainer to be removed from the learning situation.

**Trainer instruction.** N3 emphasises the requirement for trainers to have certain abilities and characteristics so that they can carry out the training in an appropriate fashion. N3's trainers must:

- Be able to express themselves assertively by means of body language;
- Have good coordination and movement control;
- Be able to observe and understand dog behaviour under various circumstances and then collate this information in a single process of evaluation;
- Be patient and able to cope with variations in the way a dog behaves;
- Be able to avoid pressuring or controlling the dog;
- Be able to control and use their voices appropriately during training;
- Avoid using threatening signals to the dog;
- Be able to anticipate the reactions of dogs;
- Be able to observe and interpret situation changes (progressive leaps in behaviour) during dog training;
- Obey instructions;
- Have an interest in training theory and understand and cope with continual/intermittent reinforcement in practice;
- Be open for suggestions from other professional/practical sources;
- Not act as if they know it all;
- Be approachable and able to carry out self-evaluation and development;
- Be able to accept criticism.

In the opinion of N3, these characteristics and abilities must be present in trainers, albeit in varying degrees, or be learned under practical training circumstances.

**Development of know-how, documentation and professional “cross-pollination”.** Training, planning and performance at N3 are well documented and form part of the internal system for know-how development. Over the last five years most of the organisation's resources have been expended on developing training methods adjusted to the dogs' search-structure, and improving and adapting equipment, all of which is well documented. The company underlines the importance of professional “cross-pollination” well supplied with information on the related activities.



## Annex 4

# Organisational requirements at N4

N4 is a large organisation that operates humanitarian programmes in many countries. Demining forms only part of its operations, although it now uses dogs in most of its demining programmes. It currently uses dogs in three countries, and is progressively upgrading its dog operations. It has experimented with different ways of acquiring dogs, ranging from purchase of fully-trained mine detection dogs, to undertaking the full training programme in-house. The company is demonstrably proactive in embracing new technologies, and in optimising the procedures for both acquisition and use of those technologies.

An initial meeting on how the organisation could contribute information was held on 29 June 2000. The main conclusion was that gathering of information should be restricted to a few, centrally-placed persons in the organisation.

Four one-day interviews were carried out between 1 February and 4 April 2001. The main source of information was the dog-training manager, who is also second in command of the Mine Unit. The interviews were comprehensive and covered topics such as organisation, specific information and details of projects in Africa and the former Yugoslavia, and a current dog-acquisition programme involving a specific supplier.

### *Important findings of N4*

**Organisational and personal stability.** During the interviews it became apparent that the organisation, and thus the framework for the Mine Unit's work with dogs, is vulnerable. Those taking the lead locally (via the organisation's International Section) do not necessarily have the same attitude and viewpoint towards dog work as the Mine Unit. This represents a significant weakness because it creates uncertainty in those who work with the dogs. It also causes discontinuity and almost certainly discourages those who carry out the practical work.

It was also apparent that the organisation at present is not the knowledge generator it ought to be, considering the enormous amount of information that could be maintained and developed within the unit. At present, knowledge is person-dependent (i.e. exists as undocumented personal experience) and is thus not a part of the organisation's common property. There is also a high turnover of staff. This can only be counteracted if staff remain at N4 and become a part of an accumulated culture where know-how is shared.

**Lack of demands on suppliers.** It was apparent that N4 has an ineffective procedure when it comes to placing specific training and transfer demands on suppliers.

- Contracts with the dog-supplier included no requirement for a description of

- the training and incentive measures that were employed.
- Suppliers were not specifically requested to give details of the incentive-schedules used when training the dogs.
  - Suppliers were not specifically requested to provide information about how individual trainers undertook training and developed their relationships with the dogs.
  - Suppliers were not specifically requested to identify success criteria during the training process.
  - Suppliers were not requested to provide details of the incidence and effects of non-conformance in the training process so that this can be discussed and corrected during transfer.

Although not all of these requirements would necessarily have been agreed to, they had not been either identified or discussed during the contract preparation process.

**The organisation's need for knowledge.** It is freely admitted that there is a need in the organisation for stable, enduring knowledge about the dogs, training and hand-over procedures. At present, know-how is largely a verbal matter and a comprehensive, information accumulating strategy is needed. Many organisations suffer from the same problem.

The process of accumulating empirical, databased knowledge can challenge the established thinking of an organisation, for example, because procedures and information flow through the organisation will be reviewed as a part of the process of accumulation. At the worst, it can threaten the position of the persons who hold the established knowledge and could undermine their importance.

### *Conclusions*

Feedback indicates that N4 is aware of the weak points in their work with dogs. There appears to be a significant need for systematic work on administration and contracting for dog-work. It would also appear that N4 could benefit from a more aggressive strategy in connection with their own methods for accumulating and distributing of knowledge to those who work with dogs.

One of the most important factors would be to record the basic and advanced knowledge used in training and handing-over of dogs to ensure the quality of the process from selection to delivery.

It would be in the interests of N4 to draw up a strategy that, as time goes by, generates practical knowledge that can be retained in the organisation and thus forms a development tool for the future.

## Annex 5

# Skills and knowledge needed when working with dogs

### Scoring:

- 0: poor knowledge and skills — basic education needed based on practice learning.  
 1: below average — specific education needed based on personal goals and practice learning, maintenance and updating.  
 2: good — maintenance, personal and specific goal-setting and practice learning needed.  
 3: excellent — periodic screening, self-evaluation and training in divergent reporting on one's own behaviour needed to keep up knowledge and skills in an active, long-lasting feedback process.

| Task   | Skills and knowledge needed  | Score |
|--|--|-------|
| <p>1. Ability to observe the dog in the training situation.</p> <p><b>Process</b></p>                    | <p><i>Observe own and dog's behaviour on the basis of...</i></p> <ul style="list-style-type: none"> <li>· No precise knowledge of the subject, neither the dog's body language nor the interaction between dog and human.</li> <li>· Observes the dog's body language only.</li> <li>· Observes the dog's inter-relationship with him or herself.</li> <li>· Observes the dog's body language, inter-relationship, how the dog acts, tasks and the training situation.</li> </ul>  |       |
| <p>2. Ability to observe one's own behaviour.</p> <p><b>Process</b></p>                                  | <p><i>Self-observation skills</i></p> <ul style="list-style-type: none"> <li>· Unable to see the connection between one's own behaviour and the dog's ability.</li> <li>· Be able to see the relationship between what he/she does and the performance of the dog.</li> <li>· Be able to analyse how one's own behaviour affects the dog.</li> <li>· Be able to pinpoint one's own behaviour and use it to stimulate the dog.</li> </ul>   |       |
| <p>3. Ability to analyse things that happen as they occur during training.</p> <p><b>Progression</b></p> | <p><i>Analysis</i></p> <ul style="list-style-type: none"> <li>· Can't analyse/understand the relationship between the performance of the dog and those factors that directly affect it.</li> <li>· Analyse events but not able to relate them to one's own or the dog's performance.</li> <li>· Analyse and understand the effects of all events that happen during training but find difficulties in correcting oneself.</li> <li>· Analyse and understand the effects of all events happening during the training situation and have the ability to work within this framework.</li> </ul> |       |

|  |  |
|--|--|
| <p>4. Ability to correct one's own behaviour.</p> <p><b>Process</b></p>  | <p><i>Self-correction</i></p> <ul style="list-style-type: none"> <li>· Doesn't understand the relationship between own behaviour and the dog's performance.</li> <li>· Understands the relationship but can't use it.</li> <li>· Understands the relationship and able to use it if helped by others.</li> <li>· Understands the relationship and is able to use it.</li> </ul>  |
| <p>5. Ability to accept instructions.</p> <p><b>Personally</b></p>   | <p><i>Acceptance of instructions</i></p> <ul style="list-style-type: none"> <li>· Unable to accept instructions.</li> <li>· Accepts instructions but doesn't follow them.</li> <li>· Accepts and follows instructions.</li> <li>· Accepts instructions, checks what has to be done and makes sure that the practical aspects have been understood.</li> </ul>  |
| <p>6. The ability to explain events that happen during training/working situation.</p> <p><b>Process</b></p>                                     | <p><i>Descriptive ability</i></p> <ul style="list-style-type: none"> <li>· Unable to describe what is happening during training.</li> <li>· Can describe but not explain what happens during training.</li> <li>· Can both describe and explain what happens during training.</li> <li>· Can describe, explain and teach others about events occurring during training.</li> </ul>   |
| <p>7. Ability to be patient and wait for the dog to respond.</p> <p><b>Process</b></p>   | <p><i>Patience</i></p> <ul style="list-style-type: none"> <li>· Unable to be patient with the dog, forces the dog to respond or react incorrectly.</li> <li>· Patient to some degree.</li> <li>· High degree of patience.</li> <li>· Is patient and uses this ability to analyse the training situation.</li> </ul>  |
| <p>8. The ability to adjust the voice and body language to the situation, the event and the objective of the training.</p> <p><b>Process</b></p> | <p><i>Use of voice and body-language</i></p> <ul style="list-style-type: none"> <li>· Unable to use the voice (voice modulation) or body language suitable for the situation that has occurred.</li> <li>· Able to a certain degree to use the voice and body language suitably during the situation that has occurred.</li> <li>· Perfectly able to use the voice and body language in a suitable way.</li> <li>· Uses the voice and body language suitably according to the situation and apply them to control the performance of the dog.</li> </ul> |
| <p>9. The ability to set realistic goals for the dog and oneself during the training situation.</p> <p><b>Progression</b></p>                    | <p><i>Choosing targets</i></p> <ul style="list-style-type: none"> <li>· Unable to set training targets for oneself or the dog.</li> <li>· Able to set targets (but not ambitious ones) for oneself and the dog.</li> <li>· Able to set ambitious, but realistic targets for oneself and the dog.</li> </ul>  |
| <p>10. The ability to correct undesired behaviour from the dog in a balanced and suitable fashion.</p> <p><b>Process</b></p>                     | <p><i>Reduce unwanted behaviour from the dog</i></p> <ul style="list-style-type: none"> <li>· Unable to recognize and reduce undesirable behaviour.</li> <li>· Able to achieve a temporary reduction in unwanted behaviour.</li> <li>· Knows how to correct the behaviour but not able to apply this to the dog in question or later in the process of training the dog.</li> <li>· Knows how to correct the behaviour and is able to apply this to the dog and the later training process.</li> </ul>   |

|  |  |
|--|--|
| <p>11. The ability to reward the dog according to its behaviour.</p> <p><b>Process/progression</b></p> | <p><i>Administration of rewards</i></p> <ul style="list-style-type: none"> <li>· Can't administer rewards at correct time according to the dog's performance.</li> <li>· Can administer rewards at correct time according to the dog's performance and individual responses.</li> <li>· Can administer rewards at the correct time according to the dog's performance and connect this to the overall behaviour of the dog.</li> <li>· Can administer rewards at the correct time according to the dog's performance and able to connect this to the whole behaviour-chain via each step in the training programme.</li> </ul> |
| <p>12. The ability to accept variations in the dog's behaviour.</p> <p><b>Personally</b></p>           | <p><i>Acceptance of variation</i></p> <ul style="list-style-type: none"> <li>· Can't accept variations in a dog's behaviour or the fact that dogs react differently.</li> <li>· Accepts variations on the whole but not individual variation.</li> <li>· Accepts variation, also individual variation.</li> <li>· Accepts variation, also individual variation and has the ability to see this in a positive light.</li> </ul>   |
| <p>13. The ability to avoid threatening signals during training.</p> <p><b>Process</b></p>             | <p><i>Calming signals / non aggressive signals</i></p> <ul style="list-style-type: none"> <li>· Doesn't understand the value of calming behaviour/signals.</li> <li>· General non-threatening attitude but unable to adjust this to individual dogs.</li> <li>· Does not have a threatening attitude, collectively and individually.</li> <li>· Actively uses calming signals during training, knows how the dog reacts and uses this during training.</li> </ul>  |
| <p>14. Interested in learning theory.</p> <p><b>Personally</b></p>                                     | <p><i>Learning theory</i></p> <ul style="list-style-type: none"> <li>· Doesn't know what this is.</li> <li>· Has heard about it but thinks it is for theoreticians, not practical dog training.</li> <li>· Is actively interested in learning theory but not fully able to use it personally.</li> <li>· Able to use learning theory when analysing and planning training.</li> </ul>  |
| <p>15. Ability to share practical experience with others.</p> <p><b>Personally</b></p>                 | <p><i>Sharing practical experience</i></p> <ul style="list-style-type: none"> <li>· Doesn't share with others.</li> <li>· Shares with select few.</li> <li>· Shares with others but doesn't allow own practice to be influenced.</li> <li>· Shares with others, listens to others, accepts advice, tries things out and reports back.</li> </ul>   |
| <p>16. Wants to learn.</p>   | <p><i>Curious</i></p> <ul style="list-style-type: none"> <li>· Shows no interest, knows it all.</li> <li>· Curious but thinks that that he knows most of the answers.</li> <li>· Interested and open for other's knowledge.</li> <li>· Interested, open and tries out others advice.</li> </ul>  |
| <p>17. Ability to use one's own motor skills.</p> <p><b>Process</b></p>                                | <p><i>Motor</i></p> <ul style="list-style-type: none"> <li>· Can't adjust own movement to the dog, situation or event during training.</li> <li>· Can administer rewards at correct time according to the dog's performance and individual responses.</li> <li>· Administers rewards at the correct time according to the dog's performance and connects this to overall behaviour of the dog.</li> <li>· Can administer rewards at the correct time according to the dog's performance and able to connect this to the whole behaviour-chain via each step in the training programme.</li> </ul>                              |

|   |  |
|---|--|
| 18. Able to withstand and accept criticism.   | <p><i>Accepts criticism</i></p> <ul style="list-style-type: none"> <li>· Doesn't accept criticism, calls it bawling out.</li> <li>· Accepts criticism, thinks he/she is being bawled out and becomes dependent on others.</li> <li>· Accepts criticism and acts upon it.</li> <li>· Accepts criticism and has the ability to apply it oneself during training.</li> </ul>  |
| <b>Personally</b>   |  |
| 19. Able to assess one's own progress.  | <p><i>Self-evaluation</i></p> <ul style="list-style-type: none"> <li>· Doesn't evaluate one's own behaviour and how this influences the dog's performance or the situation.</li> <li>· Sees some relationship between own attitude and the dog's performance.</li> <li>· Sees the relationship, unable to do anything about it and ends up with a guilty conscience.</li> <li>· Sees and understands the relationship, does something about it, uses it actively during training.</li> </ul>   |
| <b>Personally</b>   |  |
| 20. Able to control the dog in a suitable manner as the need arises.                        | <p><i>Controlling of the dog</i></p> <ul style="list-style-type: none"> <li>· Can't control the dog.</li> <li>· Can control the dog but reduces its total activity by appearing threatening.</li> <li>· Can control the dog, threatens and gets a "dependent" dog.</li> <li>· Does not appear threatening and maintains the dog's total activity.</li> </ul>   |
| <b>Process</b>  |  |
| 21. Able to leave the dog alone when the situation, event and training method calls for it. | <p><i>Able to leave the dog working alone</i></p> <ul style="list-style-type: none"> <li>· Can't leave the dog alone.</li> <li>· Leaves the dog alone but reduces its total activity with threatening body language.</li> <li>· Can leave the dog alone but becomes unsure.</li> <li>· Can leave the dog alone, is not threatening, and maintains the total activity even when the dog is active and boisterous. Considers this to be positive.</li> </ul>   |
| <b>Process</b>  |  |
| 22. Ability to predict the behaviour and progress of the dog during the training.           | <p><i>Prediction</i></p> <ul style="list-style-type: none"> <li>· Unable to predict dog's behaviour or progress during training.</li> <li>· Able to predict behaviour but can't relate this to training progress.</li> <li>· Able to predict behaviour, relates this to training progress but can't fully use this in practice.</li> <li>· Able to predict behaviour, relates it to training progress and able to utilise this during practical training.</li> </ul>   |
| <b>Progression</b>  |  |
| 23. Ability to understand and assess how the dog searches                                   | <p><i>Searching structure</i></p> <ul style="list-style-type: none"> <li>· Observes but does not understand the differences in recognition, identification and confirmation responses from the dog.</li> <li>· Observes and understands the differences in the above but can't use this knowledge in practice.</li> <li>· Observes and understands the differences and is able to apply this if helped by others.</li> <li>· Observes and understands the differences in search structures and is able to use this knowledge unaided.</li> </ul> |
| <b>Progression</b>  |  |





## Chapter 4 Programme reviews

# Part 1 The Mechem Explosive and Drug Detection System (MEDDS)

*Vernon Joynt*

### Background

Mechem, the South African Government mine clearing company, grew out of the Government Research and Development Council (CSIR) in 1989. The group that developed the Mechem Explosive and Drug Detection System (MEDDS) in 1985 was originally part of the National Chemical Research Laboratories and then called the Applied Chemistry Unit (ACU).

The ACU was one of the groups doing military research and development (R&D) on mines, mine clearance, demolitions, explosives and warheads.

Mechem was set up as a military R&D group but changed to mine clearance when the Southern African wars ended in the early 1990s. Its R&D function has since been moved back into the CSIR.

ACU began doing explosive vapour detection by linking up with the Police Dog Unit, using police and army dogs and dog trainers. Mechem only started training its own dogs when it began doing commercial mine clearance.

MEDDS is a filter tube absorption system. It was first developed to trace smuggled explosives and munitions and most of the basic development work was done for that purpose. When the system was refined to detect landmines, the development group was already a part of Mechem.

MEDDS proved to be very effective in detecting smuggled explosives and drugs, significantly better than both chemical techniques and normal explosive detecting dogs.

This report describes the MEDDS system and the R&D required for its development, and provides some details of its operational track record.

## The MEDDS landmine clearance system

Every landmine and UXO has a vapour signature that includes the vapour given off by its explosive filling and construction materials, such as TNT, RDX, plastic, paint and rubber. These constituents produce vapours specific to each type of UXO or landmine. This signature occurs in the field as a vapour plume or trail of vapours absorbed onto the vegetation, soil and other surfaces. If a detector is able to detect the explosive vapour, then it should be able to find every device, independently of other vapours.

One of the most effective means of mine detection today capitalises on the highly specific and highly sensitive olfactory capabilities of canines. In fact, it is generally accepted that a set of trained dogs is currently the only effective field vapour detector. These dogs can be trained to carry out one of two different mine detection tasks:

- The detection of pure chemicals such as the explosives RDX or TNT. Such dogs are referred to as “Chemical Dogs”.
- The detection of the mixture of vapours, including the plastic, rubber, etc., that makes up the vapour (smell) of the complete explosive device. Such dogs are referred to in South Africa as “Bouquet Dogs”.

The Enhanced MEDDS system (see below) uses off-site chemical dogs. Enhanced MEDDS is a primary or stand-alone detector. Mechem’s present approach is to train national personnel in the theatre of operation to collect vapour samples, which are then screened at a clinically-controlled dog centre using chemical dogs to do the detection. The detection centre is clinically-controlled in order to minimise contamination during handling and processing of vapour samples.

A single chemical dog trained on TNT (Fig. 1) is able to achieve a detection rate of more than 90 per cent, and a team of only three dogs is needed to achieve an effective detection rate (see below). In the U.S., programmes such as DARPA have accepted the Enhanced MEDDS as one of the benchmarks against which to measure their electronic vapour detectors. Sampling vapours into absorbent filters is done both with Mine Resistant Vehicle (Fig. 2) mounted and hand-held suction pumps (Figs 3, 4).

Fig. 1.  
A MEDDS dog indicating a positive sample



Fig. 2.  
A mine protected vehicle



Fig. 3.  
Suction equipment inside the vehicle



Fig. 4.  
A field team with hand operated suction equipment



For an area to be declared clear, only negative results from all dogs indicating that **no explosive is present** are accepted without further checking. Positive results are followed up using other clearance techniques. A labeling system ensures that positive filters can be linked back to the site at which the filter was made.

MEDDS is not a demining method. Rather, it is a system for eliminating areas of land that do not contain traces of explosives or target scent. This is sometimes called an Area Reduction System (see also Fjellanger, Chapter 2, Part 2).

A limitation of the current MEDDS technology is the requirement to transport the samples to the dogs remote from the collection area. Clearly a means for testing the samples immediately upon sampling or at least without a long delay would allow quicker responses in the field. By incorporating the FIDO technology into a MEDDS-type process, rapid detection could be performed. This could be done in lieu of or in consort with dogs, depending on the local situation and requirements. FIDO is the chemical vapour detector developed by the Nomadics Company during the DARPA Electronic Nose Programme.

## Research and development on MEDDS

MEDDS was developed in a research and development environment, yet in the end most of the key elements used in the system came out of field experience. What the R&D culture did was to provide a capability to analyse and refine the field experiences.

At first, for some four years from 1987, there were attempts to do scientific tests, but it was soon clear that:

- When working with vapour detection in operational sites, every test done generated new questions and doubts. Vapour detection of explosives in real minefield conditions had too many variables to make scientifically exact tests feasible. The main problems were:
  - While setting up a test site, local contamination created during that process affected the sampling that followed.
  - Weathering and aging were key elements influencing detection in a real minefield.

- Weathering and aging removed fresh test site contamination, but then introduced random movement of vapour from the real sources.
  - Weather conditions when sampling were a critical factor. In particular, moisture could enhance or suppress vapour detection.
- In this respect it is like ground-penetrating radar, a detection technique that always requires extra tests before you would use it.

Today people are relearning the very same lessons in a series of tests being done in Croatia to determine some scientifically measured detection parameters.

## MEDDS

Mechem made MEDDS work by integrating the sampling over a large area (between 100 and 400 metres of road). Sampling over large areas ensured that the elusive explosive vapour in the approximate area of the buried explosive was detected. A lesson learned was that MEDDS should never be used to try to locate mines directly. In operational situations we only used the technique to do reliable area reduction — and backed up the system with some other position detection technique, such as dogs or manual deminers.

In terms of weather and contamination effects, our experience with MDDs doing direct detection in the field confirmed many of the experiences we had with the filter tube sampling in MEDDS.

### *Chemical tests*

ACU, and later Mechem, did chemical tests in parallel with the MDD and MEDDS tests to try to identify chemical residues being detected by MEDDS. The field dogs gave more similar results to MEDDS than did the chemists.

The chemical tests provided conclusions in line with some of the more comprehensive results now being produced by Sandia and FOI (Phelan and Webb, Chapter 5). The buried mines give off enough vapour, but all of the following factors reduce or move the site at which the vapour appears relative to the mine's position:

- The type of soil;
- The effect of sunlight (UV);
- Moisture exposure;
- Washing water;
- Bacterial action.

We concluded that:

- Vapour detection of mines can only really be considered an *area detector* and should only be used for Area Reduction in mine clearance;
- To make it a *position detector* would be difficult;
- Samples for detection should integrate an area to ensure that some explosive substance indicating the presence of a mine or UXO is collected.

### *Other Mechem tests*

Mechem attempted to use position sampling or a field dog's position indications to track the spread of the vapour, but was not very successful.

Detection was affected by the prevailing wind, water wash according to rainfall, soil type, and also the varying ability of plant leaves to protect TNT against sunlight decomposition. All these factors had an effect when long timescales were present. We had expected to find the TNT would spread out in circles through diffusion over time but this did not happen as the mentioned factors were dominant.

Only right at the beginning of the tests did we indeed find circles. One hour after the mine was laid it was detectable at about one metre, after four hours about two metres, etc. After a month we would get roughly an ellipse down the average wind side or perhaps some other shapes along the side where water washed the TNT away from the mine. Sometimes the mine was detectable up to distances of even 30 metres away, but then it was clearly due to water-wash and wind.

This is why we use MEDDS sampling only on a macro-scale and cover as much area and sample in as many places in that area as possible. This is to make sure we would hit the TNT wherever it has moved to.

### *Detection distance*

If vapour diffused in a homogeneous (i.e. regular) pattern away from the mine, diffusion patterns around the mine could have been used to determine the width of sweeps (with the vacuum device) in area surveys using MEDDS. Unfortunately, experiments investigating patterns of diffusion in the field indicated that the spread was not regular. Experiments using dogs trained to sit at the first whiff of a mine indicated that they occasionally detected mines at distances up to 20 metres (see also Chapter 4, Part 2). MEDDS had been shown to enhance the ability of the dogs to find something. We therefore chose 10 metres as the sweep width at which detection should be reliable. Subsequent results in mine clearance contracts indicated that this choice of 10 metres had been a good one.

The field MDDs used for mine clearing today are trained to react when they are virtually on top of the mine. The accreditation tests for these dogs to qualify in a mine clearance contract usually require the dog to indicate within one metre of the position of the mine. The requirement of indicating within one metre is appropriate if the test mine is freshly laid. However, recently Mine Action Centres have been maturing the test areas first, in some cases for two or more years. Under those circumstances, the possibility that the strongest smell is metres away from the mine position should be considered, as it may be influencing the ability of the dog to find the mine. In fact, during the time we were backing up some of the MEDDS findings with chemical tests done in our laboratories, we had cases where no TNT could be found right above the mine. This happened on more than one occasion with metal body mines.



## Operational results for MEDDS

The decision was to use MEDDS as follows:

1. Integrate large areas by sucking into one Filter Pack: usually 400 metre lengths (all use of MEDDS was on roads).
2. Sweep widths: up to 10 metres to the left and right of the suction point. Thus a width of 20 metres could be done when looking for long-buried mines. One must make sure, however, that sampling conditions are optimum, e.g. work at the right humidity conditions, etc.
3. Trust only tests that return a negative result from all dogs.
4. Use statistics to achieve 99.6 per cent confidence levels (the UN standard at the time).

Justification for the last two points is as follows:

### *Trusting only negative results*

Explosive vapours can be detected on filters even when contamination only is available to the suction machine (i.e. the device itself has been removed). MEDDS can therefore indicate positive even if mines or UXO are not present. This problem applies especially in old battlefields.

However if there are no explosive vapours detected, then the area can be declared mine free.

### *Use statistics to achieve the 99.6 per cent UN standard of clearance*

Training procedures are designed to produce dogs with reliable detection skills. However, it is not expected that each dog will give perfect performance, for example because of daily variation in the skills of the dogs, because sensitivity to particular odours will vary among dogs, or because the available odour on the filter is close to the detection threshold for the dogs. The possibility that some dogs will miss some positive filters on some days is handled statistically. In practical terms, the combined performances of several dogs should give a higher detection rate than each dog will achieve alone if detection failures are not highly correlated among the dogs (highly correlated = two or more dogs miss a positive filter for the same reason). The number of dogs required to achieve reliable detection can be predicted from their individual performances (Fig. 5). The values in this figure were obtained from several empirical sources, including operational work in Mozambique.

The teams were not chosen as such but all the dogs were regularly graded as individuals and the rating then matched with performance. So the red “team” for example, always had only five dogs but through time the individuals making up the team changed and as many as 20 separate dogs were used. The results were grouped to indicate what a certain level of test score would require in terms of numbers of dogs to be used in order to have an acceptable result.

About three years ago Mechem rebuilt its MEDDS capability because the dogs were performing poorly. A new batch of dogs for MEDDS were then trained using more carefully designed procedures, to remove the possibility of the dog learning odours other than those intended. These dogs achieved better than 90 per cent success on

target filters. Using Fig. 5, we predicted that only three dogs were required in a team to achieve the 99.6 per cent requirement of the UN contracts.

Figure 5  
Number of dogs required to achieve 99.6% detection using dog teams giving differing levels of performance

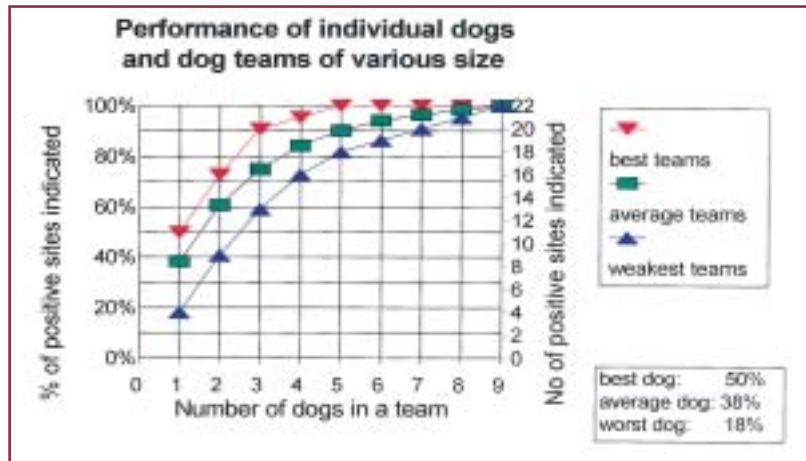

### Enhanced MEDDS

Through the years MEDDS has been improved and we now classify it in two different versions:

- Bouquet MEDDS,
- Chemical MEDDS or Enhanced MEDDS.

Enhanced MEDDS detects TNT only.

Bouquet MEDDS uses dogs that are trained to use all the smells of the mine when they check the filter tubes, as do field search MDDs. All Mechem's operational results quoted here are for this older type of MEDDS.

Enhanced MEDDS is based on training the dogs to react to only one key chemical. In the field tests we used TNT, but it might equally be RDX or a drug such as cocaine.

Individual dogs in Enhanced MEDDS can do better than 98 per cent, in a straight detection test done on the work line. Then it would need only two such dogs to achieve the standard.

### Area reduction

The main value of MEDDS to Mechem in mine clearance contracts is for area reduction. The financial analyses in Table 1 show the important role it played in Mechem's contracts.

| Demining contract  | Contract price | MEDDS area reduction | Value | MEDDS cost | Money saved |
|--|----------------|----------------------|-------|------------|-------------|
| UNOMOZ<br>Mozambique<br>2,000 km road                                  | 5,000          | 40%                  | 2,000 | 400        | 1,600       |
| UNAVEM III<br>Angola<br>4,650 km road                                  | 6,500          | 33%                  | 2,100 | 1,300      | 80          |
| Cahora Bassa<br>MEDDS Survey<br>80 km <sup>2</sup> plus<br>500 km road | 1,000          | 75%                  | —     | 1,000      | 0           |
| Cahora Bassa<br>80 km <sup>2</sup> plus<br>300 km road                 | 7,000          | 15%                  | 1,050 | 500        | 550         |

Figure 6.  
An overgrown road in Mozambique being sampled with MEDDS

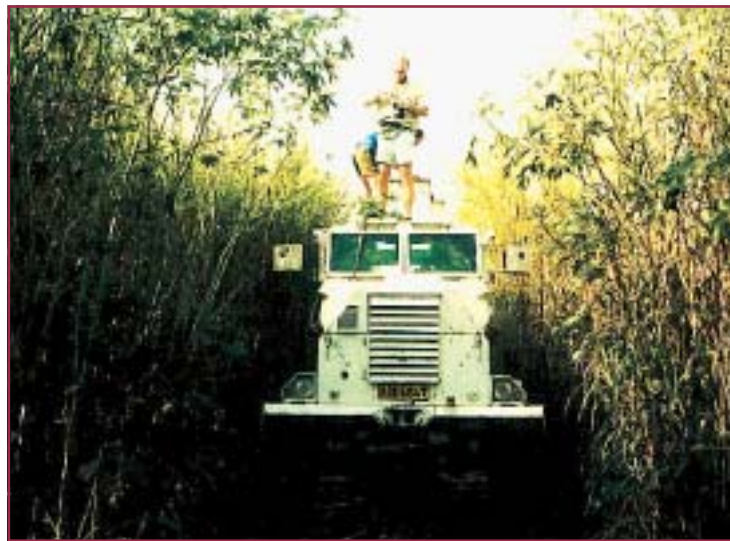

### *Comparison with manual demining*

This photo was taken during one of the re-clearance contracts of roads that were being rebuilt in 1994 in Mozambique. Mined roads are not serviced, so tend to become overgrown.

Most roads in tropical Africa's former war zones have ended up overgrown like this. When peacekeeping forces move in they are confronted with a mobility problem and need to clear these roads.

Manual clearance provides clearance at about 2-4 kilometres per team per week. Using MEDDS and Mine Resistant Vehicles it was possible to do 14 kilometres per team per day — more than 20 times faster.

Figure 7.  
A bulldozer blown up by an anti-tank mine in Mozambique



Some roads were cleared by manual teams in Mozambique immediately after the war ended. Unfortunately, some road building equipment following them was destroyed (Fig. 7). Hand-held metal detectors and prodding sticks were clearing to around 100 millimetres depth, and anti-tank mines are often placed at greater depths.

After these accidents, Mechem was contracted by two different road building contractors to re-clear some roads. Using MEDDS, Mechem found seven missed mines for Murray and Roberts on their 133 km stretch of road, re-clearing this stretch of road in three weeks. For Basil Reed Mining four missed mines were found on 107 kilometres of road in two weeks. Manual deminers originally cleared both roads taking more than one year to do so.

Vapour detection is less affected by the depth at which mines are buried because the explosive odours are carried to the surface by, among other effects, moisture movement (Chapter 5, Part 2). A crust of explosive forms at the surface which is then lifted off as dust and carried by air movement to the surrounding plants, from where it is collected by vacuuming. TNT attached to the bottom of leaves is protected from direct sunlight, and is less likely to be decomposed.

To do these re-clearing contracts Mechem first used MEDDS to eliminate the lengths of road that did not have any mines or explosive vapours present. For those 400-metre stretches of road that showed positive for explosive, the next step was to use field MDDs to locate the mines more precisely. Finally manual deminers searched 10 metres around the spot the dog had indicated.

The MEDDS principle clearly has remarkable potential for use as an area reduction tool. This is its most appropriate use as MEDDS cannot be used to locate or clear mines. It will therefore be used in concert with other demining techniques such as field search dogs and manual demining. It is unlikely to be used before or after machines, because of contamination issues. It is potentially particularly valuable for searching areas that are slow or difficult to access and search using other techniques, such as on steep slopes, in dense vegetation or around trees or constructions. The main restriction on its use is the necessity of carrying the vapour sampling equipment

into the minefield. The best known system for achieving this is a walking person, although protecting that person (actually usually two people) remains an unsolved problem.

Currently, there are numerous mine detection dog programmes working around the world, but essentially none are using the MEDDS principle for area reduction. I hope and anticipate that its use will increase. An important and relevant factor is that MEDDS allows deminers to work only in areas in which they are likely to find a mine. Working in such a situation should reduce the likelihood of mines being missed through inattention and improve safety.

## Chapter 4 Programme reviews

### Part 2

# Preliminary results on the use of *Cricetomys* rats as indicators of buried explosives in field conditions

*Ron Verhagen, Christophe Cox, Robert Machangu, Bart Weetjens  
and Mic Billet*

### Summary

APOPO, a Belgian research organisation, developed the idea of using rodents for mine detection. After exploring potentially suitable species, the African pouched rat, *Cricetomys gambianus*, was selected for this purpose. After an initial research phase in Belgium, the project moved to Tanzania in May 2000. *Cricetomys* rats were trained both in experimental lab settings and on an experimental minefield to recognise explosive odours. Results of a series of tests in the field with nine rats are presented here.

Rats conditioned on TNT were trained to walk lanes in experimental boxes (10 metres x 10 metres) each containing a variable number of mines (0 to 4). The rat processed the whole box by covering 40 lanes twice. An observer took notes on the behaviour of the rat while working. These notes were analysed afterwards to assess the performance of the rats. Concentric circles were drawn on the field maps around the mine with a radius of 0.8, 1.6 and 2.4 metres and all positive indications were mapped within these circles. Specific indications (biting or scratching the soil) within a radius of the circle of the mine was considered to be a hit for which the rat was rewarded by the trainer, while indications beyond the chosen circle were treated as false indications. From this data the success score of the rat was calculated.

On dry days mean success score of the rats ranged from 80 to 89 per cent depending on the evaluation circle chosen. On wet days the success score was considerably lower. There was considerable variation in performance between the free running rats. This variation was used to select the rats most suited to be free running rats. Beside the individual variation in success score between rats, success score was influenced by several external factors. Both increasing humidity and temperature had a negative effect on success score. Success score was also dependent on the number of mines present in a box, being lower when more mines were present. Certain aspects of how to improve the method used are analysed and discussed.



This paper attempts to define the capabilities of *Cricetomys* rats in searching for mines. Although testing of the free running rat is still in an experimental phase, this method might have great potential for the location of mines in suspect areas.

## Introduction

The APOPO organisation was founded in response to the global landmine problem and because many mine detection techniques are comparatively slow and expensive. APOPO's overall objectives are to develop a low-priced methodology for efficient detection of landmines and UXO, to facilitate a reduction in the number of mine victims and to create mine-free land in post-war countries.

The idea of using rodents for mine detection was the outcome of an exploration and analysis of the mine detection problem. The Belgian Directorate for International Cooperation (DGIS) gave its first financial support to develop the concept in November 1997. APOPO vzw was registered under Belgian law as a non-commercial company and started its first experiments early in 1998.

A feasibility study was first implemented in a temporary lab in Belgium. To determine the most efficient way of training and using rats, APOPO tried several methods and methodologies in parallel approaches. One group of laboratory rats was trained to indicate the smell of explosive samples by pressing levers from within a caged set-up; another group of rats was taught to trace and indicate TNT samples hidden in a sandbox.

Meanwhile, APOPO started breeding and socialising African giant pouched rats, *Cricetomys gambianus*, imported from Tanzania, and developing concepts for the use of these animals in the demining theatre.

The promising results of both the training experiments and the breeding programme supported the planned transfer of APOPO's operational base to Africa. This would allow training and testing of the *Cricetomys* rats in near to natural conditions.

During the first half of 2000, APOPO established its premises and training area at the Sokoine University of Agriculture (SUA), in Morogoro, Tanzania. The choice of this location was a result of APOPO's collaboration with the Department of Biology of the University of Antwerp (RUCA), which had a long cooperation with SUA in the field of rodent research. With the logistic support of the Tanzanian People's Defence Forces (TPDF), APOPO has established extensive training and test minefields. Meanwhile, the project still has its Belgian support office at the University of Antwerp.

While APOPO's main objective is the widespread application of its technology, a scientific approach should guarantee the quality of the product and trigger further improvements. APOPO has therefore gained considerable knowledge and experience in rat training methodology and vapour detection, and has designed and developed a

variety of technical devices and olfactometers. Much of this experience and technological development probably has applications for the dog training community. GICHD evaluated the APOPO project positively in May 2001. In May 2002, APOPO was in full preparation for its transition to operational work. The demining community has given a generally positive response to the rat detection technology and some major demining organisations have expressed interest in making new cooperation agreements.

The objective of this chapter is to present the first results on the deployment of *Cricetomys* rats as mine detectors in field situations.

## Why rats?

### *How rats came into the picture*

The idea of using rats for the detection of landmines came from the search for a cheap and efficient landmine detector which would be able to detect both metal and plastic landmines. Metal detectors had enough sensitivity to detect the metallic parts of plastic mines, but were giving far too many false positives. A lot of emphasis and resources were going into the development of ground penetrating radar systems with sophisticated image processing, either handheld or airborne — or even carried into the field by remote-controlled robots.

In reality, the only alternative technology to manual demining that has entered general use since the recent dramatic increase in humanitarian demining activity is mine detection dogs. Moreover, the concept of explosive vapour detection (EVD) was promising, allowing the vapour plume of a landmine to be detected at some distance from the mine — hence the high potential of the REST concept for area reduction (Chapter 2, Part 2).

There have been many studies on the olfactory capability of rats. The laboratory rat is one of the most widely studied animals, so the existence of research on its olfactory capabilities is not surprising. There have been specific attempts to use rats (Nolan *et al.*, 1978) and other rodents (Biederman, 1990) for the detection of explosives and narcotics. The authors claimed very high sensitivity to explosive vapours, high reliability and very long endurance (up to eight working hours per day) — and full training in an automated set-up could be achieved in a matter of weeks.

These characteristics suggest that rodents are good candidates to be mine detectors. Taking into account some of the disadvantages of dogs — such as the high initial cost price, a long and intensive training period and vulnerability to tropical disease — a cheap and easily maintained rat could be a better alternative for the job of mine detection.

## Which rat?

Rodents are the biggest order of mammals, with almost 2,000 species. The choice of which species best fits the requirements was determined by identifying the desired characteristics of a mine detection animal. Essential desired characteristics are very

good olfactory capacity, resistance to tropical diseases, long lifespan, easy to breed and handle, and easy to train and condition. Preferably, it would have to be a wild species, as it was argued that their olfactory capacity would be at peak performance compared with laboratory animals.

The combination of an abundance of mined countries in Africa and APOPO's special focus on Africa meant that it was logical to choose a species that was native and widespread in Africa. Such a species should have the highest chances of having good resistance to tropical diseases.

It would also have to be a docile animal, easily tamed and domesticated — and preferably not too small in size, in order to be able to locate it within the vegetation. The choice was made to use the African giant pouched rat, *Cricetomys gambianus*. Apart from showing the desired characteristics mentioned above, this is one of the few rats with a lifespan of about eight years, therefore optimising the return on the training investment. It has the habit of collecting food which it stores at various places underground and therefore uses its smelling capacity to find its food — behaviour quite similar to the mine detection task. Furthermore, this species was already bred as a pet in the U.S., indicating its potential for domestication.

### *Cricetomys gambianus*

We will take a closer look at the characteristics of the *Cricetomys gambianus* from APOPO's experience.

#### Olfactory capacity

The smelling capacity of *Cricetomys* is very highly developed. Observing the animal, one can notice its nose being constantly very active and moving.

To quantify the rat's sensitivity to explosive odours is very difficult, as the extreme dilution of explosive samples needed in mine detection training renders the content uncertain and very subject to evaporation or contamination. Nevertheless, studies are being initiated that will give an indication of the animal's sensitivity for TNT.

So far, it appears that the sensitivity of the giant rats is satisfactory for both REST and direct location of landmines.

#### Trainability

Since the 1950s, rats have been commonly used for learning experiments and behavioural studies, often in an operant conditioning environment (the so-called Skinner boxes).

APOPO principally uses a combination of click training and food rewarding. Probably the main difference to most dog training is that the rats are not taught obedience. As such, the total training period can be relatively short. In APOPO's experience so far the field rats can be trained in six to ten months, and REST rats in four to six months. Training starts at the age of five weeks, when juveniles are weaned from the mother.

The rats are “smart” enough to learn the desired tasks relatively quickly, while being “uncomplicated” enough for learning to be mechanical and standardised. Food provides a strong and controllable source of motivation and the only effective motivating drive for performance.

Earlier experiments, which claimed up to eight hours of continuous attention in an automated setting (Weinstein *et al.*, 1992), used electric brain stimulation (EBS) or the termination of electroshocks as a motivation. APOPO aims to use individually trained rats for many years for a humanitarian purpose, and uses food rewards strictly. This limits the animals' concentration span to 20-40 minutes, depending on the rewards, the kind of task and the temperature. Recent experiments suggest that rats will work for such a period at least twice a day.

The rats love to execute repetitive tasks, a characteristic that is an advantage for either field search, or for a REST design.

### Size

African giant pouched rats weigh between 0.7 and 1.5 kilograms. The average body length is 30-40 centimetres, excluding the tail of 40 centimetres. A disadvantage of this small size is that the rat cannot be observed in long dense grasses. On the other hand, its small size also offers several advantages.

The housing requirements of the rats are considerably less than are required for dogs. APOPO is housing the animals by two in cages of about 80 cm x 50 cm x 50 cm — allowing 100 cages or 200 rats in a room of 6 m x 13 m. Temporary housing during transport can be considerably smaller, and some dozens of animals could be transported in a terrain vehicle.

In the field, their small size has the main advantage that the rats' nose is always close to the ground, even if the head is raised. The highest vapour concentration and the lowest wind speed are found close to the ground. Their size also gives the animals a good pace for scanning the field. In some situations, their small size will enable rats to reach where a dog cannot reach.

Their low weight makes it highly unlikely they would set off a mine by scratching or pointing — which increases overall security.

### Maintenance

Being endemic to the whole of Sub-Saharan Africa, the African pouched rats are quite resistant to tropical disease. So far, no serious illness has been recorded among the APOPO rats. There have been some individual losses, which can be avoided with the necessary precautions. In a separate study, APOPO is preparing an inventory of all diseases that are occurring in these rats found in the wild. In comparison with dogs, veterinary care requirements are less for the rats.

Food intake is also less than for dogs. The trained rats live mainly on their reward diet, which they earn at the job, consisting mainly of banana and peanuts. Apart from this, they can be fed with grains, maize, carrots, fruits, fish, insects and many other kinds of food. Thus food supply should rarely be a problem.

Rats do not need a daily walk out. APOPO provides a free open run where the rats can play or habituate to the outside environment. Other rats get a free walk in the animal house during clean up of their cages, as they do not attempt to escape.

### Handler issues

In APOPO's experience, all trainers who have been employed to train the animals (mostly Tanzanians) have picked up the training job quickly. There have been no

cases of fear among the trainers, nor cases of mistreating or rough handling of the rats, which could initiate fear in them. In general, we observe quite gentle handling and respectful interaction with the animals.

An important advantage of the rats is their independence from a personal handler. Generally, most rats remain with the same trainer, but show no difference in performance when taken over by somebody else in the absence of the trainer. A rat could thus be trained by several people, or more importantly, be trained by one person and be tested or handled in the field by another. One handler team — consisting of two people — could thus easily operate ten rats consecutively. This also implies that the training of the handlers and the training of the animals can be separated.

### **Cost-related aspects**

An exact cost calculation of the rodent mine detection technology will only be possible after relevant operational field experience over a period of time. A direct comparison with dogs could then be made if a detailed cost analysis for a mine dog detection programme is available.

Though any kind of new technology needs further research and development, the DGIS has already invested in the principal developments and research infrastructure. Both for REST and direct detection, the technology is available to the demining community at no cost.

In our opinion, the biggest cost saving in demining will be made by developing the REST system — which is now limited to roads — for area reduction. Research results from investigating this concept will soon be available.

### ***Field application of the rat technology***

Since the implementation of the project in Tanzania, several experimental set-ups have been investigated, with some proving to be more successful than others. Also, the training method for the rats changed throughout this period, with the main objective being to shorten the training period and increase the performance of the rats. We provide here the first set of results on the use of *Cricetomys* rats for the detection of buried explosives in the field.

### ***Materials and methods***

A series of 10m x 10m boxes were established, each containing a variable number of mines. Rats conditioned on TNT were trained to walk lanes 6m in length in the box and search for buried mines. The animal worked on a leash, which was attached to a glider under a 6m-long bar with a set of spokes at each end of the bar. One turn of the spoked ends gave a search lane width of 0.5 m, which the rat searched twice before the apparatus was rolled for one spoke to establish the next search lane.

A complete search of a box involved introduction of a rat into the corner of a box. The rat processed the whole box by covering 40 lanes twice. On average it took the rats about 28 minutes to complete a box (mean time of 70 boxes inspected).

Two people were present while the rat was working, one at each end of the apparatus. The trainer rewarded the rat when it indicated a buried mine. A reward involved the

trainer clicking, after which the animal moved to the trainer to receive a reward before searching the remaining part of the lane. The second person, the observer, took notes on the behaviour of the rat while working.

The following behaviours were recorded: a **hit** when there was a positive indication, a **miss** when the rat did not indicate the place where a mine was situated, and the frequently observed behaviours **grooming, eating, freezing, sniffing with the head in the air, returning in lane, pulling leash**. When indicating the location of a buried mine the rat showed a specific behaviour such as scratching or biting the soil or a combination of both. If a rat indicated on a spot more than 0.8 m from a buried land mine, this was noted as a **false positive**. For this indication the rat was not rewarded.

We analysed field trials for nine rats for data taken on nine days between 29 April and 10 May 2002. Testing was done between 7.30 a.m. and 10.30 a.m., depending on weather conditions. No tests were done when it was raining.

### The experimental minefield

In the experimental minefield (Fig. 1) there were 120 boxes of 10m x 10m, containing 0 to 4 mines (type: PMN mines). Small lanes (0.5 m) separated boxes where both the trainer and observer could walk. The position of the mines was indicated with coloured poles placed at the borders of the box giving X and Y coordinates. Mines were buried in the boxes between July and October 2001. The depth of the mines was 5cm below ground surface. Vegetation in those boxes was kept short (<20 cm height) by slashing at regular intervals and slashed plants were removed outside the box.

Figure 1  
Map of the experimental minefield with the location of mines in each box

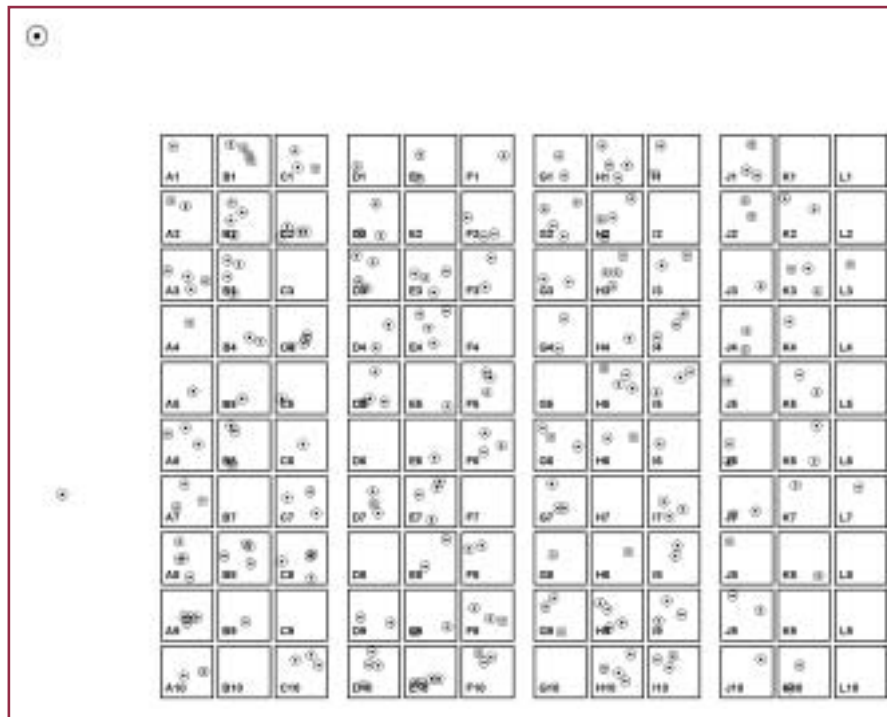



For this analysis data were collected from 30 boxes (columns G-H-I). Each box was searched by a rat about every three days. It was very unlikely that marking behaviour of one rat would influence the next rat because it was an open field with a lot of rat activity at night by wild *Cricetomys* rats. Fig. 1 gives the distribution of the mines in the experimental minefield. From this figure it can be seen that the concentration of mines per given area is variable within the minefield with a mean of 2.4 mines/100 m<sup>2</sup> (calculation excludes safe lanes).

### Analysis of the data

As we are unable to directly measure the concentration of explosives at different distances from the buried mine, it is difficult to tell if a positive indication by a rat is either a “good” hit or a false positive. One can expect a negative relationship between the distance from the place of indication to the mine, and the probability that the indication is a false positive. Therefore we drew concentric circles on the field maps around the mine with radii of 0.8 m, 1.6 m and 2.4 m and mapped all positive indications within these circles (Fig. 2).

Figure 2

Map of box G4 with two mines surrounded with evaluation circles and the different behavioural patterns of the rat Apoc (S=scratching which is an indication; G=grooming; P=pulling string). The upper mine is scored correctly close to the actual position. For the lower mine there are indications at a distance of 2m from the mine, these indications are not considered as hits by the trainer and consequently the rat gets no reward. However, the interpretation afterwards shows there is a good possibility that it is a positive indication. The S in the lower right corner is clearly a false positive when one only considers its position within this box. When looking at Figure 1 one can see that this indication is close to a mine in the left upper corner of box H5.

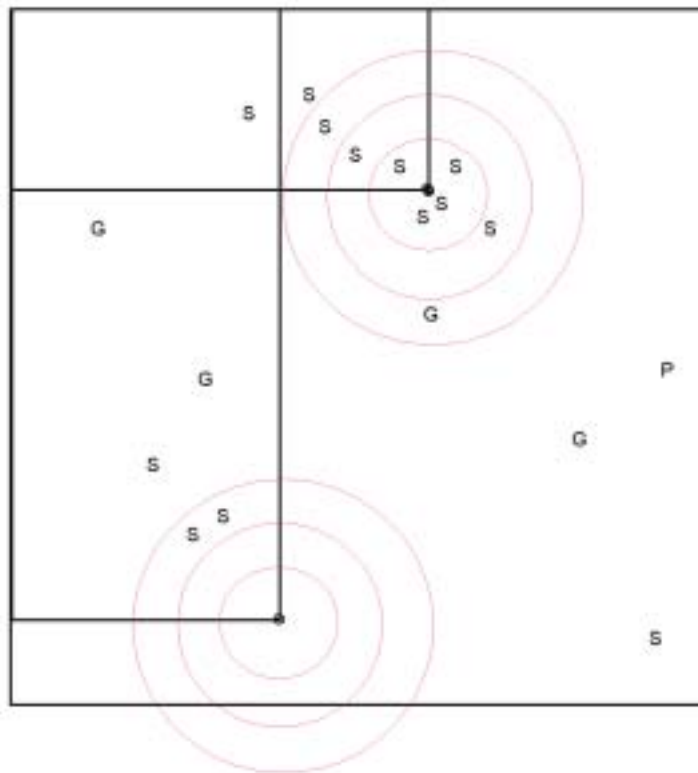

Each indication within a radius of 0.8 m of the mine was considered to be a hit, for which the rat was rewarded by the trainer. Indications between 0.8 m and 1.6 m and

1.6 m and 2.4 m from the mine were considered doubtful, and were therefore noted but not rewarded. All indications beyond 2.4m were treated as false indications. The reason for adopting the 0.8m radius as a cut-off distance for hits was made for practical reasons. If a rat made an indication in a lane next to the lane where a mine was buried this was still considered as a hit but in a lane further away it was considered as doubtful or a false positive. For all indications in adjacent lanes (38), the average distance from the exact position of the mine to the indication was 0.78 cm. We therefore accepted a radius of 0.8 m as the cut-off point.

When looking at the example in Fig. 2, it is clear that interpretation of field data is not straightforward. The upper mine is indicated nine times with four indications within the 0.8 m circle (for which the rat was rewarded). There were also three indications in the outer circles and two outside the 2.4 m circle, which were noted in the field as false positives. When reviewing the field notes afterwards, we considered the most appropriate explanation to be that all nine indications were caused by the presence of that one mine because of the directional relationship between the mine and the indications. Further supporting the conclusion was that there had been heavy rains in the days before and run-off of water was in the direction towards the more distant indications. When analysing the data, the four indications within the 0.8 m circle were taken together as one hit while all indications outside this inner circle were treated as individual false positives. In some analyses indicated below, we also used the 1.6 m and the 2.4 m radius for acceptance of all indications as a hit. In the example given in Fig. 2, this would mean that for a 2.4m radius there would be seven indications inside (giving one hit) and two false positives outside.

In the case of the lower mine in Fig. 2, the two indications in the outer circle would have been counted as two false positives for either the 0.8 m or 1.6 m evaluation circles, but as one hit for the 2.4 m circle.

This approach becomes difficult when two or more mines are situated close together and their evaluation circles overlap. However, as most rats indicate several times in the vicinity of a mine giving a clear grouping of indications, it is possible in most cases to make a decision on the probable positions of the two mines. From an operational perspective, interpretation of such data can be difficult and one may take factors such as topography of the area into account when making a decision.

The performance of a rat inspecting a box was expressed as the number of hits divided by the number of mines present in that box, hereafter called the **success score**.

## Results

Rats working in the field are subject to many factors that influence their behaviour. First, there are factors that influence the concentration of explosives in the air and topsoil (temperature, humidity and structure of the soil, presence and density of vegetation, density of mines). Second, local conditions may profoundly alter the behaviour of the rats while searching (humidity, sunshine and temperature, density and height of vegetation). Third, some variation might be expected depending on the interpretation of the behaviour of the rats as observed by the trainer. Fourth, there are differences in the performance between rats.

### Overall performance

The nine rats evaluated 81 boxes (9/rat). It rained during three nights (28-29/5, 30/4-1/5 and 5-6/5) giving wet conditions on the following days. A rat stopped evaluating a box before it was completely finished on 11 occasions, and these results were not incorporated into the analysis (Table 1). On dry days, rats stopped working because it became too hot, whereas during wet days animals stopped because vegetation and soil were too wet.

When there was rain the previous night, success score was lower than when there was no rain (Table 1, Fig. 3). Success score improved when indications were accepted from a larger area around the mine, especially when conditions were wet.

**Table 1**  
Summary of the performance of *Cricetomys* rats under different weather conditions and at various distances from the location of the mine

|                            | Dry days | Wet days |
|----------------------------|----------|----------|
| Number of boxes tested     | 53       | 28       |
| Number not completed       | 6        | 5        |
| Number of mines            | 125      | 65       |
| Hits (within 0.8 m radius) | 100      | 41       |
| % success score <0.8 m     | 80.0     | 63.1     |
| Hits (within 1.6 m radius) | 103      | 50       |
| % success score <1.6 m     | 83.7     | 74.6     |
| Hits (within 2.4 m radius) | 110      | 52       |
| % success score <2.4 m     | 88.7     | 80.0     |

In order to determine whether the rats were giving most indications close to mines, we plotted the density of indications made by all rats in the area between the circles with a 0.8 m and 1.6 m radius (6.02 m<sup>2</sup>), the area between the circles with a 1.6m and 2.4 m radius (10.05 m<sup>2</sup>), and all indications outside the 2.4 m radius (81.91 m<sup>2</sup>). These values were expressed as per square metre for the three given areas. If indications were randomly distributed throughout the box rather than concentrated close to mines, then one would expect the graph to be a flat line. However, a sharp drop in density of indications by the rats in relation to distance from the mine can be seen in Fig. 3, indicating that most indications were close to mines.

The progressive drop in indications at increasing distances from the mine implies that contamination of the soil around a mine is not limited to a small area — explaining why the rats gave some indications at a distance from the mine. The pattern of spread of odour away from the mine will depend very much on local topographical characteristics, soil texture and local water flow. Although few indications were given outside the 2.4 m radius, it is clear that decisions about the relationship between mines and indications requires consideration of a larger area than just the inner 0.8m circle. The contamination at larger distances is more pronounced when it is wet. In this data set, the number of indications beyond a distance of 2.4 m was very low and there was no difference between wet and dry days. On average a rat had 1.6 such false indications per box. These indications will be considered as false positives in all subsequent analyses.

Figure 3  
Relation between the number of positive indications and distance from the mine

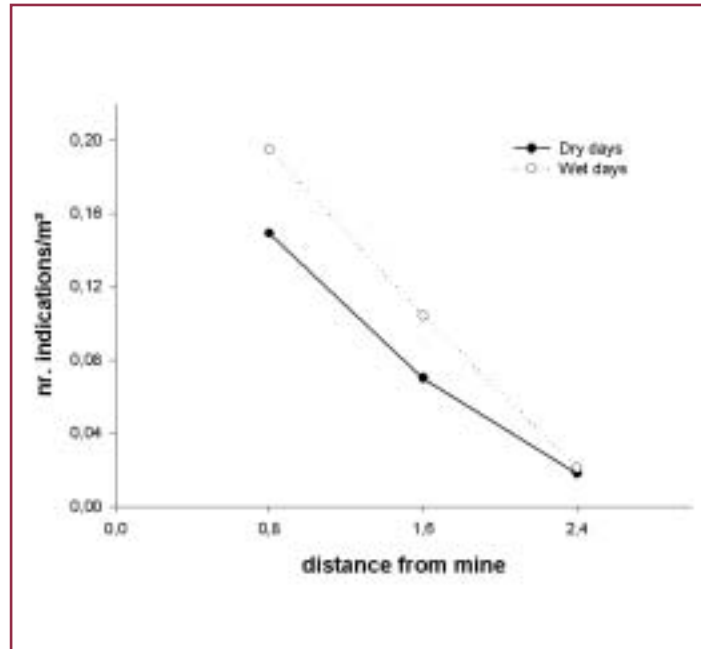

#### Individual variation

There was considerable variation in performance between the free running rats. This variation can be used to select those rats most suited to be free running rats, and identify rats needing re-training or rejection using a defined criterion.

As performance of the rats in the field is potentially influenced by several known factors (weather, time of the day, number of mines present in a box) and probably also still unknown factors, we have to take these into account when assessing the quality of the rats. Table 2 summarises some aspects of the performance of the nine rats in the field when they searched a lane one or two times.

Success score varied considerably between individuals, ranging from as low as 67 per cent (Dina) up to 100 per cent (Julie) when conditions were dry using an evaluation radius of 2.4 m (two-lane evaluation). Also the number of boxes scored without errors, meaning that all mines present in the box were found and no false positive indications were given, varied in the same way from 0 per cent (Johan) up to 100 per cent (Bean and Julie).

The source of the individual variation was explored using a one-way breakdown analysis of variance of the grouping variables age and sex on the measured dependent variables of: i) success score, ii) search time, and iii) number of false positive indications. This analysis allows evaluation of the differences between dependent variables (success score, search time, false positives) in relation to defined independent (grouping) variables (age and sex). If the variance within each dependent variable is larger than the variance between grouping variables, then one can conclude that there is no effect of age or sex on the measured variables. On the other hand, if the between-group

**Table 2**  
Summary of performance of the individual rats as evaluated at 0.8 and 2.4m from the mine for wet and dry testing days (m-index = mean number of mines present in the boxes that a particular rat investigated; time = mean time in minutes the rats started working on the field, 7.00 a.m. is taken as zero point)

| Rat                               | Boxes correct                                      |        |       |       | Success score                                    |       |         |         |
|-----------------------------------|--|--------|-------|-------|--|-------|---------|---------|
|                                   | Wet  |        | Dry   |       | Wet  |       | Dry     |         |
|                                   | 0.8 m  | 2.4 m  | 0.8 m | 2.4 m | 0.8 m  | 2.4 m | 0.8 m   | 2.4 m   |
| <b>Rataplan</b>                   | <i>(Box-wet n = 3, m-index = 2.3, time = 160;)</i> |        |       |       | <i>Box-dry n = 5, m-index = 2.8, time = 142)</i> |       |         |         |
| 2-lanes                           | 0%   | 67%    | 40%   | 60%   | 29%  | 71%   | 79%     | 86%     |
| 1-lane                            | 0%   | 33%    | 40%   | 60%   | 29%  | 43%   | 64%     | 79%     |
| <b>Bean</b>                       | <i>(Box-wet n = 3, m-index = 2.7, time = 53;)</i>  |        |       |       | <i>Box-dry n = 5, m-index = 2.2, time = 99)</i>  |       |         |         |
| 2-lanes                           | 0%   | 67%    | 100%  | 100%  | 50%  | 88%   | 100%    | 100%    |
| 1-lane                            | 0%   | 33%    | 80%   | 80%   | 38%  | 75%   | 91%     | 91%     |
| <b>Apoc</b>                       | <i>(Box-wet n = 3, m-index = 3.3, time = 113;)</i> |        |       |       | <i>Box-dry n = 7, m-index = 2.3, time = 100)</i> |       |         |         |
| 2-lanes                           | 0%   | 33%    | 86%   | 86%   | 60%  | 80%   | 94%     | 94%     |
| 1-lane                            | 0%   | 33%    | 86%   | 86%   | 50%  | 70%   | 88%     | 88%     |
| <b>Bianca</b>                     | <i>(Box-wet n = 2, m-index = 3.5, time = 60;)</i>  |        |       |       | <i>Box-dry n = 5, m-index = 2.6, time = 108)</i> |       |         |         |
| 2-lanes                           | 0%   | 0%     | 20%   | 40%   | 43%  | 57%   | 62%     | 69%     |
| 1-lane                            | 0%   | 0%     | 20%   | 40%   | 29%  | 57%   | 54%     | 69%     |
| <b>Dina</b>                       | <i>(Box-wet n = 1, m-index = 3, time = 55;)</i>    |        |       |       | <i>Box-dry n = 5, m-index = 3.0, time = 76)</i>  |       |         |         |
| 2-lanes                           | (100%)   | (100%) | 20%   | 40%   | 100%   | 100%  | 60%     | 67%     |
| 1-lane                            | (0%)   | (0%)   | 20%   | 40%   | 67%  | 67%   | 47%     | 67%     |
| <b>Switch</b>                     | <i>(Box-wet n = 3, m-index = 2.3, time = 100;)</i> |        |       |       | <i>Box-dry n = 5, m-index = 2.2, time = 56)</i>  |       |         |         |
| 2-lanes                           | 67%  | 67%    | 60%   | 80%   | 86%  | 86%   | 82%     | 91%     |
| 1-lane                            | 67%  | 67%    | 60%   | 80%   | 86%  | 86%   | 82%     | 91%     |
| <b>Johan</b>                      | <i>(Box-wet n = 3, m-index = 2.7, time = 110;)</i> |        |       |       | <i>Box-dry n = 4, m-index = 3.5, time = 88)</i>  |       |         |         |
| 2-lanes                           | 33%  | 33%    | 0%    | 0%    | 75%  | 75%   | 71%     | 71%     |
| 1-lane                            | 33%  | 33%    | 0%    | 0%    | 75%  | 75%   | 64%     | 71%     |
| <b>Mathias</b>                    | <i>(Box-wet n = 2, m-index = 3.5, time = 100;)</i> |        |       |       | <i>Box-dry n = 6, m-index = 3.0, time = 79)</i>  |       |         |         |
| 2-lanes                           | 0%   | 0%     | 50%   | 50%   | 57%  | 71%   | 78%     | 83%     |
| 1-lanes                           | 0%   | 0%     | 33%   | 33%   | 57%  | 57%   | 67%     | 78%     |
| <b>Julie</b>                      | <i>(Box-wet n = 3, m-index = 2.7, time = 78;)</i>  |        |       |       | <i>Box-dry n = 5, m-index = 2.3, time = 76)</i>  |       |         |         |
| 2-lanes                           | 67%  | 100%   | 100%  | 100%  | 88%  | 100%  | 100%    | 100%    |
| 1-lanes                           | 33%  | 67%    | 60%   | 100%  | 75%  | 88%   | 100%    | 100%    |
| <b>Results of all rats pooled</b> |  |        |       |       |  |       |         |         |
| 2-lanes                           | 6/23   | 12/23  | 26/47 | 30/47 | 41/65  | 52/65 | 100/125 | 105/125 |
|                                   | 26%  | 52%    | 55%   | 64%   | 63%  | 80%   | 80%     | 84%     |
| 1-lanes                           | 4/23   | 7/23   | 22/47 | 27/47 | 36/65  | 45/64 | 90/125  | 101/125 |
|                                   | 17%  | 30%    | 47%   | 57%   | 55%  | 69%   | 72%     | 81%     |

variance is larger than the within-group variance, then it can be concluded that there is a strong effect of age or sex on the dependent variables. There was no effect of sex on the three listed parameters. For age, there was a non-significant trend for success score to become better as animals aged, which is probably because older rats have been trained for a longer time. There was no effect of age on search time or false positives.

### Time animals are working

Soil humidity had an important effect on performance and this relationship could also be true for temperature. *Cricetomys* rats are very temperature sensitive and all

testing was done between 7.30 a.m. and 10.30 a.m., after which it became generally too hot for rats to function properly. At 7.30 a.m. temperatures were around 20°C and rose to between 27 and 32°C towards 10.30 a.m., depending on the amount of cloud.

In Fig. 4 we plot the relation between the time through the morning and success score, the number of all indications given by the rats within the 0.8-2.4 m sector (calculated in the same way as for Figure 3), and the number of indications given outside the 0.8-2.4 m sector. Relationships were analysed using regression analysis, which investigates the pattern of change for a factor across a series of measurements (in this case through time).

When conditions are dry, success score decreases significantly through the morning ( $r=0.9791$ ;  $p=0.0036$ ). There is no such clear relationship when rain falls during the night before testing so that the ground is wet during testing. On dry days there is always some dew in the early morning, which disappears quickly making evaporation less and the concentration of explosives above ground level decreases.

Indications in the 0.8-2.4 m zone support the result above. During dry days there is a sharp drop in the number of indications early in the morning, after which indications stabilise. During wet days the decrease is more gradual and the number of indications is higher compared with dry days.

The patterns for the number of indications outside the 2.4 m circle were different for wet and dry days, and also differed from the patterns in the other two graphs, suggesting no relationship with environmental conditions.

#### Effect of evaluation radius, times a lane was evaluated, and number of mines on the success score

Data from the boxes allow us to analyse how success score varies with evaluation radius, and the number of times a lane is searched (one or two). A summary of the analysis is given in Table 3.

| Condition              | Wet  |       | Dry  |        |
|------------------------|------|-------|------|--------|
|                        | 0.8m | 1.6m  | 0.8m | 1.6m   |
| <b>One mine/box</b>    |      | (n=3) |      | (n=8)  |
| % success score        |      |       |      |        |
| - lane twice           | 33   | 33    | 100  | 100    |
| - lane once            | 33   | 33    | 100  | 100    |
| <b>Two mines/box</b>   |      | (n=5) |      | (n=14) |
| % success score        |      |       |      |        |
| - lane twice           | 60   | 90    | 90   | 89     |
| - lane once            | 60   | 90    | 90   | 86     |
| <b>Three mines/box</b> |      | (n=9) |      | (n=11) |
| % success score        |      |       |      |        |
| - lane twice           | 67   | 74    | 78   | 79     |
| - lane once            | 56   | 59    | 63   | 76     |
| <b>Four mines/box</b>  |      | (n=6) |      | (n=14) |
| % success score        |      |       |      |        |
| - lane twice           | 63   | 79    | 79   | 79     |
| - lane once            | 58   | 71    | 71   | 77     |



Figure 4  
 Relation between the time through the morning and success score (number of indications within the 0.8-2.4 m circles, and number of indications outside the 2.04 m circle)

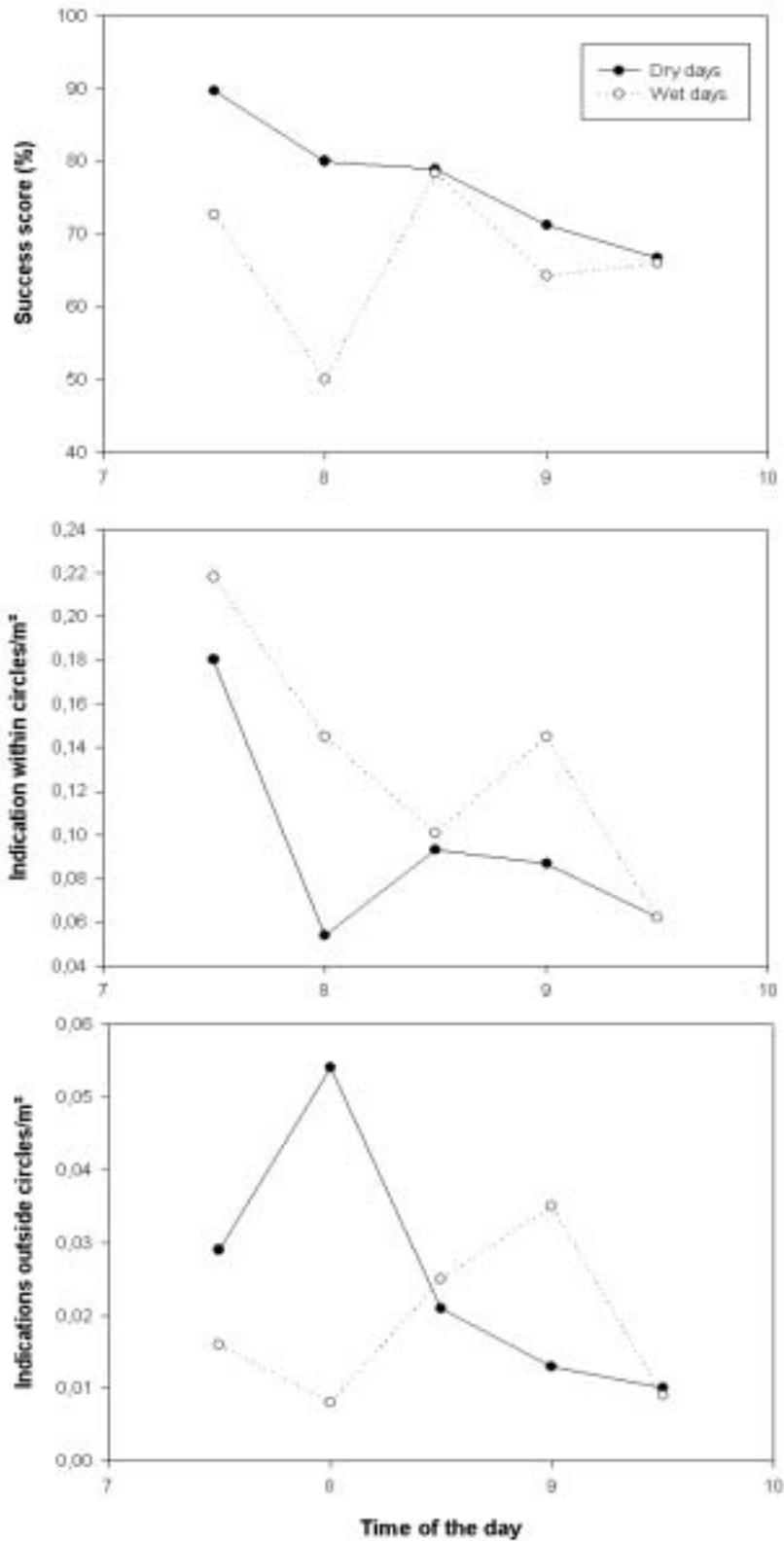

To investigate which of the three factors (number of mines, number of times the lane was searched, and evaluation radius) influenced the success score we used a multivariate linear Anova after log-transforming the raw data. The analysis identifies variables with significant amounts of variation. Log-transformation is used to satisfy background assumptions of the analysis, and does not change the patterns in the data. Data for dry and wet days were analysed separately. The results from this analysis are straightforward as can be seen in Table 4.

|                   | Factor            | df      | F-value  | p-value      |
|-------------------|-------------------|---------|----------|--------------|
| Wet days          | 1-mines           | 3       | 17.96760 | <b>0.000</b> |
|                   | 2-lanes           | 1       | 0.29921  | 0.585        |
|                   | 3-radius          | 2       | 20.09292 | <b>0.000</b> |
|                   | Interaction 1x2   | 3       | 0.10495  | 0.957        |
|                   | Interaction 1x3   | 6       | 7.46691  | <b>0.000</b> |
|                   | Interaction 2x3   | 2       | 0.00631  | 0.994        |
|                   | Interaction 1x2x3 | 6       | 0.01665  | 1.000        |
|                   | Dry days          | 1-mines | 3        | 4.95503      |
| 2-lanes           |                   | 1       | 1.69083  | 0.195        |
| 3-radius          |                   | 2       | 3.39827  | <b>0.035</b> |
| Interaction 1x2   |                   | 3       | 0.71733  | 0.542        |
| Interaction 1x3   |                   | 6       | 1.92891  | 0.077        |
| Interaction 2x3   |                   | 2       | 0.83243  | 0.436        |
| Interaction 1x2x3 |                   | 6       | 0.35312  | 0.908        |

For both wet and dry days the number of mines present in a box and the evaluation radius used were both very significant, with more mines/box resulting in a lower success score, and a larger evaluation radius resulting in a higher success score (see Table 1). The significant interaction for mines x radius (significant for wet days and nearly significant for dry days), indicates that the two factors have opposite effects: the negative effect on the success rate of having more mines in a box will be largely compensated by the positive effect of using a larger evaluation radius. The fact that this is more obvious for wet days than for dry days is understandable as we have seen that probably contamination/evaporation of the surroundings of a mine is more widespread during wet days and therefore this interaction should be stronger.

Evaluating a lane once or twice by the same rat had no significant effect on the success score. Although there is a relatively large difference when the evaluation area is small (<0.8 m), the difference disappears nearly completely when a larger evaluation area is used.

For practical reasons (locating the mine) it is important to keep the evaluation radius as small as possible. In this study we used three circles (radius 0.8 m, 1.6 m and 2.4 m) around the centre of the site where the mine was buried. The largest circle (2.4 m) gave the best results, but using that radius means that a large area around the indication is treated as suspect (18 m<sup>2</sup>). Therefore one should try to find the best compromise between radius and increase in success score. In the case of the dry field data the success score increased as described below (only results from boxes with more than one mine were used because those with only one mine had a success rate of 100 per cent).

The biggest increase in success score is attained when the radius is increased to 1.6 m and when the lane is searched once only. Increasing the radius further has very little effect on the success score. With a radius of 1.6 m an area of 8 m<sup>2</sup> has to be cleared instead of 18 m<sup>2</sup> in the case of a 2.4m radius (Table 5).

|                    | % increase in SS;<br>0.8 to 1.6 m | % increase in SS;<br>1.6 to 2.4 m |
|--------------------|-----------------------------------|-----------------------------------|
| 2 lanes evaluation | 5.0                               | 1.9                               |
| 1 lane evaluation  | 13.6                              | 2.0                               |

These results indicate that when using a larger evaluation area around the mine there is almost no difference between the success score of a rat searching each lane once or twice. Therefore the time for evaluating a box can be reduced by a factor of two when all lanes are evaluated only once, if the larger clearance areas are used. It can also be expected that when using this method the success score could increase, as concentration of the rats will remain higher if they work for a shorter time period, especially at higher temperatures. A second possibility for reducing total working time is to increase the width of lanes from 0.5-1 m. This possibility has to be tested in future field experiments.

The fact that there is a strong negative relation between success score and the number of mines present in a box will only pose a problem in very dense minefields. As with dogs, rats are likely to be removed from such situations and other demining techniques used.

#### Selection criteria for free running rats

The number of mines per box and time during the morning of working had an important impact on the success score of individual rats. When selecting animals for maximum performance these factors should therefore be taken into account. In order to find out which of the two factors (number of mines per box or working time) had the biggest impact on success score, we used a multiple regression analysis. The dependent variable was success score, and mean number of mines per box and time of the day when the animals were working were the independent variables. We used the data of the one lane evaluation.

The most important factor was the number of mines per box ( $r=0.7887$ ,  $df=2,6$ ;  $F=4.937$ ;  $p=0.0540$ ; partial correlation for success score versus mines per box  $t(6)=-3.0044$  with  $p=0.0239$  and partial correlation for time versus success score  $t(6)=-0.6129$  with  $p=0.5624$ ). Residual analysis indicated two animals that did not fit the general equation, namely Bianca and Dina. Excluding them from the data-set produced a nearly perfect fit ( $r=0.90058$ ,  $df=2,4$ ;  $F=8.585$ ;  $p=0.0357$ ; partial correlation success score versus mines per box  $t(4)=-4.11204$  with  $p=0.0147$  and partial correlation of time versus success score  $t(4)=-0.27318$  with  $p=0.7982$ ).

From this analysis one can conclude that if the number of mines in the boxes were the same, then seven of the nine rats would have a comparable success score. The exceptions were Bianca and Dina, whose success score was considerably lower and

they should therefore not be used as free running rats with the present level of performance (Table 6). At this time, it is too early to define an acceptance criterion for accrediting a free-running rat for operational purposes, as all rats are still in a training stage. The results are plotted in Fig. 5.

Figure 5  
Relation between mean success score of an individual rat and the mean number of mines present in the box, Bianca and Dina are not included in the regression

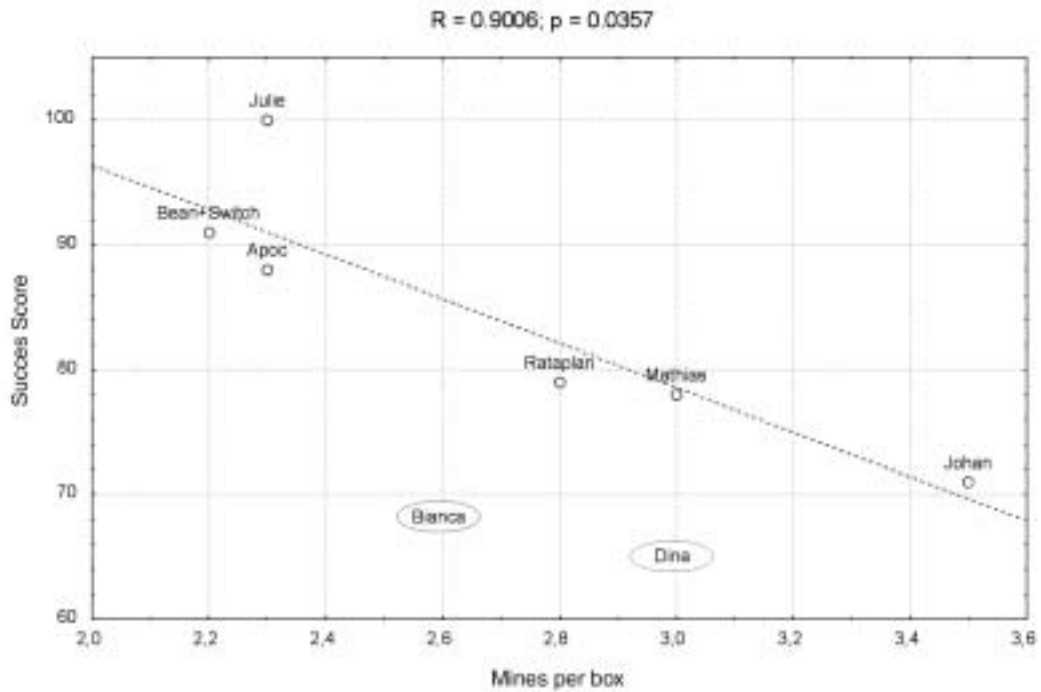

Table 6  
The effects on overall performance of omitting both Bianca and Dina from the success scores.

| Rat   | Boxes correct |              |              |              | Success score |              |                |                |
|---|---------------|--------------|--------------|--------------|---------------|--------------|----------------|----------------|
|   | Wet           |              | Dry          |              | Wet           |              | Dry            |                |
|   | 0.8 m         | 2.4 m        | 0.8 m        | 2.4 m        | 0.8m          | 2.4 m        | 0.8 m          | 2.4 m          |
| <b>Results of all rats pooled</b>                         |               |              |              |              |               |              |                |                |
| 2-lanes   | 6/23<br>26%   | 12/23<br>52% | 26/47<br>55% | 30/47<br>64% | 41/65<br>63%  | 52/65<br>80% | 100/125<br>80% | 105/125<br>84% |
| 1-lanes   | 4/23<br>17%   | 7/23<br>30%  | 22/47<br>47% | 27/47<br>57% | 36/65<br>55%  | 45/64<br>9%  | 90/125<br>72%  | 101/125<br>81% |
| <b>Results of all rats pooled without Bianca and Dina</b> |               |              |              |              |               |              |                |                |
| 2-lanes   | 5/20<br>25%   | 11/20<br>55% | 24/37<br>65% | 27/37<br>73% | 35/55<br>64%  | 45/55<br>82% | 83/97<br>86%   | 87/97<br>90%   |
| 1-lanes   | 4/20<br>20%   | 7/20<br>35%  | 20/37<br>54% | 24/37<br>65% | 32/55<br>58%  | 39/55<br>71% | 80/97<br>82%   | 87/97<br>90%   |

### How many rats have to inspect a given box to get effective detection?

Sixteen boxes were searched by four or more rats and each lane of the box was evaluated twice by each rat. To calculate how many rats should inspect a box to be sure that all mines were identified, we analysed all possible combinations of rats that evaluated boxes with 1, 2, 3 and 4 mines for both the one- and two-lane evaluation. The combination with the highest number of rats needed to get 100 per cent detection was taken as the minimum number of rats required. Results presented here are for the 2.4 m evaluation radius and figures give the minimum number of rats needed to get 100 per cent detection (Table 7).

| Mines/box | Nr. boxes | One-lane evaluation | Two-lane evaluation |
|-----------|-----------|---------------------|---------------------|
| 1         | 4         | 2                   | 1                   |
| 2         | 4         | 3                   | 2                   |
| 3         | 4         | 4                   | 3                   |
| 4         | 4         | 4                   | 4                   |

As was expected from the previous results, the more mines present in a box the more rats are needed to evaluate a box to get 100 per cent detection. If we expect that never more than two mines will be present on a 100 m<sup>2</sup> area, then three rats should be enough to evaluate such an area. If high density bands of mines are encountered, the rats should be withdrawn and some other search/clearance technique used.

## Conclusions

The approach used in this paper was to attempt to define the capabilities of *Cricetomys* rats in an experimental way by using the rats themselves to search for mines. Although testing of the free running rat is still in an experimental phase, this method might have great potential for the location of mines in suspected areas. In these analyses, we have identified a range of factors that affect the quality of performance of rats. Conversion of these factors to rules will further improve the reliability of rats in a mine detection role. In order of importance these are:

- Never let them work during or just after rain or when the soil is too wet;
- Start working early in the morning when temperatures are likely to rise fast or when it is an open blue sky.

From the results of this study it is clear that several adaptations could be made to further increase the efficiency of rats in a mine detection role. Evaluating a lane once rather than twice would improve search rate. Increasing the distance between lanes will further increase productivity, and is potentially justified as contamination from a mine is probably more widespread than 0.5 m. More information is needed on the distribution of explosive odours in the soil and factors that influence this distribution, so that optimal working conditions can be determined.

The use of rats as bio-sensors can have a direct application to the process of area reduction.

---

## References

- Biederman, G.B. (1990)  
*The detection of explosives by an automated small-animal system*, National Research Council, National Aeronautical Establishment, Ottawa.
- Nolan R.V., S. Weinstein and C. Weinstein (1978)  
*Neurophysiological, operant, and classical conditioning methods in rats in the detection of explosives*, presented at 3rd Annual Meeting of Role of Behavioral Science in Physical Security.
- Weinstein C., S. Weinstein and R. Drozdenko (1992)  
“The challenge of biodetection for screening persons carrying explosives”, in S.M. Khan (ed.) *Proceedings, First International Symposium on Explosive Detection Technology*, pp. 759-769.

---

## Acknowledgements

We are very grateful to the authorities of the Sokoine University of Agriculture, Morogoro, for providing us all the facilities necessary to carry out this work. The Belgian Ministry of Development Aid (DGIS) financed the research project. We sincerely thank Dr. Ian McLean for his valuable comments and corrections on the first draft of this chapter. Especially we are very obliged to all people working at APOPO for their continuous effort and enthusiasm. Finally we have to thank the logistic support of the Tanzania Peoples Defence Forces (TPDF).

---





## Chapter 5

### Odour detection: the theory and the practice

#### Part 1

# How do dogs detect landmines?

## A summary of research results

*Ann Göth, Ian G. McLean and James Trevelyan*

### Summary

- The odour discrimination skills of dogs considerably exceed the abilities of laboratory machines used in attempts to investigate those skills, limiting the ability of researchers to study the skills and limitations of dogs for detection of mines.
- Dogs clearly learn to detect mines using the odour of explosives and other chemicals leaking from mines.
- The availability of odour to dogs varies in complex ways with the environment in which the mine occurs. Influences include soil types, soil moisture, activity of micro-organisms, and climatic variables.
- Dogs are able to discriminate extremely faint signals (target odours) against a very noisy background (masking odours).
- Dogs are able to learn to discriminate up to ten odours without difficulty — the limits to the number of odours that can be learned have not been explored.
- Learned discrimination skills are retained for up to 120 days by dogs that are not operational. The longevity of detection skills of operational dogs may be influenced by operational experiences, and this result should not be used to justify a reduction in maintenance training for discrimination skills.
- Leakage rates vary amongst different mines. It is likely that the availability of odours from at least some mines drops below the detection threshold of dogs at least some of the time. This problem requires further research.
- Generalisation from learned discrimination odours to related but somewhat different odours (e.g. TNT from another production source) was not reliable.
- Dogs are able to use many of the contamination, degradation, and other products which occur naturally in TNT, and the actual odours used by any particular dog to detect a mine cannot be known or predicted from the training programme.

- Training programmes for dogs should include experience with bouquets from mines in a deployment theatre, even if the main training programme uses TNT exclusively. Such experience should be updated regularly using a maintenance training programme.



## Introduction

The use of dogs for demining purposes began in the 1939-45 war, but dogs have only become established as a significant contributor to the global humanitarian demining effort in the last few years. Today, more than 750 dogs are used in humanitarian demining programmes in some 23 countries.

The main advantages of dogs are that they can verify suspected land faster than manual (i.e. human) demining teams, they offer a relatively low-tech and flexible option in difficult post-war situations, they can find mines with little or no metal content, and they can work in situations where large amounts of metal debris prevent the use of standard metal detectors.

Despite the increased deployment of mine detection dogs in the field, little is known about the processes by which they detect mines. A dog's powerful sense of smell, known as the olfactory ability, is many times better than that of a human. The olfactory centre in the brain of a human is about 40 times smaller than for an average dog. When an odour, consisting of molecules, lands on membrane tissue within the nose, information about it is gathered, processed, and sent to the brain. The type and number of molecules actually required by dogs to identify landmines are not known, and this

lack of knowledge negatively effects the training and deployment of mine detection dogs (MDDs).

Today, there is still considerable reliance on tradition and folklore in the vocation of canine detection, and most agencies have different approaches to the training of MDDs. It has to be kept in mind that search dogs trained for roles other than hunting are not seeking odours of natural (or intrinsic) relevance. Rather, the handler/trainer has linked the natural tendency of the dog to search for intrinsic rewards to unnatural target odours, using operant conditioning procedures. Operant conditioning produces an animal that will search for any cues that produce reinforcement (Lieberman, 2000). The challenge for trainers and handlers is to know which cues the operant conditioning should best be based on. With respect to landmines, it is self evident that these cues should be odours from the mine that are most easily detected by the dog and are consistently present in the air or on the soil surface. To identify those cues, researchers address issues arising from the following broad questions:

1. Which substances found in landmines can dogs detect, in what concentrations do they detect them, and how do environmental factors affect their ability to detect these substances?
2. Which of the many chemical substances contained in a mine are actually available in the air above a mine or on the soil surface?

## Aim

The aim of this report is to provide a non-technical summary of existing results that address the above two questions and to comment on application of these results to the training and deployment of mine detection dogs. Some preliminary recommendations are made in the conclusions, but it is too early for firm recommendations to be made. The information used comes mostly from published and unpublished research results at Auburn University ([www.vetmed.auburn.edu/ibds](http://www.vetmed.auburn.edu/ibds)), the U.S. Army Corps of Engineers ([www.usace.army.mil](http://www.usace.army.mil)) and Sandia National Laboratories ([www.sandia.gov](http://www.sandia.gov)). A detailed technical review is in Chapter 5, Part 2.

## Canine olfactory capabilities and characteristics

This chapter summarises results of research that concentrated on identification of substances from landmines that are detectable to dogs. A major centre for such research is at the Institute for Biological Detection Systems (IBDS) at Auburn University in Alabama/U.S.

TNT (Trinitrotoluene) is one of the most common explosives found in landmines — it occurs in approximately 80 per cent of all mines. However, explosives that are based on TNT contain by-products other than pure TNT, primarily impurities and degradation products such as DNB (Dinitrobenzene) and DNT (Dinitrotoluene). When a trained dog detects the explosive TNT, handlers do not know which of these (or other) compound(s) the dog is responding to. In other words, the handler knows that the dog detects what it is trained to detect, but it is unknown which specific vapour (or combination of vapours) the dog uses to recognise TNT. Dogs are thus deployed in very important detection roles without a clear understanding of which stimuli control their alert responses.

To explore the sensitivity of dogs to different chemical components of TNT, the IBDS made specific observations on dogs trained to identify odour from military grade TNT in experimental chambers (Fig. 1).<sup>1</sup> One compound, 2,4-DNT, gave the most consistent response across all dogs studied, followed by 1,3-DNB (Cicoria, 1999). Following this experiment, the sensitivity of dogs to decreasing concentrations of 2,4-DNT was tested, using the same experimental set-up and five dogs. The result was that the sensitivity of the dogs for odour with 2,4-DNT declined rapidly in a region between about 200 parts per-trillion (ppt) and 1000 ppt<sup>2</sup> (Johnston, 1998). These sensitivity estimates approach the limits of current technology for independent measurement of such minute chemical samples (about 1 ppt, J. Phelan, pers. comm.). Dogs are now known to be able to do much better (J. Phelan, unpubl.).

To relate their results to a more natural situation, researchers at the IBDS conducted an additional test, again in the same test chamber. Those dogs that had been trained on TNT were now also tested on various other constituents of landmines, including plastic case uncontaminated with TNT.<sup>3</sup> Again, DNT generated the most consistent response from the dogs. The plastic case was not used as a detection cue by the dogs in this experimental preparation, as its vapour evoked little response (P. Waggoner, pers. comm.).

In a natural situation, the dog must distinguish the odour of TNT or DNT from many other odours extraneous to the target odour. In so-called “masking experiments” at the IBDS, again in the same experimental chambers, target odours were presented to the dogs in combination with numerous other substances. The results indicated that dogs detect very low relative concentrations of target odour in the presence of strong masking odours (Waggoner *et al.*, 1998). At a target odour concentration of about 1 ppb, the concentration of the masking odour needed to be at about 20 ppm before detection performance began to be affected (a ratio difference of more than 3 orders of magnitude, or one in 1,000). Even then, the effect was a decline in performance, not a complete loss of detection skills. As with experiments on detection thresholds by Phelan and Barnett (unpubl., pers. comm.), considerable variation was found among individual dogs.

The researchers investigated time delay (or “forgetting”) in their ability to retain a conditioned discrimination skill without refresher training. There was very little loss of learned discrimination skills after delay periods ranging from 14 to 120 days (Johnston *et al.*, 2000).<sup>4</sup> This result is promising, but the dogs were not operational, so were not receiving regular (i.e. daily) reminder training (whether intended or otherwise) of learned discriminations. It is therefore not appropriate to assume that

---

1. Methodology: Five random source dogs from animal shelters, medium to large in size, were trained to detect TNT. They worked in an experimental chamber (Skinner box) in which they sampled from an air stream. They then indicated whether they smelled the odour from TNT or clear air by pressing different levers. This performance was trained and maintained by delivery of food for correct responses and a brief blackout of chamber illumination for incorrect responses. To assess which constituents of the vapour from TNT contributed to detection by dogs, individual constituents found in the vapour of TNT were presented to the dogs.

2. 100 ppt approximately equals 1 nanogram per litre, another commonly used unit.

3. The dogs were tested on: DNB, mixtures of DNT and DNB, vapour generated from the landmine plastic case, a landmine case with three different amounts of TNT, a block of TNT from a PMA-1A mine without the plastic case, and toluene (as control substance).

4. In these controlled field experiments, dogs were asked to walk about a circle and sample from fixed sampling positions. The data therefore describe the relationship between training intervals and remembering odour discriminations. The data do not, however, address the frequency of training required to maintain proficiency in operational searching.

operational dogs will similarly retain discrimination skills for long periods in the absence of reminder training.

Figure 1

A dog in the experimental chamber first hears a specific sound (left), sticks her nose into a glass cylinder, in which various odours are presented (middle), and then presses one of the two levers with her snout to indicate whether she had smelled clean air or the target odour (right).



Photo: Institute for Biological Detection Systems (IBDS), Auburn University.

Also of interest was that dogs could easily be trained to detect up to 10 different odours with no indication of a decline in odour discrimination performance when this number was learned. Ten odours was the maximum attempted in the experiment and it seems likely that some or even many more odours could be trained (Williams *et al.*, 1997).

In another experiment at the IBDS, again in the same experimental chamber, dogs were trained on American TNT after which their ability to detect TNT from other countries was tested.<sup>5</sup> All five dogs detected Chinese TNT, four dogs detected re-crystallized American TNT, but only two detected a PMA-1A landmine (which contained mainly TNT; Cicoria, 1999). Currently, the same research institute is repeating this experiment in their controlled field set-up, where dogs sniff TNT from different countries or manufacturers in a circle with fixed sampling positions. The first results indicate that dogs do not readily detect variants of TNT other than that on which they have received explicit training (Paul Waggoner, pers. comm.). Of course, this result may be an artefact of the dogs being trained to detect a specific variant of TNT in a rather sterile context compared to that in which operational dogs are typically trained.

IBDS researchers also assessed how long detection dogs can work under varied conditions. Within the context of the study, they worked effectively for at least 90-120 minutes of continuous searching, which was the maximum they were trained to work for. However, environmental temperature affected dog performance — high temperatures can decrease a dog's detection capability, even if the animal is not tired and was trained to search for extended periods in areas with low target availability (Garner *et al.*, 2000).<sup>6</sup> It should be kept in mind that this study was carried out in the

5. Methodology: five dogs were trained on US. Mil. Spec. TNT and then tested on the following other three types of TNT (apart from a control): (1) re-crystallized Mi. Spec. TNT from the U.S.; (2) TNT produced in China and (3) on a PMA-1A landmine from the former Yugoslavia, which contains mainly TNT.

6. In this study, five trained detection dogs were deployed in a variety of real-world scenarios, indoor and outdoor, and across a 12-month period. Their performance and physiological factors, such as heart rate and body temperature, were then compared with environmental factors, such as outdoor temperature and humidity. High outdoor temperature related to decreased detection performance in two of the dogs. The total search duration weakly related to the number of false alarms, but was not related to the probability of detection.



high humidity of Auburn/Alabama, where the climate is not representative of the dryer heat typical of many countries in which mine detection dogs are deployed. It appeared that humidity had little effect on dog performance, but there were too few days with a combination of high humidity and high heat to adequately assess the effects of these two environmental factors separately (P. Waggoner, pers. comm.).

## What substances from landmines are available to the dogs?

The previous section summarised results on the substances from landmines that dogs seem to use as identification cues, and under which conditions they work best. But such knowledge has little value unless it is known what substances from a mine (henceforth simply called “mine substances”) are available to the dogs in a real minefield. Investigating the availability of chemicals offers a good hint on what mine substances dogs may use as detection cues.

The next two sections address the following issue: Do the chemical characteristics of various mine substances (vapour pressure, diffusion, etc.) predict how likely these are to be present in the air or on the soil surface? Or in other words: Can we predict the likelihood of mine substances finding their way to the dog’s nose from their chemical “behaviour”? Linked to this problem is the effect of environmental factors, such as rainfall, on the “behaviour” of mine substances. Finally, which substances are available to dogs in the air or on the soil surface above landmines?

### *Chemical characteristics of substances found in mines*

Table 1 gives a list of substances found in some of the most commonly used military explosives: TNT, DNT and RDX are present in almost all explosives.

The table tells only part of the story, and it is not appropriate to suggest that the substances most consistently present for dogs will be those that are most abundant in the vapour phase on these measurements, i.e. those with the highest vapour pressures. Availability for the dog depends on the combination of source release rates, and degradation and phase partitioning (including vapour pressure, water solubility and soil sorption) in soils. For example, 1,3-DNB has a high vapour pressure, but leakage is low and it does not sorb well to soils (Leggett *et al.*, 2001). Nor is it routinely found in measurements of the air above mines. The energetic materials in an explosive (TNT, RDX) have a much lower vapour pressure than, for example, the impurities DNT or DNB (Williams *et al.*, 1998).<sup>7</sup> Whether they are also less likely to be present in the vapour above a mine than the other substances depends on local circumstances, including how long the mine has been buried.

Fig. 2 shows that the transport of TNT or DNT from a buried landmine to the surface depends on various physical processes, such as diffusion, partitioning and evaporation (Webb and Phelan, 2000; Phelan and Barnett, 2001; Phelan *et al.*, 2001a). These processes are strongly affected by three factors: soil composition, temperature and soil moisture.

---

7. The following list gives vapour pressures for various substances found in landmines, as obtained from Williams *et al.* (1998). All values are given as Ng/L: RDX: 0.04, PETN: 0.09, HMX: 0.38, 2,4,6-TNT: 70, 2,4-DNT: 1440, 1,3-DNB: 1840. These values can change with temperature (Furton and Myers, 2001).

TNT and DNT are likely to be transported more slowly to the soil surface in dense clay compared to loose sandy soil due to sorption (Phelan and Barnett, 2001; Phelan *et al.*, 2001b). The colder the soil temperature, the less vapour is produced at the soil surface (Phelan and Barnett, 2001; Leggett *et al.*, 2001). Soil moisture affects the vapour levels of TNT and DNT in three ways. With dry soils, sorption is high and vapour levels are depressed. Upon wetting, the water displaces the TNT or DNT from the soil surfaces, causing much greater vapour levels (up to 10,000 times). However, with continued wetting (rain), the water will wash sorbed TNT or DNT from the soil surface, again decreasing the vapour levels (J. Phelan, pers. comm.).

| Military explosive | Main composition                 |
|--------------------|----------------------------------|
| C-2                | RDX + TNT + DNT + NC + MNT       |
| C-3                | RDX + TNT + DNT + Tetryl + NC    |
| C-4                | RDX + Polyisobutylene + Fuel oil |
| Cyclotol           | RDX + TNT                        |
| DBX                | TNT + RDX + AN + Al              |
| HTA-3              | HMX + TNT + Al                   |
| Pentolite          | PETN + TNT                       |
| PTX-1              | RDX + TNT + Tetryl               |
| PTX-2              | RDX + TNT + PETN                 |
| Tetryol            | TNT + Tetryl                     |

Table from Furton and Myers (2001).

Figure 2  
Chemical processes that affect TNT distributions around buried landmines or UXO

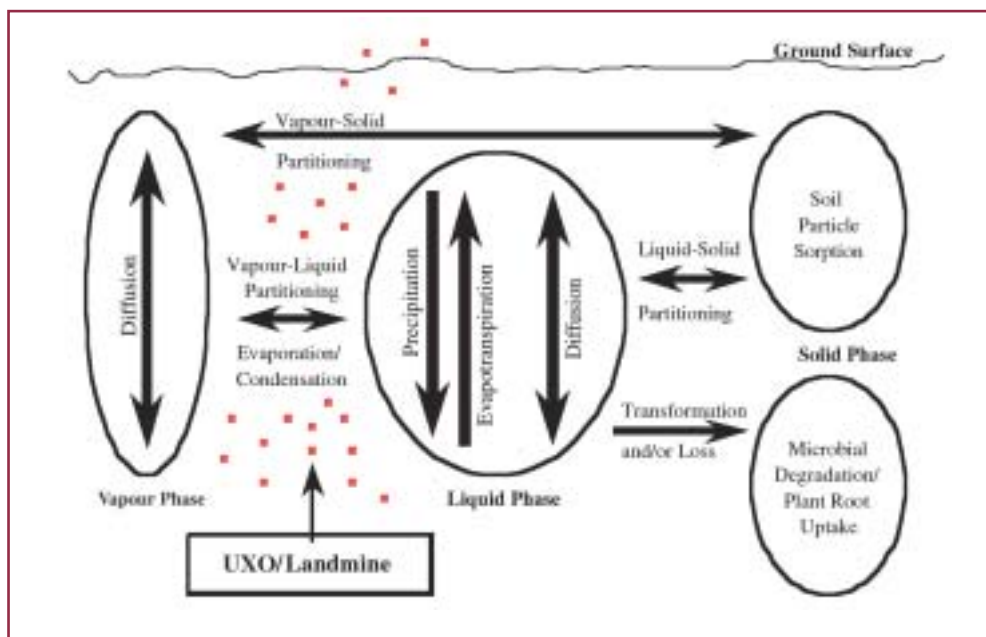

Figure reproduced from Phelan and Barnett (2001).

An additional conclusion from these results is that the strongest smell of a landmine does not necessarily have to be present directly above the mine. If, for example, heavy clay soil or a stone is situated above the mine in the ground, but there are other soil types to the side, the TNT and DNT molecules might be transported laterally, especially if there is a downslope component. They may then reach the surface at some distance from the point directly above the buried mine (M. Krausa, pers. comm.).

Environmental factors also affect another important process: the so-called biotransformation. TNT is not a stable substance, and TNT that leaks from a mine into the ground may be transformed into other, closely related substances. The half-life of mine substances (that is the time after which half the amount has been transformed into other substances) was determined as follows: 1.3 days for 2,4,6-TNT, 9.9 days for 1,3-DNB, 18 days for 2,6-DNT, and 26 days for 2,4-DNT (Miyares and Jenkins, 2000).<sup>8</sup> These values can vary, as the biotransformation of TNT is affected by temperature, moisture and the presence of certain microorganisms, which mediate the transformation (Karg and Koss, 1993; Phelan and Webb, 1998). Dry soil conditions, for example, limit biotransformation and allow accumulation of explosive residues on soils adjacent to the mine (James Phelan, pers. comm.).

### *Presence of mine substances in soil and vapour*

#### **Presence in the soil**

Researchers from the U.S. Army Corps of Engineers measured TNT, DNT and DNB concentrations in the soil at various distances from a buried landmine. It became obvious that the highest concentrations of all three chemicals were found under the mine (Table 2). The closer to the surface that samples were taken, the less chemical was available, and nothing was detected in many samples (George *et al.*, 2000). TNT was rarely detected (using laboratory detection systems) on the soil surface or up to 5 cm depth.

Table 2  
Concentrations of substances found at different distances from  
a TMA-5 landmine buried in 20 cm depth

| Substance | Concentrations at various distances from a buried<br>TMA-5 landmine (ug/kg) |        |         |          |            |
|-----------|---|--------|---------|----------|------------|
|           | Soil surface  | 0-5 cm | 5-10 cm | 10-15 cm | Under mine |
| 2,4,6-TNT | <d  | <d     | 10      | 8        | 873        |
| 2,4-DNT   | 52  | 6      | 17      | 150      | 5480       |
| 2-ADNT    | 49  | 14     | 28      | 207      | 3428       |
| 4-ADNT    | 41  | 14     | 29      | 163      | 2802       |
| 1,3-DNB   | <d  | <d     | <d      | <d       | 524        |

<d = not detectable (concentrations too low).

ADNT = Amino-DNT (an environmental transformation product of 2,4,6-TNT)

Table reproduced from George *et al.* (2000).

8. A series of 5.0-g replicate portions of soil from a research minefield at Fort Leonard Wood, Missouri, was fortified with 2,4,6-TNT, 2,4- and 2,6-DNT, and 1,3-DNB at about 0.5 mg/kg. Replicates were held at one of three temperatures ( $22 \pm 2$ ,  $4 \pm 2$ , or  $-4 \pm 2^\circ\text{C}$ ) in the dark for periods ranging from 4 hours to 30 days and were then extracted with acetonitrile. The extracts were analysed by reversed-phase HPLC to estimate the concentrations of the parent compounds and any detectable transformation products remaining. The values presented here were obtained at  $22^\circ\text{C}$ ; at lower temperatures the half-lives were considerably longer.

In the same study, the U.S. Army Corps of engineers collected more than 1,000 soil samples at the surface and at depth near buried TMA-5, TMM-1, PMA-1A, PMA-2, and Type 72 landmines.<sup>9</sup> Again, the chemicals detected most often on the surface were 2,4-DNT and two types of ADNT (2-ADNT and 4-ADNT). 2,4,6-TNT was mostly found around the buried mine, but not on the surface (Jenkins *et al.*, 2000). An additional result of this study was that the concentrations of the chemicals were much higher around TMA-5 and PMA-1A landmines (which have holes or gaps in the casing) than around TMM-1 and PMA-2 mines (which are well sealed).

Research by the US Army Corps of Engineers also showed that the type of soil that mines are buried in has to be considered: the surface of sandy soil contained much more DNT and DNB than the surface of clay soil (which has higher sorption), and TNT was only detectable in sandy soil in very low concentrations. Additionally, vapour concentrations of these chemicals were much lower in dry conditions than after rain — light rainfall therefore facilitates movement of vapour to the surface (Jenkins *et al.*, 1999), although heavier rains can have a flushing effect which removes mine substances.<sup>10</sup>

#### Presence in vapour

Two research organisations have sampled the vapour above buried landmines: samples were taken in Bosnia and Herzegovina and Cambodia by the Swedish research organisation FOI (A. Kjellström, pers. comm.; Kjellström and Sarholm, 2000), the other samples were taken in the U.S. (P. Waggoner, pers. comm., and at [www.vetmed.auburn.edu/ibds/frame.htm](http://www.vetmed.auburn.edu/ibds/frame.htm)). Neither detected TNT in the samples. In Bosnia, FOI found 2,4-DNT and 2,6-DNT, and in Cambodia they found these substances and also amino-DNT. In the U.S., the vapour above the landmine also seemed to contain only various forms of DNT and DNB, but not TNT. Both authors concluded that the sensitivity of the analytical methods was not high enough to detect any traces of TNT<sup>11</sup>, a point agreed by Jenkins *et al.* (2000), who estimated TNT vapour soil concentrations from soil residues, at about 0.94 pg/L (=0.094 ppt, below detection thresholds).

The U.S. Army Corps of Engineers sealed buried landmines in bags or submerged them in water, to show that temperature affects the vapour emerging from mines (see above). These tests also showed that 2,4-DNT was the principal component of the so-called “vapour-signature” above several types of landmines (Leggett *et al.*, 2001).

---

9. The study took place at a research minefield at Fort Leonard Wood, Missouri, in 1998 and 1999. Soil samples were extracted with acetonitrile and analysed by GC-ECD for nitroaromatic, nitramine, and aminonitroaromatic compounds.

10. The vapour was sampled above buried military grade TNT for one minute, in three types of soil (sand, silt and clay) and at three different levels of air moisture (dry, 2.1% and 3.1% moisture). Analysis after six days (storage was at 23°C) showed: in the samples from sandy soil, DNB and DNT were present in high concentrations, whereas TNT concentrations were 10-204 times lower in the three levels of moisture. In the samples from silt, concentrations of all three substances (DNT, DNB and TNT) were much lower, with again TNT having the lowest concentrations of all. In the samples from clay, only DNB was detectable (TNT and DNB not at all), and this also only in samples taken at 15% and 30% moisture (not those taken in dry air).

11. With respect to these results, there are measurement limitations to the quantities of chemicals that can be detected. Dogs clearly smell much lower quantities of mine substances than can be detected with present instruments. Mine substances are most likely present in much lower concentrations in the air or the soil than can be detected. More and more research is conducted to develop appropriate measurement apparatuses, and nowadays, a variety of analytical techniques are available for the detection of small amount of explosives. But so far, scientists cannot imitate the dog's nose completely.

### Presence on mine surfaces

The U.S. Army Corps of Engineers took chemical samples directly from the surface of four different types of landmines (Leggett *et al.*, 2000). The researchers found that in almost all samples, DNB and DNT were present in higher concentrations on the surface of all four types of mines than TNT (Table 3). The analyses also showed that the quantity of DNB, DNT and TNT varied considerably between different types of mines.

**Table 3**  
Surface concentrations of DNB, DNT, TNT and RDX found on landmines  
(samples taken with a sponge from the surface of each of 4 types of mine)

| Substance | Mean concentrations (ng/cm <sup>2</sup> ) found on surface of |      |      |      |
|-----------|---|------|------|------|
|           | PMA1A   | PMA2 | TMA5 | TMM1 |
| 1,3-DNB   | 9.0   | 1.3  | 3.1  | 7.3  |
| 2,4-DNT   | 4.8   | 0.9  | 6.1  | 11.0 |
| 2,4,6-TNT | 0.4   | 1.3  | 83.9 | 13.2 |
| RDX       | <d  | 1.2  | <d   | <d   |

<d = not detectable.

Table reproduced from Leggett *et al.* (2000).

## Discussion and conclusions

One of the clearest conclusions from this summary of research results is that dogs probably routinely use substances other than TNT to locate landmines no matter with what substances they were trained. This conclusion is supported by the following results:

- TNT almost always contains various by-products of the manufacturer and decomposition products, such as DNT and DNB.
- In moist soils, all of these substances are transformed, with the rate of this so-called biotransformation depending on humidity, temperature and the presence of micro-organisms.
- Behavioural testing indicated that the constituent of TNT most likely to evoke a response in the dogs is 2,4-DNT, and not TNT itself. DNT thus seems to be important in the so-called “detection signature” for a landmine.
- TNT has a much lower vapour pressure than many of its associated contamination and decomposition products, although the effects on relative availability of TNT at the soil surface or in the air above a landmine are complex.
- Two research organisations could not detect any TNT in the air above a landmine, but detected DNT and DNB (although the relatively high detection thresholds of the machines mean that TNT was probably still available in these studies, and the Auburn result, indicating the remarkable ability of dogs to pick out weak targets from a noisy background, is relevant here).
- One study found very little TNT on the surface of two types of mines.
- In one study at the IBDS, some dogs that were trained on TNT had difficulties detecting whole PMA1A landmines.

Although some mine detection dogs are trained specifically using TNT, current results suggest that they should not be trained on TNT alone, or at least some variation in the source and quality of the TNT used is desirable. A qualification of this comment is

that without laboratory support it is difficult to obtain “pure” TNT, as TNT will always contain breakdown and contamination substances. In reality, dogs trained using “pure” TNT will probably be trained on a bouquet of substances, potentially with an emphasis on DNT. Recent results from Sandia support that implication, as dogs in South Africa trained on “pure” TNT had no difficulty detecting DNT (J. Phelan, pers. comm.).

Detectability of TNT for dogs varied with its origins. Therefore, mines from different sources (or even of different batches from the same source?) are likely to smell different. As well, local climate and micro-organisms in the soil will influence odour availability. For this reason, it is advisable to train dogs in the region where they will be deployed, and to undertake regular maintenance training of detection skills.

A dog may not necessarily use the explosives in a mine (TNT, RDX, Picric acid) and/or their impurities (DNT, DNB) as the only detection cues. A mine also consists of a metal or plastic housing, which may contain painted stainless steel, polyvinylchlorides and polystyrene. The paint itself may seal in surface contaminants which are released when the mine is first buried. Additives such as waxes, plasticizers (=softeners), solvents and oils may also be present. It is likely that all of these substances impart their own quality on the resulting vapour composition of the landmine, further supporting the principle of training dogs for bouquets of local mines, even if the main training programme uses TNT.

It also seems likely that the vapour composition of a mine will change with time, as the more volatile components such as organic solvents become exhausted. Of course, such changes may be short-term and the vapour could have stabilised by the time the mine is deployed. Research at the IBDS indicated that the plastic case of a landmine was not detected by dogs. However, some operational organisations train using mine cases from discarded mines, and the dogs find them consistently (K. Muftic, pers. comm.). Such cases presumably provide residues from TNT and related chemicals. Many organisations train specifically with TNT because it is the most universal component of landmines, the aim being to produce a dog that should find any mine in any deployment situation. “Tuning” of the dog in the deployment theatre ensures that the dog can detect the mines most likely to be found there. Such tuning can take up to several weeks, and is essentially a generalisation training that links previously trained skills to local vapour signatures. Clearly, much remains to be learned about these issues.

Unfortunately, although there is now considerable knowledge about the effects of environmental factors on odour availability, too little is known about how local climatic factors affect the detectability of landmines for dogs. The GICHD is concurrently conducting a research project in Afghanistan, and Bosnia and Herzegovina where this issue is addressed, in cooperation with the Sandia National Laboratories (U.S.), FOI (Sweden), and local operational organisations. The aim of this research is to develop guidelines about climatic conditions under which mine dog operations should be suspended, because detection thresholds are too low.

An issue that has not been resolved is the role of particles (dust) in the detection process. In dry, sandy environments such as Afghanistan, the low soil moisture decreases the availability of explosive molecules in vapour (because of increased vapour-solid sorption at the soil surface). Nevertheless mine dogs still find mines. It may be that explosive molecules are strongly adhered (or sorbed) to soil particles, which are suspended in the air by low speed winds or which are activated into motion



by the sniffing action of the dog. Upon reaching the mucus in the dog's nose, where it is much more humid than outside, the combined soil particle and explosive molecule may separate, allowing the molecule to move through the mucus to the receptor cells (Chapter 2, Part 2; J. Phelan, pers. comm.).

The dynamics of this hypothesised process have not been investigated. Many explosives, and especially TNT and DNT, have a very high tendency to stick to any surface, and it is not clear how moisture adjusts the stability of that bond (M. Krausa, pers. comm.). The "sticking" principle is being exploited in the concept now called REST (Remote Explosive Scent Tracing), in which minefields are vacuumed through a filter, and the filter is offered to dogs to determine if mines are present (Chapter 2, Part 2). Again, much remains to be learned about the processes here. However, of particular relevance to dog trainers is that TNT and related molecules will easily contaminate training tools, thus cleanliness and caution are essential when producing materials for training discrimination skills.

Central to the problem of learning more about the processes affecting the detection abilities of dogs is the mismatch between the extraordinary ability of dogs to detect mines, and the technical limits to current laboratory measurement techniques. The detection ability of dogs remains better than machines by some or even many orders of magnitude. Ultimately, the only available device against which the skills of a dog can be compared is another dog. Thus truly independent measurement of odour availability, allowing experimental determination of the limits to the skills of dogs, is not yet available. And there is no reason to expect it in the short to medium term. Despite that constraint, much is being learned because of support from the dogs themselves.

---

## Acknowledgements

We thank the following scientists for providing results and unpublished reports: James M. Phelan from the Sandia National Laboratories and his colleagues, and Paul Waggoner from the Institute for Biological Detection Systems at Auburn University and his colleagues. We also thank Michael Krausa from the Fraunhofer Institute for Chemical Technology in Germany for providing us with a valuable summary of research results. Comments from Håvard Bach, Paddy Blagden, James Phelan and Paul Waggoner considerably improved earlier drafts of this report.

---

## References

- Cicoria, M. (1999)  
*Odor detection signatures of the dog for Trinitrotoluene (TNT) and the generalization of detection responses across other TNT samples*, Masters thesis, Institute for Biological Detection Systems, Auburn University, Alabama.
- Furton, K.G., and L.J. Myers (2001)  
“The scientific foundation and efficacy of the use of canines as chemical detectors for explosives”, *Talanta* 54:487-500.
- Garner, K.J., L. Busbee, P. Cornwell, J. Edmonds, K. Mullins, K. Rader, J.M. Johnston and J.M. Williams (2000)  
*Duty cycle of the detection dog: A baseline study. Final Report*, Federal Aviation Administration, Washington D.C.
- George, V., T.F. Jenkins, J.M. Phelan, D.C. Legget, J. Oxley, S.W. Webb, J.H. Miyares, J.H. Craig, J. Smith and T.E. Berry (2000)  
“Progress on determining the vapor signature of a buried landmine”, in *Detection and Remediation Technologies for Mines and Minelike Targets V*, Proceedings of SPIE, Vol. 4038.
- IBDS/DARPA (2001)  
*Summary of IBDS (Institute for Biological Detection Systems) Activities in Support of the DARPA Land Mine Detection Technology Program*, unpublished report.
- Jenkins, T.F., D.C. Legget and T.A. Ranney (1999)  
*Vapor signature from Military Explosives – Part I: Vapor transported from buried military-grade TNT. Cold Regions Research and Engineering Laboratory*, Special Report 99-21, December.
- Jenkins, T.F., M.E. Walsh, P.H. Miyares, J.A. Kopczyński, T.A. Ranney, V. George, J.C. Pennington and T.E. Berry Jr. (2000)  
*Release of Explosive-Related Vapors from Land Mines. Cold Regions Research and Engineering Laboratory*, Technical Report ERDC TR-00-5, August.
- Johnston, J.M. (1998)  
*Enhanced canine explosives detection*, unpublished report, Institute for Biological Detection Systems, Auburn University, Alabama.
- Johnston, J.M., J.M. Williams, L. Busbee, P. Cornwell and J. Edmonds (2000)  
*Durability of canine odor discriminations: implications for refresher training*, unpublished interim report, Institute for Biological Detection Systems, Auburn University, Alabama.
- Karg, F.P., and G. Koss (1993)  
“Untersuchungen zur Umweltchemie, Kontaminationserkundung und –bewertung”, *Zeitschrift für Umweltchemie* 5:182.
- Kjellström, A.H., and L.M. Sarholm (2000)  
“Analysis of TNT and related compounds in vapor and solid phase in different types of soil”, in *Detection and Remediation Technologies for Mines and Minelike Targets V*, Proceedings of SPIE, Vol. 4038.
- Leggett, D.C., T.F. Jenkins, A.W. Hogan, T. Ranney and P.H. Miyares (2000)  
*External contamination of landmines by organic nitro-compounds*, U.S. Army Corps of Engineers, Technical Report ERDC/CRREL-TR-00-2, March.
- Leggett, D.C., J.H. Cragin, T.E. Jenkins and T. Ranney (2001)  
*Release of Explosive-Related Vapors from Land Mines*, Cold Regions Research and Engineering Laboratory, Technical Report ERDC/CRREL TR-01-6, February.

- Lieberman, D.A. (2000)  
*Learning – Behavior and Cognition*, Wadsworth/Thomas Learning, Belmont.
- Miyares, P.H., and T.F. Jenkins (2000)  
*Estimating the Half-Lives of Key Components of the Chemical Vapor Signature of Land Mines. Cold Regions Research and Engineering Laboratory*, Technical Report ERDC/CRREL TR-00-17, September.
- Phelan, J.M., and S.W. Webb (1998)  
Simulation of the Environmental Fate and Transport of Chemical Signatures from Buried Landmines, *Proceedings of SPIE Conference on Detection and Remediation Technologies for Mines and Minelike Targets III*, Orlando, FL., April.
- Phelan, J.M., and J.L. Barnett (2001)  
*Phase partitioning of TNT and DNT in soils*, Sandia National Laboratories Report SAND2001-0310, Albuquerque, New Mexico, February.
- Phelan, J.M., S.W. Webb, P.J. Rodacy and J.L. Barnett (2001a)  
*Environmental Impact to the Chemical Signature Emanating from Buried Ordnance - Final Report*, Project CU-1094, Sandia National Laboratories Report SAND 2001-2902, September.
- Phelan, J.M., S.W. Webb, M. Gozdor, M. P. Cal and J.L. Barnett (2001b)  
“Effect of Soil Wetting and Drying on DNT Vapor Flux – Laboratory Data and T2TNT Model Comparisons”, *Proceedings of SPIE Conference on Detection and Remediation Technologies for Mines and Minelike Targets VI. April 16-20, 2001*.
- Waggoner, L.P., M. Jones, M. Williams, J.M. Johnston, C. Edge and J.A. Petrousky (1998)  
*Effects of extraneous odors on canine detection*, SPIE 3575:355-362.
- Webb, S.W., and J.M. Phelan (2000)  
“Effect of diurnal and seasonal weather variations on the chemical signatures from buried landmines/UXO”, in *Detection and Remediation Technologies for Mines and Minelike Targets V*, Proceedings of SPIE, Vol. 4038.
- Williams, M., J.M. Johnston, M. Cicoria, E. Paletz, L.P. Waggoner, C.C. Edge and S.F. Hallowell (1998)  
*Canine detection odor signatures for explosives*, SPIE, 3575:291-301.
- Williams, M., J.M. Johnston, L.P. Waggoner and M. Cicoria (1997)  
“Canine Substance Detection: Operational Capabilities”, in *Proceedings of the AVIAN Security Conference*.

## Chapter 5 Odour detection: the theory and the practice

# Part 2 Chemical sensing for buried landmines: fundamental processes influencing trace chemical detection

*James M. Phelan and Stephen W. Webb*

### Abstract

Mine detection dogs have a demonstrated capability to locate hidden objects by trace chemical detection. Because of this capability, demining activities frequently employ mine detection dogs to locate individual buried landmines or for area reduction. The conditions appropriate for use of mine detection dogs are only beginning to emerge through diligent research that combines dog selection/training, the environmental conditions that impact landmine signature chemical vapours, and vapour sensing performance capability and reliability. This report seeks to address the fundamental soil-chemical interactions, driven by local weather history, that influence the availability of chemicals for trace chemical detection. The processes evaluated include: landmine chemical emissions to the soil, chemical distribution in soils, chemical degradation in soils, and weather and chemical transport in soils. Simulation modeling is presented as a method to evaluate the complex interdependencies among these various processes and to establish conditions appropriate for trace chemical detection. Results from chemical analyses on soil samples obtained adjacent to landmines are presented and demonstrate the ultra-trace nature of these residues. Lastly, initial measurements of the vapour sensing performance of mine detection dogs demonstrates the extreme sensitivity of dogs in sensing landmine signature chemicals; however, reliability at these ultra-trace vapour concentrations still needs to be determined. Through this compilation, additional work is suggested that will fill in data gaps to improve the utility of trace chemical detection.

---

## Note

The authors are employed at the Environmental Technology Department of Sandia National Laboratories, Albuquerque, New Mexico 87185 and Livermore, California 94550. Sandia is a multiprogramme laboratory operated by Sandia Corporation, a Lockheed Martin Company, for the United States Department of Energy under Contract DE-AC04-94AL85000. This chapter was sponsored by the Geneva International Centre for Humanitarian Demining (GICHD), under the technical direction of Håvard Bach.

This report was originally issued in May 2002 by Sandia National Laboratories as report number SAND2002-0909. This work was prepared as an account of work sponsored by an agency of the United States Government. Neither the United States Government, nor any agency thereof, nor any of their employees, nor any of their contractors, subcontractors, or their employees, make any warranty, express or implied, or assume any legal liability or responsibility for the accuracy, completeness, or usefulness of any information, apparatus, product, or process disclosed, or represent that its use would not infringe privately owned rights. Reference herein to any specific commercial product, process, or service by trade name, trademark, manufacturer, or otherwise, does not necessarily constitute or imply its endorsement, recommendation, or favouring by the United States Government, any agency thereof, or any of their contractors or subcontractors. The views and opinions expressed herein do not necessarily state or reflect those of the United States Government, any agency thereof, or any of their contractors.

---

## 1. Introduction

Landmines contain energetic chemicals that emit odours (chemical signatures) that are barely perceptible by humans. However, dogs can be specially trained to scent and indicate the presence of explosive chemical odours. The first records of the effect of environmental factors on landmine odours occurred during the 1939-45 war, where the Finnish Armed Forces describe the importance of soil conditions on successful mine dog detection work (unknown author, circa 1940s, P. Soderburg translation).

The external physical conditions that affect explosive vapours in soils can now be described in much detail with advances in knowledge from agriculture, chemistry, soil physics, meteorology and computer science. There have been many contributions from basic research, applied research, and field anecdotes. The environment is complex, and the impact of the environment on the chemical odours from buried landmines is even more complicated. Individual phenomena have been explored in various levels of detail. The combination of external physical conditions (the environment), soil-chemical interactions, and individual landmine characteristics are now being explored with computer simulation tools for comparison to trace chemical detection methods including mine detection dogs.

This report seeks to bring together the current state of knowledge for each of the important individual phenomena and demonstrate the utility of computer simulation as a tool to evaluate the complex combination of environmental factors affecting the chemical signature from buried landmines. Computer simulations can explore the impacts on the chemical vapours from specific environmental situations for comparison to the vapour sensing thresholds of mine detection dogs. With this knowledge, mine action programmes can establish optimal operating conditions for the performance characteristics of mine detection dogs within their programme. This analysis may establish marginal conditions based on environmental factors, landmine type and/or dog performance to limit field activities. However, one must recognise the limitations of computer simulation results and monitor actual environmental effects on mine dog detection performance.

This report is a compendium of relevant material on the nature of the chemical signature from buried landmines with emphasis on how individual and interdependent soil chemodynamic processes affect the ability of the dog to locate buried landmines. Each section discusses a single topic, with subsequent sections contributing more information, resulting in a comprehensive analysis of landmine trace chemical detection. Each section introduces the topic and is followed by key information in bullet form that is described in more detail in the balance of the chapter.

## 2. Numbers in chemistry

The intent of this report is to summarise information on the chemical properties of the explosive compounds in landmines that affect detection by mine detection dogs. Our analysis seeks to identify environmental factors that impact the dogs' ability to recognise landmine chemical odours. Thus, the amount or level or concentration becomes important, and we must lay a foundation for analysis in quantitative terms.



### Key information

- Chemical sensing for landmines involves extremely small quantities that require specialized notation when discussing quantitative values.
- Terms used to describe the concentration of chemicals in soil, water and air have special units and one must have consistent units when comparing values.

### Scientific notation

Because of the extremely large range in the numbers found with this problem, one must use scientific notation to describe quantities. Table 1 shows the scientific notation, decimal notation, name and symbols for the most common values used in this report.

| Scientific notation | Decimal notation  | Name  | Symbol |
|---------------------|-------------------|-------|--------|
| $10^6$              | 1,000,000         | mega  | M      |
| $10^3$              | 1,000             | kilo  | k      |
| $10^1$              | 10                | deca  | d      |
| $10^0$              | 1                 |       |        |
| $10^{-3}$           | 0.001             | milli | m      |
| $10^{-6}$           | 0.000001          | micro | μ      |
| $10^{-9}$           | 0.000000001       | nano  | n      |
| $10^{-12}$          | 0.000000000001    | pico  | p      |
| $10^{-15}$          | 0.000000000000001 | femto | f      |

### Concentrations

Organic chemicals in the environment can dissolve or partition into the air, water and soil. Vapour is the term used to describe a chemical in air. Solute is the term used to describe a chemical in water. Residue is the term used to describe a chemical in soil. A chemical, such as TNT found in landmines, can transfer between the air, water and soil until it reaches equilibrium — a condition where all forces are balanced and change is minimal. A more detailed description of how landmine chemicals partition between air, water and soil particles in a soil system is presented below in Section 5: *Chemical distribution in soils*.

The term concentration is used to describe how much chemical is present in a given amount of air, water or soil. In water, the units are typically given as mass of chemical per volume of water (m/v) because the density of water (mass per unit volume, about 1 g/mL) is relatively constant. The most common units are milligram of chemical per litre of water (mg/L) or microgram of chemical per litre of water (μg/L). In soil, the units are typically given as mass of chemical per mass of soil (m/m), because the density of soil (1 to 2 g/mL) changes slightly depending on the compaction of the soil. The most common units are microgram of chemical per gram of soil (μg/g). However, for explosive residues in soil from landmines, the values are much lower and we more often use nanograms of chemical per gram of soil (ng/g). For air, the units are typically given as mass of chemical per volume of air (m/v). In our work, we typically use units of nanograms of chemical per litre of air (ng/L).

There are several other terms used to describe the concentration of a chemical in air, water or soil. These use the units of moles, which is a measure of the number of molecules. There is a constant number of molecules per mole, that is  $6E23$  (i.e.  $6 \cdot 10^{23}$ ), and is termed Avogadro's number. Most often, moles are used in the context of water concentration, such as moles of chemical per litre of water (moles/L).

The most common term used to express concentration is the "parts per" notation, but it is frequently misused. For soil, a ng/g is parts per billion (ppb) because a nanogram is 1 billion ( $10^9$ ) less than a gram. For water, a mg/L is parts per million (ppm) because water has a density of about 1 g/mL, so a mg/L can be converted to mg of chemical per gram of water (mg/g) and a micro is 1 million ( $10^6$ ) less than a gram.

For air, the conversion is more complicated because air is usually measured in volume, and part per notation for air is on a volume of chemical/volume of air basis. Fortunately, molecules of gas or vapour occupy a known volume — about 22.4 L/mole at 1 atmosphere pressure and  $0^\circ\text{C}$  (24.5 L/mole at sea level (1 atm) and  $25^\circ\text{C}$ ). However, now the atmospheric pressure, temperature and molecular weight of the chemical of interest must be known. Equation [1] shows how to convert ng of chemical per litre of air (ng/L) to parts per trillion for TNT (molecular weight of 227 g/mole)—the vapour unit we will be using the most frequently in this report.

$$ppt = \frac{ng}{L} \cdot \frac{24.5L}{mole} \cdot \frac{mole}{227g} \cdot \frac{g}{10^9} \cdot 10^{12} \quad [1]$$

This calculation shows for TNT (at sea level atmospheric pressure of 1 atm and  $25^\circ\text{C}$ ) that 1 ng/L is 110 ppt. For DNT at sea level and  $25^\circ\text{C}$ , 1 ng/L is 135 ppt because the DNT molecular weight is 182 g/mole. Table 2 shows the most common units of concentration for water and soil for easy reference. Table 3 shows the sequence in "parts per" notations to describe lower and lower concentrations.

| Table 2<br>Water and soil concentration units |             |                         |                         |
|---|-------------|-------------------------|-------------------------|
|   |             | Parts per million (ppm) | Parts per billion (ppb) |
| Water   | Mass/volume | mg/L                    | mg/L                    |
| Soil  | Mass/mass   | mg/g                    | ng/g                    |

| Table 3<br>"Parts per" notation |                        |                    |        |
|---------------------------------|------------------------|--------------------|--------|
| Scientific notation             | Decimal notation       | Term               | Symbol |
| 1 in $10^6$                     | 1 in 1,000,000         | Parts per million  | ppm    |
| 1 in $10^9$                     | 1 in 1,000,000,000     | Parts per billion  | ppb    |
| 1 in $10^{12}$                  | 1 in 1,000,000,000,000 | Parts per trillion | ppt    |

For these extremely low concentrations, there must be at least one whole molecule per amount of air, water or soil for the concentration numbers to be detectable for a specified sample size. For example, with TNT one molecule weighs only  $4E-22$  ( $4 \cdot 10^{-22}$ ) grams. Thus, a 1 g soil sample with 1 ng/g TNT residue will have one trillion

( $10^{12}$ ) molecules of TNT. And, a 100 mL volume of air with 1 ppt (0.01 ng/L) will have one billion ( $10^9$ ) molecules of TNT. Table 4 shows these values for soil, water and air. Conversely, Table 5 shows the concentrations for only 1 molecule in a specified volume of soil, water and air.

| Media | Sample size | Concentration | Number of molecules        |
|-------|-------------|---------------|----------------------------|
| Soil  | 1 gram      | 1 ng/g        | One trillion ( $10^{12}$ ) |
| Water | 1 mL        | 1 mg/L        | One trillion ( $10^{12}$ ) |
| Air   | 100 mL      | 1 ppt         | One billion ( $10^9$ )     |

| Media                        | Mass units      | "parts per" units |
|------------------------------|-----------------|-------------------|
| 1 molecule per gram of soil  | $10^{-13}$ ng/g | $10^{-13}$ ppb    |
| 1 molecule per mL of water   | $10^{-13}$ mg/L | $10^{-13}$ ppb    |
| 1 molecule per 100 mL of air | $10^{-12}$ ng/L | $10^{-10}$ ppt    |

### Molecular structure and formulas

This report will also discuss the names of several important chemicals linked to the chemical odour signature from military grade TNT. Fig. 1 shows some of these important chemical structures with numbering schemes for the atoms in each molecule. For example, TNT is known specifically as 2,4,6-trinitrotoluene. There is a nitro group ( $\text{NO}_2$ ) at the carbon 2, 4 and 6 positions of the toluene molecule. Section 3 will present more information on the types and names of the many chemicals involved in the manufacture of TNT.

Figure 1  
Chemical structures for compounds important to landmine chemical sensing

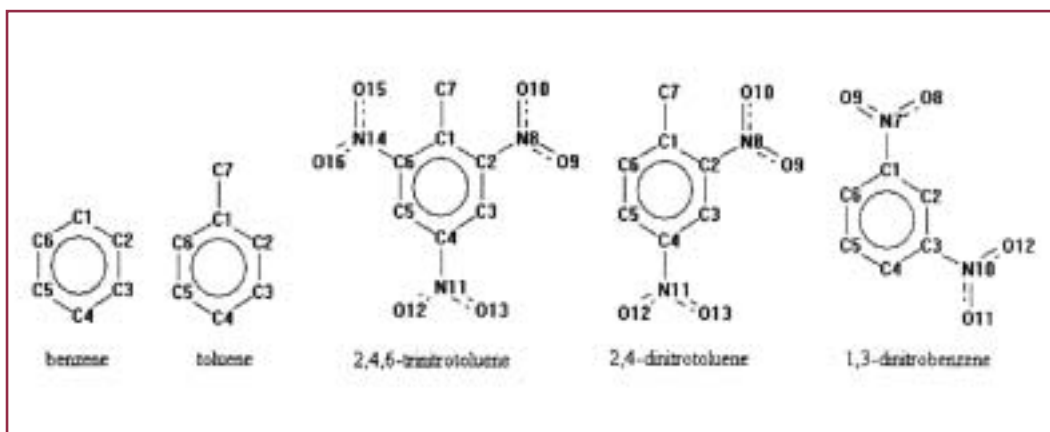

### 3. Target chemical compounds

The observation that dogs can detect buried landmines by odour recognition has been described by many demining personnel. Whether the odour recognition comes from a single chemical or a mixture, or whether it comes from the explosives in the landmine or from the plastic case or the paint of a metal mine, is not known with certainty. Much of the evidence, however, points to the dog recognising a chemical signature from the explosive main charge of the landmine. This section presents information on the complex mixture of chemicals in TNT, as TNT represents the main charge explosive in the majority of landmines in the world.

#### *Key information*

- TNT manufacturing processes vary around the world, which produce a variety of impurities at various levels.
- The three most important vapour constituents of military grade TNT include: 2,4,6-TNT; 2,4-DNT; and 1,3-DNB.

#### *TNT manufacturing impurities*

TNT is manufactured by nitration of toluene with a nitric acid solution. The toluene is derived from the distillation of crude oil, and may have impurities such as benzene. The synthesis process favours the production of 2,4,6-trinitrotoluene, but other isomers (chemicals with same molecular formula, but with different structures) can be formed in smaller quantities. Different TNT production and purification processes will produce different amounts of isomeric impurities. Table 6 shows the impurities present before and after purification for the American continuous countercurrent treatment of TNT with anhydrous sodium sulfite (Kaye, 1980).

#### *Vapour signature above bulk TNT*

Impurities present in solid phase TNT are only the starting point in the analysis of which chemicals are target odours for the dogs. Release of the chemical odours may follow several paths including dissolution into water that penetrates into the landmine and permeation through the plastic case into the soil. Permeation is a vapour-driven process that makes the identification of vapour phase compounds from TNT very important. Table 7 shows a comparison of the solid and vapour phase impurities of TNT and DNT measured in military grade TNT. While the majority of the solid phase contains the 2,4,6 isomer of TNT, there are still small amounts of the other isomers of TNT as well as the many isomers of DNT. This demonstrates that military grade TNT vapour contains a mixture of compounds that dogs can use as cues to recognise buried landmines.

**Table 6**  
Impurities present in TNT by continuous nitration and purification

| Compound  | Approximate maximum nominal concentration (%) |          |
|---|---|----------|
|   | Crude   | Finished |
| 2,4,5 TNT   | 2.50  | 0.30     |
| 2,3,4 TNT   | 1.75  | 0.20     |
| 2,3,6 TNT   | 0.50  | 0.05     |
| 2,3,5 TNT   | 0.05  | 0.05     |
| 2,6 DNT   | 0.25  | 0.25     |
| 2,4 DNT   | 0.50  | 0.50     |
| 2,3 DNT   | 0.05  | 0.05     |
| 2,5 DNT   | 0.10  | 0.10     |
| 3,4 DNT   | 0.10  | 0.10     |
| 3,5 DNT   | 0.01  | 0.01     |
| 1,3 Dinitrobenzene (DNB)                            | 0.02  | 0.02     |
| 1,3,5 Trinitrobenzene                               | 0.15  | 0.10     |
| 2,4,6 Trinitrobenzyl alcohol                        | 0.25  | 0.25     |
| 2,4,6 Trinitrobenzaldehyde                          | 0.25  | 0.25     |
| 2,4,6 Trinitrobenzoic acid                          | 0.50  | 0.05     |
| a-Nitrato-2,4,6 TNT                                 | 0.10  | 0.10     |
| Tetranitromethane                                   | 0.10  | None     |
| 2,2'-Dicarboxy-3,3',5,5'-<br>tetranitroazoxybenzene | 0.35  | 0.05     |
| 2,2',4,4',6,6'-Hexanitrobibenzyl                    | None  | 0.40     |
| 3-Methyl-2',4,4',6,6'-<br>pentanitrodiphenylmethane | None  | 0.40     |
| 3,3',5,5'-Tetranitroazoxybenzene                    | None  | 0.01     |

From: Kaye (1980).

**Table 7**  
Solid and vapour phase composition of military grade TNT

| Compound         | Solid phase composition (%) | Vapour phase composition (%) |
|------------------|-----------------------------|------------------------------|
| 2,4,6 TNT        | 99.80                       | 58                           |
| 2,3,5 TNT        | 0.08                        | Trace                        |
| 2,3,4 TNT        | 0.02                        | 3                            |
| 2,4 DNT          | 0.08                        | 35                           |
| 2,5 DNT          | <0.01                       | 4                            |
| 3,5 DNT          | <0.01                       | Trace                        |
| 3,4 DNT          | Trace                       | Trace                        |
| 2,6 DNT          | Trace                       | Trace                        |
| Other impurities | None detected               | Not analysed                 |

From: Murrman *et al.* (1971).

In an evaluation of eight U.S. and 14 foreign military-grade TNT samples, headspace vapor analysis quantified the prevalence of the various isomers of TNT and DNT (Leggett *et al.*, 1977). There were also two unknowns that were found, which could not be identified. This work showed that each TNT source material contained a variable mixture of these isomers. In some samples, certain isomers of TNT or DNT were not detectable. This work also showed that upon average, the 2,4-DNT was about 10 to 30 times greater in vapour concentration than 2,4,6-TNT.

Table 8 shows more recent work with similar results for 2,4-DNT, but also showed a compound not previously looked for or measured — 1,3-DNB (Jenkins *et al.*, 2001). The vapour concentration of 1,3-DNB was present at levels near or exceeding that of 2,4-DNT, indicating that this compound may also be important in the chemical signature for mine detection dogs.

| Source of explosive      | Headspace vapour concentration (ng/L) at 22°C |         |           |
|--------------------------|---|---------|-----------|
|                          | 1,3-DNB                                       | 2,4-DNT | 2,4,6-TNT |
| US Military 1966 (TNT)   | 350   | 550     | 70        |
| Yugoslavian PMA-1A (TNT) | 4600  | 1,400   | 78        |
| Yugoslavian PMA-2 (TNT)  | 970   | 280     | 77        |

From: Jenkins *et al.* (2001).

This effort also examined the influence of temperature (-12 to 31°C) on the headspace vapour concentrations. Seven compounds were found: 1,4-DNB; 1,3-DNB; 2,5-DNT; 1,2-DNB; 2,4-DNT; 3,5-DNT; and, 2,4,6-TNT. Of the impurities, all were found to increase exponentially with temperature (as expected), and the 1,3-DNB and the 2,4-DNT were always found at the greatest concentration.

### Summary

The solid phase composition of TNT has been shown to be a mixture containing mostly 2,4,6-TNT with a large number of trace impurities. The headspace vapour composition of TNT also contains this mixture of compounds, but the concentrations of some of the impurities exceed that of TNT by a factor of 10 to 100. What cues the dogs may use to recognise buried landmines may involve one or many of these chemical compounds, but if recognition is concentration dependent, then what we understand about the environmental impacts on the levels of 2,4,6-TNT (i.e. TNT), 2,4-DNT (i.e. DNT) and 1,3-DNB (i.e. DNB) in soils will provide a guide to the impacts on the entire bouquet of odours.

## 4. Landmine chemical emissions

In Section 3, chemical analytical tests showed that there were many chemicals derived from the TNT manufacturing processes that might be used as cues by mine detection dogs. In this section, the evaluation will focus on the three most prevalent explosive chemical signature compounds (TNT, DNT and DNB) found in the vapour from military grade TNT. Presence in the vapour is important, because this is the main form in which chemical emissions occur for most landmines.



### Key information

- Transfer of landmine chemicals to soil involves both leakage and permeation (both together are termed landmine flux). Leakage occurs through openings in the case. Permeation occurs by vapour diffusion through the thickness of the plastic material.
- Composition of the plastic case material makes a significant impact on the emissions into soils — hard plastics (e.g. PVC) permeate less (at least 30 times) landmine signature chemicals than flexible materials (e.g. rubber).
- Higher temperatures cause higher flux — flux is exponential [ $e^{0.11(°C)}$ ]; e.g. 1.7 times more for a change of 5°C, 3 times more for a change of 10°C, and 9 times more for a change of 20°C.
- Landmine flux is greater into water than into air (about 5 times more). Measurements are needed to determine how soil wetness impacts landmine flux.
- Painted steel landmines have surface contamination of landmine signature chemicals in the paint that is depleted over a short, but unknown, period of time. Permeation through the steel does not replenish the chemical signature, preventing chemical sensing for these types of landmines.
- Whole landmine flux testing provides the best measure of landmine chemical signature release to soils; however, very few of these tests have been performed to date.

### Leakage and permeation

Landmine flux describes two principal methods on how explosive chemical signatures escape into the soil. Permeation describes the rate at which a gas or vapour passes through a polymeric material (plastic). Permeation does not occur through metals such as steel. Leakage is the rate at which gases or vapours pass through an opening or crack. For this analysis, data for the combined total transfer of chemical signature to the soil is needed, whether from permeation or leakage.

There are many types of landmines, with many materials and methods of construction that contribute to the overall chemical transfer rate. The explosive main charge may be open to the environment, such as the hinged box mine (Fig 2. PMA-1A) where mass transfer is mostly from leakage. For other landmines that are encapsulated in a plastic case (Fig. 3. PMA2), permeation controls the mass transfer rate. Some mines have small holes (Fig. 4. TMA-5), which allow vapours a direct escape path to the soil. These openings also provide a path for direct contact of the explosive main charge package with water, such as with an extended rainfall, which can release a large amount of chemical to the soil.

For the mines with such openings, the explosive main charge may be coated (Fig. 5. TMA-5 with bitumen) or wrapped (Fig. 2. PMA1-A with wax paper) to prevent gross damage to the explosive due to contact with soil water. The amount of chemical that can dissolve into water is much, much greater than the amount that can vaporise into the same volume of air (discussed in more detail in Section 5: *Chemical distribution in soils*), so both pathways must be considered in this analysis.

The explosive main charge that is encapsulated in a plastic case is not synonymous with being well sealed — plastics are permeable, allowing gases and vapours to

Figure 2  
PMA-1A Landmine hinged box style and wax paper coating



Figure 3  
PMA-2 anti-personnel landmine and fuse



Figure 4  
Base of TMA 5 showing holes



Figure 5  
Coating on TMA-5 main charge explosive



migrate into and through the material. The factors that affect permeation include the type of polymer, physical state of the polymer, the nature of the penetrating gas or vapour, and the environmental conditions. Landmines are constructed from several types of plastics; however, the details on composition, additives and manufacturing processes are not known. Table 9 lists typical plastic materials used in the housings for landmines.

**Table 9**  
Plastics used in landmines

| Name                | Acronym |
|---------------------|---------|
| Bakelite (phenolic) | BAK     |
| Polyvinyl chloride  | PVC     |
| Polystyrene         | PS      |
| Polypropylene       | PP      |
| Polyethylene        | PE      |
| High density PE     | HDPE    |
| Low density PE      | LDPE    |
| Natural rubber      | NR      |
| Synthetic rubber    | SR      |

Plastics are materials made from long threads of stable chemicals called polymers. The polymer threads can crosslink with other polymer threads, creating a web-like mat. Permeation of gases and vapours through this mat occurs by a process called vapour diffusion. On the inside of the landmine, the solid explosive main charge releases vapours, which become absorbed into the polymer mat. The amount of chemical that resides in the polymer is called the solubility (same term is used to describe the amount of chemical that dissolves in water). These molecules are pushed by new molecules released from the solid explosive. Eventually, the explosive vapour exits (evaporates) from the outside of the landmine into the soil system. The rate at which the molecules can move through the polymer is termed diffusivity. In the simplest example, permeation is a function of how much chemical is absorbed in the polymer (solubility) and the rate at which it can move through the polymer (diffusivity). The driving force is the difference in concentration from the inside of the mine compared to the outside (e.g. the diffusion gradient). The driving force increases with increased temperature, because at higher temperatures, the solid explosive produces a greater concentration of vapour.

The nature of the monomer (single unit of the polymer, e.g. vinyl chloride in PVC) used to build the polymer affects the permeability. A structural arrangement of a polymer that creates dense packing decreases permeability. The simpler the structure, the better the packing and the lower the permeability. Thus, PVC has a much lower permeability than LDPE. The permeability also increases with temperature — about 30 to 50% for every 5°C rise. Polymer formulations add to the complexity of the chemical mass transfer process because of the numerous combinations of polymer blends, copolymers, fillers, stabilisers and plasticisers (softeners).

Rubber materials also vary greatly depending on the source of natural latex used to make the rubber, or the chemical composition of the synthetic rubber (e.g. styrene butadiene rubber, SBR). Each plastic formulation (polymer material plus additives) has a characteristic void space that controls the rate of migration of gases and vapours — termed permeability or diffusivity, which is also a function of the size of the molecule permeating through the plastic. Fig. 6 shows the relationship between molecular volume (size) and diffusion rate through two plastics with dissimilar pore structures (Mark and Kroschwitz, 1985). The diffusion coefficient for natural rubber is about  $10^9$  (1 billion) times greater than that of PVC, for a molecule of the size of TNT. The molecular volumes of TNT, DNT and DNB are similar, producing similar differences

in the permeability of PVC and natural rubber. This is a key property that requires special notice. Mines made with rubber surfaces will permeate much, much larger amounts than PVC or other more dense plastics.

Figure 6  
Diffusion coefficients for chemical penetrants in rubber and rigid PVC

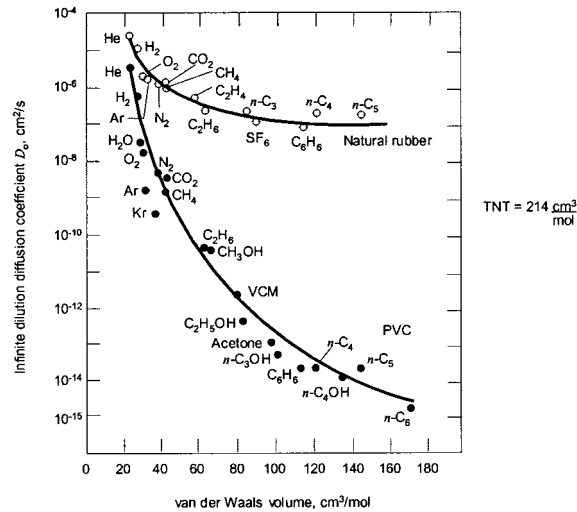

From: Mark and Kroschwitz (1985).

A metal mine (e.g. TMM1) is made from steel that has such a low permeability to landmine explosive vapours like TNT that permeation can be considered nil. This does not mean that metal mines do not leak, because there may be other pathways through poor construction seams or intentional openings, although threaded fittings would not be a likely leakage path as they typically create a very good vapour seal. However, metal mines may contain a short-term vapour signature from the paint. The paint is a polymer, which can be a reservoir for explosive chemical signatures that are derived from external sources, such as from storage in locations containing other explosive vapour sources (Bender *et al.*, 1992).

With such a large number of factors contributing to landmine leakage, it may seem that mine specific leakage tests would be needed to accurately describe this process. However, this would be an enormous task, so we must be satisfied with a few mine-specific test results and use polymer coupon tests to make estimates for the others.

### External surface contamination

One measure of the type and amount of explosive signature chemicals that leak from landmines is with an evaluation of the external surface contamination. This method measures the amount that is readily removable with a paper filter soaked in methanol. The chemical surface residue from the landmine is transferred to the paper filter, which is then analysed quantitatively. These surface residues are derived from both chemical permeation through the plastic from the inside of the landmine and from chemical vapour deposition on the outside during handling and storage. Also, this represents an amount that is currently on the surface, without replenishment, and not a continuous leakage rate that is important for evaluating the likelihood of detection in the future.

Measurements of the surface concentration of two TMM1 metal cased mines prior to burial showed levels of TNT at 10 and 62 ng/cm<sup>2</sup> and DNT at 10 and 20 ng/cm<sup>2</sup> (Jenkins *et al.*, 2000). After burial for 472 days, only a trace of TNT (0.4 ng/cm<sup>2</sup>) was found on just one of the mines demonstrating that the paint reservoir had been nearly depleted of landmine signature chemicals. Measurements on the concentration of explosive signature compounds in paint scraped from unused U.S. 60 and 81 mm mortars, and a 105 mm artillery projectile showed TNT and DNT levels that ranged from 1 to 45 mg/g — a considerable amount (Phelan *et al.*, 2001).

A small set of Yugoslav landmines acquired for emplacement at the Fort Leonard Wood, U.S., mine test facility were sampled before placement in the soil (Leggett *et al.*, 2000). These landmines had been in storage since production 40-50 years prior and included: PMA1A, PMA2, TMA5 and TMM1. The results from this effort showed that TNT, DNT and DNB were found on each mine type, and RDX was found on the PMA-2, which uses an RDX booster. The levels varied considerably, but ranged from <2 ng/cm<sup>2</sup> (the method detection limit) up to near 400 ng/cm<sup>2</sup>; however most were lower than 30 ng/cm<sup>2</sup>. These results are very similar to the mean value for both foreign and U.S. landmines at 15 ng/cm<sup>2</sup>, for tests using slightly different sampling and analysis methods (Hogan *et al.*, 1992). Surface residues found on Soviet TM62-P anti-tank landmines contained 6 ng/cm<sup>2</sup> TNT and 28 ng/cm<sup>2</sup> DNT for a bakelite case; and, 3 ng/cm<sup>2</sup> TNT and 5 ng/cm<sup>2</sup> DNT for a polyethylene case (Chambers *et al.*, 1998). Unfortunately, DNB was not quantified in this set of chemical analyses. The surface contamination confirms that the three signature chemicals, TNT, DNT and DNB are found on the outside of landmines, demonstrating that these compounds remain available as cues for detection by dogs.

### *Polymer coupon permeability*

To evaluate the permeability differences of the plastics used in landmines, small pieces of a landmine plastic (e.g. polymer coupon) were allowed to absorb military grade TNT vapours (containing all of the chemicals described previously) in a glass bell jar for about six months (Leggett and Cragin, 2002). The polymer coupons were then placed into tedlar bags (a very low permeability plastic) and allowed to exude chemical vapours for a set time period. The chemical vapours then deposit onto the interior tedlar bag surface. By washing the bag interior with a solvent and measuring the amount of chemical by quantitative analysis, a value that represents the release of vapours from the polymer coupon was determined. Other samples of these polymer coupons were placed into beakers of water, and also after a set time, samples of the water were obtained and analysed for the signature chemicals. Fig. 7 shows the results of these tests and demonstrate the effect of polymer type on release of chemical vapours. The flux of rubber is much, much greater than other polymers. Among the polymers, the higher density polymers (i.e. PVC) show a much reduced flux compared to low density polymers.

This work also indicated that the flux was greater into water than into air. Leggett *et al.* (2001) explains that with leakage into air, the explosive compounds are externally constrained by the limited vapour concentration in air. However, in water, the explosive compounds have a much greater solubility and mass transport is controlled by factors intrinsic to the polymer. Note that the differences in flux between water and air grows dramatically as the permeation rate of the polymer increases.

Figure 7  
TNT leakage rate dependence into air or water

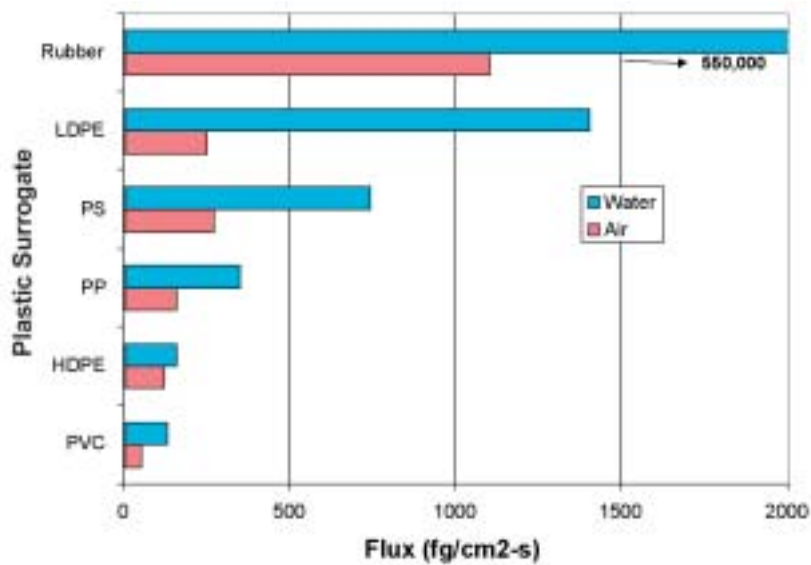

From: Leggett *et al.* (2001).

Figure 8  
Resident concentration of TNT in various plastics and landmine case materials

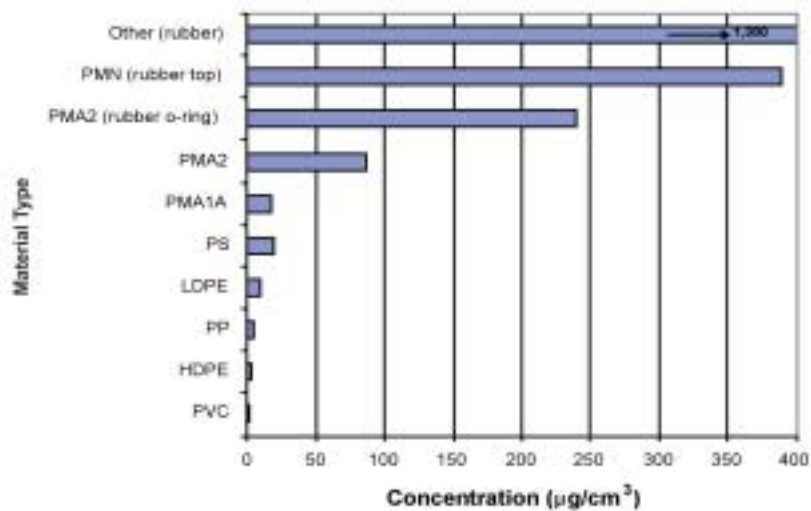

From: Leggett and Cragin (2002).

### TNT solubility in plastics

As noted earlier, the solubility of a chemical in a polymer contributes to the permeation rate. Leggett, Cragin *et al.* (2002) obtained small samples of the polymer coupons, dissolved them in a chemical (solvent), and measured the amount of TNT. Fig. 8 shows the results of these tests and indicates that lower density polymers contain a much greater resident concentration. These data also compare landmine specific materials with polymer coupons obtained from a commercial plastics supplier. A PMA2 is made from a polystyrene polymer, yet shows a slightly greater resident concentration than



from a U.S. commercial product. The PMA1A case is made from PVC and has a slightly greater TNT load than PVC from a commercial supplier. It is not known whether these differences are significant or not, or represent that the PMA1A and PMA2 have had 40-50 years to accumulate compared to six months for the commercial polymer coupons. However, Fig. 7 and 8 confirm that TNT (and speculatively for DNT and DNB) has greater permeation and solubility in low density polymers and rubbers than higher density materials.

### Landmine flux tests

In a similar set of experiments, five TNT-filled and one RDX-filled landmines were placed into tedlar bags for 2 to 7 days at temperatures from  $-3$  to  $34^{\circ}\text{C}$  (Leggett *et al.*, 2001). These tests found that the flux of the three principle chemicals (TNT, DNT and DNB) in the TNT mines were significantly different depending on the mine type and chemical (Table 10). The TMA5 had large fluxes most likely due to the holes on the bottom of the mine and the large surface area of this antitank mine. This will be found as soil residues underneath the mine, which may be more difficult to transport upward to the soil surface due to the presence of the mine itself. The PPM2 had the next highest flux. While the TMM1 mine appeared in this test to have a moderate flux of DNT, the chemical flux might diminish with time because of the limited reservoir of chemicals in the paint covering this metal mine. The PMA1A is a hinged box mine and it would be expected to have a much greater flux as the vapours can easily move out of the mine case. The PMA2 was shown to have the least flux due to the small size and low permeability of the PS case material.

| Mine  | Construction | TNT   | DNT    | DNB   | RDX |
|-------|--------------|-------|--------|-------|-----|
| TMA5  | PS           | 1,380 | 15,100 | 4,500 |     |
| PPM2  | unknown      | 128   | 12,800 | 3,480 |     |
| TMM1  | Metal        | 740   | 1,720  | 282   |     |
| PMA1A | PVC          | 207   | 1,550  | 358   |     |
| PMA2  | PS           | 24    | 282    | 332   |     |
| VS-50 | unknown      |       |        |       | 14  |

From: Leggett *et al.* (2001).

This work also showed the temperature dependence of the flux into air was exponential, similar to the temperature dependence of vapour pressure. The data showed that regardless of the mine type or material of construction, the exponent remained the same at 0.11 [ $y = a \times e^{0.11x}$ , where  $x$  is temp ( $^{\circ}\text{C}$ )]. Thus, for a  $5^{\circ}\text{C}$  change the flux changes by 1.7 times, for a  $10^{\circ}\text{C}$  change the flux changes 3 times, and for a  $20^{\circ}\text{C}$  change the flux changes 9 times.

When these mines were placed into water, the results showed a fast early time rise in solute concentrations followed by a steady increase with time. This initial rise is likely due to surface contamination dissolving into the water, followed by a steady permeation rate through the case materials. The flux values into water also followed that of the polymer coupon tests, showing a greater flux into water than into air (Table 11).

**Table 11**  
Comparison of mine flux into air and water at 22°C (ng/mine per day)

| Mine type | Medium | TNT   | DNT   | DNB   | RDX   |
|-----------|--------|-------|-------|-------|-------|
| PMA-2     | air    | 21    | 240   | 240   |       |
|           | water  | 1,270 | 720   | 1,300 |       |
| PPM2      | air    | 2,040 | 2,110 | 460   |       |
|           | water  | 4,640 | 6,690 | 1,000 |       |
| VS-50     | air    |       |       |       | 8     |
|           | water  |       |       |       | 1,460 |

From: Leggett *et al.* (2001).

Leggett *et al.* (2001) also report preliminary test data that landmines placed into dry sand showed greater flux than into wet sand. Upon first inspection, this appears to confound the results above. However, if the sand was not sterilised, a wet soil has a much greater degradation rate, which might appear as a lower flux (see Section 6: *Chemical degradation in soils*). More work is needed to resolve this discrepancy.

In work to evaluate the landmine flux into soil, Sandia National Laboratories created mine flux chambers from stainless steel and placed whole landmines into dry Sandia loam soil. Fig. 9 shows the test apparatus with a PMN and a PMA-2 landmine. The landmines were allowed to leak into the soil for 12 to 33 days, then the entire mass of soil was extracted with acetonitrile (1:1) with ultrasonication (18 hours at 10°C) and the TNT, DNT and DNB measured by GC/ECD. Table 12 summarizes these flux test results. A comparison of these values to the polymer coupon tests was completed by assuming that only the top rubber surface of the PMN mine contributes to the soil residue (~ 80 cm<sup>2</sup>), which corresponds to a TNT flux of 14,500 fg/cm<sup>2</sup>-sec, which is similar to the rubber into air value of ~1000 fg/cm<sup>2</sup>-sec (Figure 7). Completing the same comparison using the entire surface area of the PMA-2, the TNT flux is only 3 fg/cm<sup>2</sup>-sec, which is much less than the polystyrene (PS)[300 to 750 fg/cm<sup>2</sup>-sec] and closer to the PVC [50 to 100 fg/cm<sup>2</sup>-sec]. However, when one compares the PMA-2 results for TNT here (30 ng/day, Table 12) to that of Leggett above (21 ng/day, Table 11), the results are very similar.

Figure 9  
Whole landmine flux tests in soil



| Analyte          | PMN       | PMA-2 |
|------------------|-----------|-------|
| TNT              | 100 – 130 | 0.03  |
| DNT              | 35 – 50   | 1     |
| DNB              | 30 - 40   | 1     |
| Soak time (days) | 12 and 21 | 33    |

In earlier work, Spangler (1975) placed landmines in vapour collection chambers and measured the concentration increase over time. The methods included removing the main explosive charge, washing the casing to ensure that the mines were free of explosive materials, then loading the inner well with a foil coated with acetone recrystallized TNT to insure no external contamination was present prior to initiating the experiments. The TNT flux rates averaged over the surface area of the mines were  $10^{-16}$  to  $10^{-18}$  g/cm<sup>2</sup>-s. These values are equivalent to 0.1 to 0.001 fg/cm<sup>2</sup>-sec, which are much smaller than those found in the polymer coupon tests above. The low flux values determined by Spangler (1975) were likely a result of the preparation effort where the mine surface was cleaned and the small surrogate source inside contributed less mass for diffusion into the polymer.

An important but yet unresolved issue is how much soil wetness impacts chemical permeation by changes in the diffusion gradient. One feature of dry soils is that chemical sorption is much greater, depressing the vapour concentration in the soil (Section 5). Just like a temperature increase causes a greater gradient, depressing the vapour concentration in the soils also causes a greater gradient. Schematically, this is shown in Figure 10. As landmines are placed in surface soils that undergo periodic wetting and drying, the flux rate from landmines may vary depending on soil wetness, which requires quantification for use in simulation modeling tools (Section 9).

Figure 10  
Diffusive flux in dry or wet soil

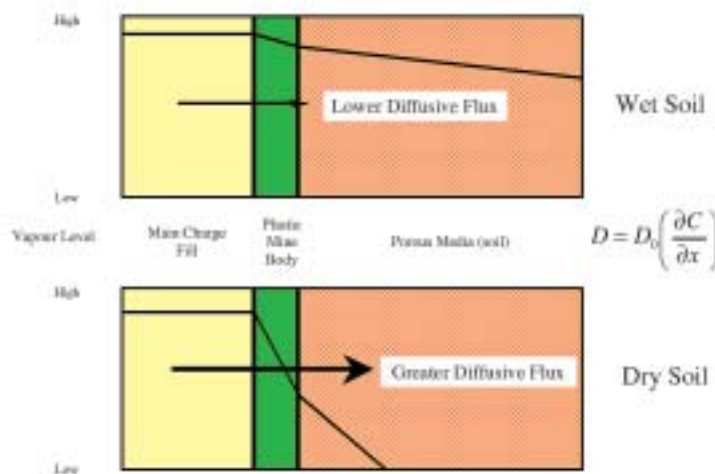

Completion of this effort is complicated by the requirement to sterilize the soil before a wet soil flux test is initiated. Wet soil (except frozen) provides a microbiologically friendly environment. Most (if not all) soils contain microbes that become active when

the soil becomes wet. In initial efforts to sterilise soils with radiation and chemicals, continued (yet reduced) TNT and DNT loss in soil slurry degradation tests demonstrated the difficulty in sterilising soils.

### Summary

The results from landmine specific flux tests are critical to the understanding of which mine type contributes more or less chemical to the soil. This mine flux (or source term) is directly proportional to the amount of chemical made available to the ground surface as a cue for the dog (see Section 7: *Chemical transport in soils*). Much more work is needed to evaluate the chemical flux into soil specific to each landmine type and the effect of soil wetness on landmine flux.

## 5. Chemical distribution in soils

In previous sections, the three principal chemical signature compounds from military grade TNT (TNT, DNT and DNB) have been measured in the main charge explosive, in the vapour above the solid phase explosive, and in the air and water from mine leakage tests. Once these chemicals escape from the landmine into the soil, soil physical processes cause significant effects that dominate the amount of the chemical cue available for trace chemical detection.

### Key information

- Landmine signature chemicals partition in the air, water and soil particles. Soil science can quantify these amounts and determine the concentrations in each.
- Soils with greater amounts of organic matter (agricultural or forest soils) or minerals (compared to desert sand) will sorb greater landmine signature chemicals, leaving less available for transfer to the air for vapour sensing.
- Soil moisture has a tremendous effect on soil-vapour sorption. Dry soils will sorb about 10,000 times more landmine signature chemicals than damp soils. This depresses the vapour levels the same amount. This process is reversible, so daily morning dew is valuable for vapour sensing, and afternoon drying is detrimental for vapour sensing.
- In damp soils, about 80 to 90% of the mass of TNT and DNT is found sorbed to the soil particles, about 10 to 20% is found in the soil water, and only 10<sup>-6</sup>% is found in the vapour.
- The soil acts as a temporary storage reservoir for the landmine signature chemicals, releasing them when dew or rain falls, and collecting more as soil water evaporates.

### Background

Soils are a complex medium that contains air, water and soil particles. The landmine chemicals can exist in the air as a vapour, in the water as a solute and on soil particles as a residue. Fortunately, through many years of agricultural and industrial chemical research, the science of soil physics has provided quantitative means to describe how much of a chemical resides in the air, water and on soil particles in a soil system (Jury *et al.*, 1990). This is extremely valuable because the environment (soil type, temperature, rainfall, wind, sunlight intensity, etc.) changes due to geographic location and with

local daily and seasonal weather cycles. In this section, information is presented on the steady state or equilibrium chemical phase partitioning processes. In Section 9, *Landmine-soil-weather systems analysis*, the complexity of time-dependent weather cycles is combined with soil physics to provide a comprehensive systems analysis tool.

In the previous sections, three chemical compounds were observed to be the most likely cues used by dogs (TNT, DNT and DNB). As work was underway to measure the factors important for the distribution of chemicals in soils, information became available that DNB was infrequently found in soil samples obtained adjacent to landmines (Section 10: *Soil residues from landmines*). Therefore, the work performed for chemical distribution in soils focused on TNT and DNT. If DNB becomes more prevalent in other landmine test programmes, then methods described in this section can be employed to determine needed values for DNB.

### Air and water solubility

There is a limit to the amount of chemical that can dissolve into air and water and sorb onto soils. The amount of chemical that dissolves into air is termed vapour pressure or vapour density, and is affected strongly by temperature. Fig. 11 shows the vapour density of TNT and DNT (Pella, 1977) and reveals that DNT is always greater than TNT by about a factor of twenty (20) and that both increase about four-fold for every 10°C temperature rise. The amount of chemical that dissolves into water is termed water solubility, and is also affected by temperature (but not as much as for vapour). Fig. 12 shows the water solubility of TNT and DNT (Phelan and Barnett, 2001) and reveals that DNT is also greater than TNT by about one and a half (1.5) and that each increases slowly up to 20°C, then increases much faster.

Figure 11  
Vapour density vs. temperature

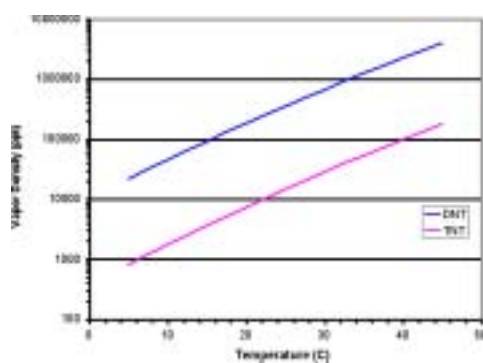
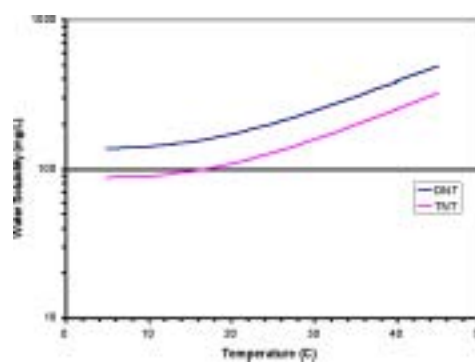

Figure 12  
Water solubility vs. temperature



### Air-water partitioning

In moist to wet soils, the pore space is filled partially with air and water. A measure of the amount of the chemical that exists in the gas phase to that in the aqueous phase, at equilibrium, is termed Henry's Law constant and is defined as

$$K_H = \frac{C_G}{C_L} \quad [1]$$

where  $K_H$  is the Henry's Law constant (unitless),  $C_G$  is the concentration in gas phase ( $\text{g}/\text{cm}^3$  headspace) and  $C_L$  is the concentration in the liquid (aqueous or water) phase

(g/cm<sup>3</sup> water). Henry's Law constant is also a function of temperature because both  $C_G$  and  $C_L$  are functions of temperature. A relationship for  $K_H$  as a function of temperature was developed with the relationships in Fig. 11 and 12, and is graphically shown in Figure 13. This reveals that  $K_H$  for DNT is always greater than TNT by about a factor of twelve (12) and increases by about 2.5 for every 10°C rise in temperature.

Figure 13  
DNT and TNT Henry's Law constant as a  
function of temperature

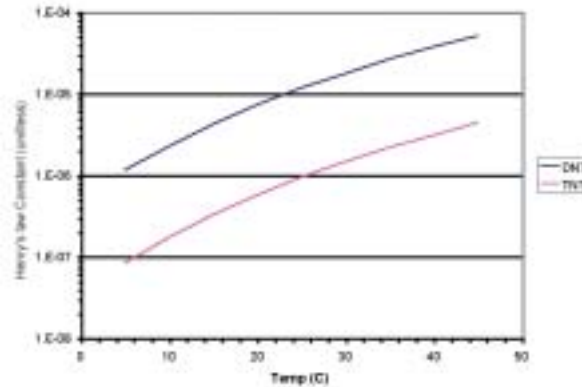

### Soil-water partitioning

The amount of chemical that is taken up or held (sorbed) by soils is a complex topic, with much research that has analysed the nature of the process and described which soil components (organic material, mineral phases) control the sorption processes (EPA, 1999). As with air/water partitioning, a measure of the amount of chemical in the water compared to the soil is used and is expressed as:

$$K_d = \frac{C_s}{C_L} \quad [2]$$

where  $C_s$  is the sorbed concentration (mg/g),  $C_L$  is the aqueous phase concentration (mg/mL), and  $K_d$  has units of mL/g.

Past research efforts that have measured aspects of soil-water partitioning for TNT have shown large differences depending on soil type. Pennington and Patrick (1990) report that TNT sorption has a higher correlation to cation exchange capacity than the fraction of organic carbon, though Tucker *et al.* (1985) indicated the variation in  $K_d$  was correlated to both organic carbon (64%) and cation exchange capacity (78%). The desorption of chemicals from soils may not always be complete due to some permanent retention or degradation (biological or abiotic). Pennington and Patrick (1990) found with three sequential desorption steps that 88 to 93% of adsorbed TNT was desorbed. However, Comfort *et al.* (1995) found near permanent retention of TNT. In measurements of 14 different soil types from Army Ammunition Plants across the U.S., the magnitude of the linear adsorption coefficients ( $K_d$ ) ranged from 2.3 to 6.8 mL/g (mean of 4.0) (Pennington and Patrick, 1990). These values provide a good estimate of the range of  $K_d$  values for typical soils.

To better understand desorption, Xue *et al.* (1995) performed equilibrium and kinetic sorption studies for TNT and RDX. With a bentonite clay/sand mix, no sorption



hysteresis was found indicating a fully reversible sorption mechanism. However, when two soils were used, the fully reversible adsorption-desorption behaviour was not found and little of the adsorbed TNT was released. Using actual aged contaminated soils from the Louisiana Army Ammunition Plant, about 50% of the TNT in the soil samples was unextractable. This effort quantified the linear adsorption coefficient ( $K_d$ ) for TNT at 2.7 and 3.6 mL/g, and for RDX at 1.6 mL/g for two soil types.

Very little work has been completed to measure the sorption of DNT on soils. Phelan and Barnett (2001a) used Southwestern desert loam soil (Albuquerque, New Mexico) and found the  $K_d$  to be 1.8 mL/g for low DNT concentration solutions and 0.7 mL/g for the high concentration solutions. The decline in the  $K_d$  value implies that the sorption isotherm is not linear and more likely follows a Langmuir or Freundlich model than a linear one. These data are comparable to those measured for a Midwestern soil located at Fort Leonard Wood (Pennington *et al.*, 1999) where the mean (std dev)  $K_d$  was 2.9 (1.4) mL/g.

Traditional standard methods to measure  $K_d$  are in batch equilibrium systems with a soil:water ratio of 1:4. This is convenient for testing, as the loss of analyte from the starting aqueous solution after contacting the soil for a standard time period (e.g. 24 hours) is assumed to be the amount transferred to the soil (EPA, 1989). The  $K_d$  value is determined as a linear fit of data based on variable starting solute concentrations. However, in unsaturated soils there are several factors that indicate that  $K_d$  values may vary as a function of soil saturation, causing potential increases and/or decreases in the  $K_d$  value.

With the pore space only partially filled with water, unsaturated soils have a smaller percentage of the total exchange sites in contact with the solute, which implies a potential decrease in the  $K_d$  value. Conversely, the water in unsaturated soil pores is closer to the soil particle surfaces, which implies a potential increase in the  $K_d$  value. Lastly, the ionic strength of unsaturated soil water increases due to the clay particle makeup of the small pores, which implies a potential increase in the  $K_d$  value (EPA, 1999). As these factors imply both a potential increase and a potential decrease in the value of  $K_d$ , and without knowing which factor has the greatest impact, more research is needed with measurements for specific chemicals and soil types. One effort reported that soil-water partition coefficients were overestimated using batch equilibrium measurement methods (Burglsser *et al.*, 1993) as a result of the particle concentration effect (solid-to-solution ratio and increased sorption capacity caused by particle separation during soil preparation).

In experiments with 2,4-DNT in a soil column breakthrough test, the  $K_d$  value was an important variable needed to improve data model comparisons (See Section 9). Batch equilibrium  $K_d$  measurements showed a linear  $K_d$  of about 1.7 mL/g; however, a much lower value of about 0.5 mL/g in a simulation model (T2TNT) improved the data model comparisons (Phelan *et al.*, 2000). Also, in unsaturated soil vapour partitioning tests, parameter estimation results improved significantly if  $K_d$  was included as a fitting parameter (Phelan and Barnett, 2001a). This work also showed that an unsaturated  $K_d$  value of 0.5 mL/g provided a better parameter fit. As most soils are frequently in an unsaturated condition, more work is needed to define the soil-water partitioning coefficient as a function of soil saturation.

The importance of the soil-water partitioning coefficient will become evident later in the discussion of the interactions of these phase partitioning processes. Nevertheless,

the data imply that TNT is sorbed slightly stronger to soils than DNT, the magnitude of the sorption is in the moderate range, and that in some soils there appears to be higher permanent retention (little is desorbed).

### Soil-air partitioning

The amount of chemical that is held by soils has been shown to be strongly impacted by the soil moisture content (Ong and Lion, 1991a and 1991b; Petersen *et al.*, 1994, 1995 and 1996; Ong *et al.*, 1992). This appears to be a competitive displacement process where soils have a tremendous sorption capacity for organic chemicals when dry, but when wet, water is preferentially sorbed to the soil particle, displacing the chemical. The soil-air partitioning process is described in a similar way as with air-water and soil-water, with

$$K_d(w) = \frac{C_s}{C_G} \quad [3]$$

where  $C_s$  is the soil concentration (g/g),  $C_G$  is the vapour concentration (g/mL),  $w$  is the gravimetric moisture content (g/g), and  $K_d(w)$  has units of mL/g (same as for the soil-water partitioning coefficient,  $K_d$ ). Fig. 14 shows the impact of soil moisture content in the dry range of 1 to 11% on the soil-air partitioning coefficient ( $K_d$ ). This figure shows the  $K_d$  for TNT and DNT increase by about  $10^8$  as the soil dries. This is a tremendous change although the range of soil moisture contents is typical of those found during weather cycles.

Figure 14  
DNT and TNT soil-vapour partitioning coefficient versus soil moisture content

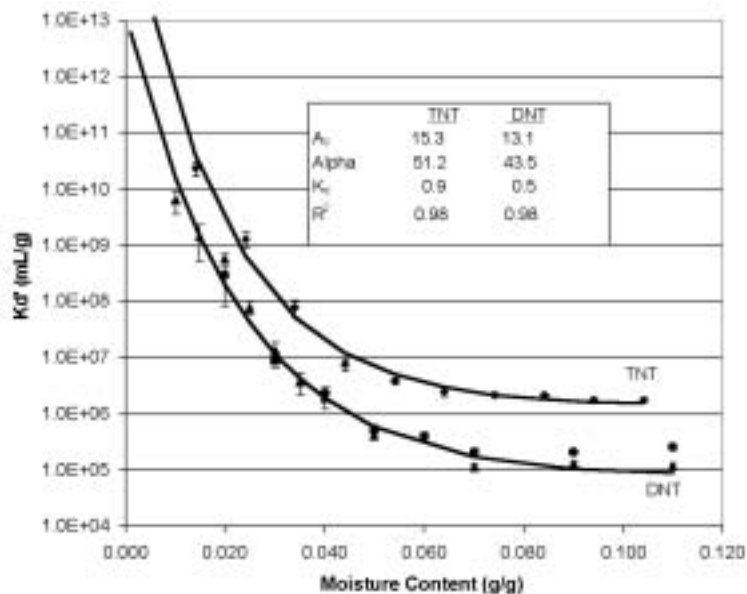

Source: Phelan and Barnet (2001a).

### Integrated soil chemical partitioning

The relationships described above can be assembled to show how chemicals partition between the air, water and soil sorbed phases. One can then evaluate shifts in these relationships due to changes in some of the key parameters. Jury *et al.* (1991) showed how the phase partitioning coefficients could be defined as phase mass fractions where  $f_s$  is the mass fraction sorbed to the soil,  $f_L$  is the mass fraction in the aqueous phase, and  $f_G$  is the mass fraction in the gas phase and, by definition,

$$f_s + f_L + f_G = 1 \quad [4]$$

Table 13 shows a simplified spreadsheet with integrated equations for the phase partitioning of TNT. A similar table has been prepared for DNT (not shown). With only basic information of temperature, soil moisture content (or soil saturation), soil-water partitioning coefficient, and the total soil residue, this spreadsheet can be used to evaluate impacts of varying these parameters on the mass fractions and the vapour concentrations in air available as a cue for the dog.

| Parameter                                | Input (I) or<br>or Output (O) | Value       | Units              |
|--|-------------------------------|-------------|--------------------|
| soil moisture (grav) – w                 | I                             | 0.15        | g/g                |
| soil temperature – T                     | I                             | 23          | °C                 |
| soil-water partition coeff – $K_d$       | I                             | 0.9         | mL/g               |
| Total Soil Concentration – $C_T$         | I                             | 1,000       | ng/g               |
| Total Solid Phase Concentration – $C_s$  | O                             | 0.86        | mg/cm <sup>3</sup> |
| Total Liquid Phase Concentration – $C_L$ | O                             | 0.94        | mg/L               |
| Total Vapour Phase Concentration – $C_G$ | O                             | 0.658       | ng/L               |
| Total Vapour Phase Concentration – $C_G$ | O                             | 70.347      | ppt                |
| Mass Fraction, Solid – $f_s$             | O                             | 0.86        |                    |
| Mass Fraction, Liquid – $f_L$            | O                             | 0.14        |                    |
| Mass Fraction, Gas – $f_G$               | O                             | 0.0000003   |                    |
| Mass Fraction, Total                     | O                             | 1.000000000 |                    |

Fig. 15 shows an example of the soil solid and liquid phase mass fraction of TNT and DNT using typical values shown in Table 13. At all soil saturations, DNT always has a greater liquid mass fraction and a lower sorbed mass fraction when compared to TNT. For both chemicals, the liquid phase mass fraction rises as more water is present in the soil pore space. When the saturation drops below about 8%, the impact of the soil-air partitioning process becomes evident. The liquid phase mass fraction becomes negligible with most of the mass fraction sorbed to the solid phase.

The effect of the soil-air partitioning process is more evident on the vapour mass fraction as shown in Fig. 16. Below about 10% saturation, the vapour mass fraction declines by a factor of about  $10^5$ . At high saturation, the vapour mass fraction also declines because the remaining air filled voids become filled with water.

To evaluate the effect of the soil-water partitioning coefficient ( $K_d$ ) on solid and liquid phase mass fraction,  $K_d$  was changed down to 0.5 mL/g and up to 3.0 mL/g as shown

in Fig. 17 for TNT. This range of  $K_d$  is likely typical for most soils; however, one can see that solid and liquid phase mass fraction is very sensitive to  $K_d$ . Fig. 18 shows the effect of  $K_d$  on the vapour mass fraction. As the vapour mass fraction is strongly controlled by  $K_H$ , which is affected by the liquid phase mass fraction, the effect of  $K_d$  on vapour phase mass fraction is approximately the same as for the liquid phase mass fraction in the range of 10 to 90 percent saturation. At the extremes, the effect of vapour-solid partitioning (low saturation) and diminished soil air porosity (high end) becomes prominent.

Figure 15  
Soil solid and liquid phase mass fractions

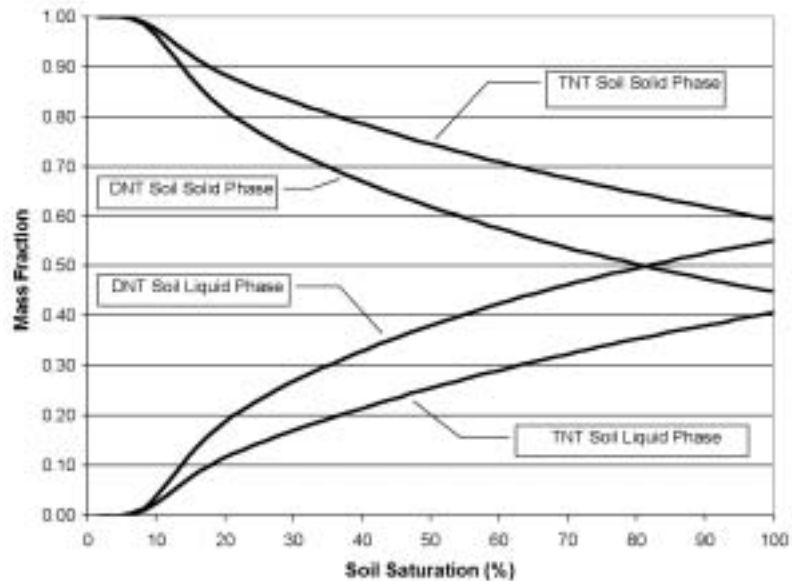

Figure 16  
Soil vapour mass fraction

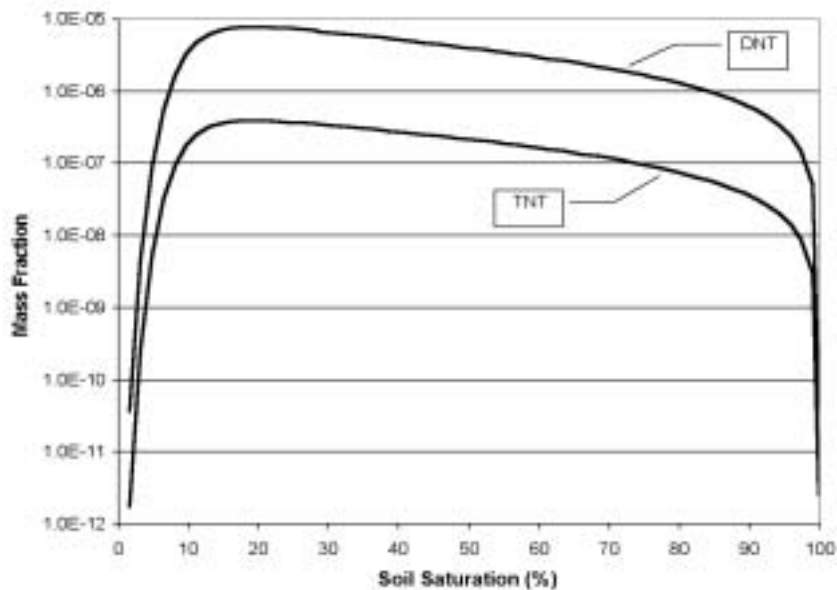

Figure 17  
Effect of  $K_d$  on TNT solid and liquid mass fraction

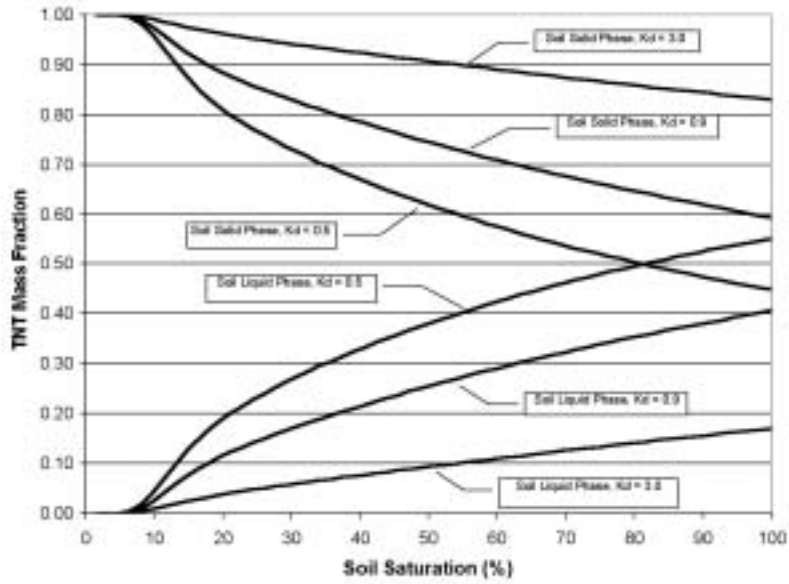
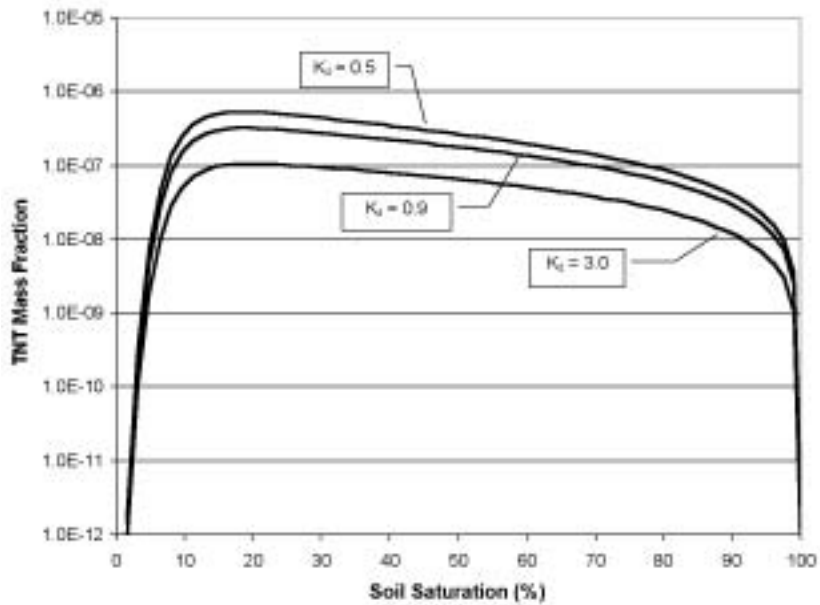
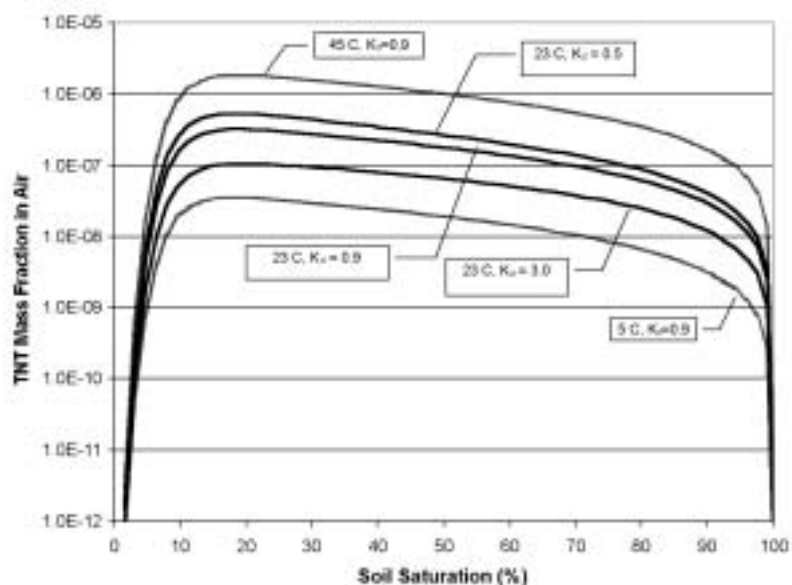

Figure 18  
Effect of  $K_d$  on vapour mass fraction



Temperature also has an effect because it affects both aqueous solubility and vapour pressure. Fig. 19 shows the effect of increasing the temperature from 23°C to 45°C ( $K_d = 0.9$  mL/g) and decreasing the temperature to 5°C ( $K_d = 0.9$  mL/g) for the TNT vapour mass fraction. Decreasing the temperature to 5°C has the effect of decreasing the vapour phase mass fraction by a factor of 10, while increasing the temperature to 45°C has the effect of increasing the vapour phase mass fraction by a factor of about 5.

Figure 19  
Effect of temperature on TNT vapour mass fraction



### Summary

After several decades of agricultural and industrial chemical research and field application, soil chemical interactions are generally understood. For landmine signature chemicals (i.e. TNT and DNT), laboratory test methods have defined the partitioning of these chemicals into soil systems. Soil phase partitioning relationships then define how much chemical is present sorbed to soil particles, dissolved in the water, and available in the headspace as vapour. The influence of temperature and soil moisture content can be accurately evaluated for any soil; however, the sensitivity of the soil-water partitioning coefficient demands that tests be completed for site-specific soils for improved accuracy. With these processes quantified, vapour concentrations can be derived (i.e. estimated) for use in mine dog vapour performance testing (Section 11) or from soil residues (Section 10) for comparison to mine dog vapour sensing thresholds.

## 6. Chemical degradation in soils

Degradation of explosive residues in soils is a very complex phenomenon, occurring through combined natural biological and abiotic processes. The biological reactions occur by either fortuitous reactions or, less frequently, through metabolic breakdown for microbial energy utilization (Spain, 1995). Abiotic processes are chemical reactions



with the soil components, typically iron bearing minerals that catalyse oxidation/reduction reactions (Hundal *et al.*, 1997).

The degradation process involves a series of reactions that alter the original structure of the parent compound, forming many by-products that may be transient (quickly transformed) or become permanently bound to the soil organic matter. Both biotic and abiotic processes require the presence of water to induce these transformation reactions. Without sufficient water, the landmine signature chemicals can remain in soils for long periods of time. Understanding the factors that promote or suppress degradation is critical, because the rate of loss directly impacts the vapours available as cues for trace chemical detection.

### Key information

- Landmine signature chemicals change form, chemical properties, and eventually become eliminated from soil systems by microbiological and soil mineral degradation reactions.
- The presence and amount of degradation by-products compared to parent compounds in soil samples is indicative of the degree of degradation that has occurred.
- Degradation by products may be valuable vapour cues for dogs; however, there has been limited investigation on this matter.
- Both biologic and abiotic reactions require water for degradation reactions to proceed.
- Laboratory measurements of TNT, DNT and DNB found degradation rates to be dependent on soil type, soil moisture content and temperature.
- Higher clay content and organic matter content soils have higher degradation rates.
- Soil moisture contents greater than 1% cause very fast degradation rates (half the amount degrades over the period of one day)
- Soil moisture contents less than 1% preserve landmine signature chemicals (half the amount degrades over the period of 3 years).
- Only subzero (°C) conditions limit degradation. The greater the temperature, the greater the degradation rate.

### Background

Both biological and abiotic chemical reactions produce similar degradation by-products due to the nature of the oxidation and reduction reactions. Table 14 indicates the principal degradation by-products for TNT, DNT and DNB. When found in soil samples, these compounds provide good evidence that degradation has occurred.

| Table 14<br>Parent and degradation by-products of TNT,<br>DNT and DNB |  |
|---|--|
| Parent compound   | Degradation by-product<br>(abbreviation)                                   |
| 2,4,6-TNT   | 4-amino-2,6-dinitrotoluene (4A-DNT)<br>2-amino-4,6-dinitrotoluene (2A-DNT) |
| 2,4-DNT   | 2-amino-4-nitrotoluene (2A-NT)<br>4-amino-2-nitrotoluene (4A-NT)           |
| 1,3-DNB   | 3-nitroaniline (3-NA)  |

Chemical degradation information is important when included with landmine chemical emissions (Section 4) and distribution in soils (Section 6) to understand the amount of chemical available as cues for trace chemical detection. As is becoming evident, the environmental impacts to landmine chemical cues are becoming very complex. In order to fully account for all of these processes, computer simulation tools become necessary (Section 9). Biochemical degradation losses are an important parameter that offsets the gain from landmine chemical emissions.

Degradation processes are typically modeled as a simple first order or pseudo-first order process (Sawyer *et al.*, 1994) that simplifies the simulation model input as a degradation rate constant, or half-life, that is independent of the chemical concentration. However, this simplification may lead to significant over or under estimates because the complex nature of explosive chemical degradation in soils is only beginning to be understood.

Very little information has been found on the intrinsic biodegradation rates of explosives in soils, because much of the literature reports data for active restoration methods such as composting or bioreactors where there is little correlation with natural conditions (Spain *et al.*, 2000). More recent work on natural attenuation processes is a closer analogy, although work has been limited to aquifer self cleansing and is not directly applicable to surface soils. However, reports from work on stability of analytes in soil samples, natural soil and post blast residue degradation studies have helped to define the nature of TNT, DNT and DNB degradation rates in soils.

### *Analyte stability studies*

Past work that evaluated the maximum holding times (time before chemical analysis begins) for soil samples contaminated with trace levels of nitroaromatic compounds is one source for degradation rates of TNT and DNT (Maskarinec *et al.*, 1991; Grant *et al.*, 1993). Analysis of these reports shows a significant impact of the soil residue preparation method (aqueous or solvent enriched, or field contaminated), soil type, temperature, and data analysis method. The data from Maskarinec *et al.* (1991) were not used in this evaluation as this test used an excess solvent enrichment method (2 mL acetonitrile/2 g soil), not representative of landmine released chemical signatures.

Grant *et al.* (1993) prepared soils with aqueous enrichment (solute in water) with varied amounts of water held at room (22°C), refrigerator (2°C) and freezer (-15°C) temperatures. In addition, field contaminated soil from an Army production plant was tested. Water was added up to the maximum holding capacity of the soils (no visible freestanding water) and the temperature was held constant at room (22°C), refrigerator (4°C), and freezer (-15°C) temperatures. The moisture content was 4% (weight/weight or w/w) for the sandy loam, 20% (w/w) for the silty loam and clay soils, and 25% (w/w) for the field-contaminated soil. The nitroaromatic enriched soils showed a dramatic decline in concentration with time for TNT and DNT at room and refrigerator temperatures in all three soils. Only at freezer temperatures was the degradation limited. The effect of soil type was dramatic as well, as the clay soil induced significantly more loss than either the sandy or silty loam. However, the field-contaminated soil, at nearly the same initial concentration as the enriched soils, showed a much reduced degradation rate.

Because the data were used to define maximum holding times, Grant *et al.* (1993) did not report degradation rate constants. However, these data were re-evaluated to

calculate degradation rates along with new data using soil from the Fort Leonard Wood minefield test site (Miyares and Jenkins, 2000). Miyares and Jenkins (2000) prepared the soil with sieving to retain < 0.42 mm, moistened the soil to 20% (w/w) for 3 days to allow microbiological activity to become established, then added TNT, 2,4-DNT, 2,6-DNT and DNB and RDX in an aqueous solution, which increased the soil moisture content to 40% (w/w). Samples were held at 22, 4 and -4°C for up to 20 days. At 22°C, the TNT data did not show true pseudo or actual first order decay rates. In fact, there was an initial fast decline in the first day followed by a more moderate decline. Using the initial fast decline, the half-life in the loam soils was estimated for TNT to be on the order of 1 day at 22°C. For the other chemicals and temperatures, the loss is properly described by a single first order process. Table 15 summarises the results from these efforts for TNT, DNT and DNB.

Table 15  
Degradation half-lives for wet soils

| Temp (°C) | Fort Leonard Wood (siltloam) | Silt | Sandy | Loam | Clay | Aquifer |
|-----------|------------------------------|------|-------|------|------|---------|
| TNT       | 22                           | 1    | 2     | 4    | < 1  | 140     |
|           | 2 or 4                       | 17   | 17    | 20   | 1    |         |
|           | -4                           | 80   |       |      |      |         |
| 2,4-DNT   | -15                          |      | 520   | 5300 | 170  |         |
|           | 22                           | 26   | 50    | 53   | 2    |         |
|           | 2 or 4                       | 53   | 180   | 230  | 13   |         |
|           | -4                           | 86   |       |      |      |         |
| 1,3-DNB   | -15                          |      | 1100  | 1100 | 144  |         |
|           | 22                           | 10   |       |      |      |         |
|           | 2 or 4                       | 33   |       |      |      |         |
|           | -4                           | 84   |       |      |      |         |

Source: Miyares and Jenkins (2000).

### Natural attenuation studies

Cataldo *et al.* (1993) incorporated 60 mg/g (ppm) of TNT in three soil types (0.5%, 1.7% and 7.2% organic matter) and followed extractable, unextractable and parent compounds over 60 days. The parent TNT concentrations fell below 3% of the original concentrations within 10 days (equates to a half-life of 2 days). Extractable parent compound and transformation products showed an exponential decline reaching near steady state at 60 days. The unextractable fraction showed similar response, growing to about 40% at 60 days. In the high organic matter soil, permanent sorption reached a greater level (~50%) and the extractable/unextractable fractions reached near steady-state much faster (about 10 days). Chemical analysis of the extractable fraction found isomers of aminodinitrotoluene and a range of unidentified more polar compounds. The production of more polar compounds is typical of biotransformation processes that produce more water soluble compounds — which makes the transformation products less volatile and available for vapour phase collection, concentration and detection. Work with RDX showed that there was little transformation and most of the parent compound remained at 60 days.

### Post-blast residue degradation

In an evaluation of degradation rates of post-blast residue from detonated landmines, Phelan *et al.* (forthcoming) detonated a PMA1A landmine and collected the post blast

residue on long sheets of paper (30 m x 0.6 m). This material was combined, mixed well and split into 20 g aliquots (to help mitigate heterogeneity problems) for treatments at 5°, 24° and 40°C, and 1%, 5% and 10% (w/w) moisture content. To assess whether the nature of the post blast residue degradation was affected by other blast products (e.g. soot), a synthetic contaminated soil was prepared by solid phase enrichment methods at the same starting concentration of TNT found in the post blast residue (and also included DNT).

Results from this work showed that at soil moisture contents of 1% (w/w), the data were quite variable indicating that the combined post-blast residue was not uniform, although there was virtually no loss of TNT. However, with soil moisture at 5% and 10% (w/w), the degradation proceeded very quickly. The degradation kinetics were not first order, with a fast initial phase followed by a much slower long term decline, similar to that found by Miyares and Jenkins (2000).

In order to estimate the degradation half-life, the data was transformed ( $\ln C/C_0$ ), outlier data was removed, and the data were fitted with a linear equation. Where appropriate, only data from the first few days were used if there was an early time rapid decline followed by a slower rate. Table 16 reveals the results of this analysis and shows that a moisture content of 1 % (w/w) prevents significant degradation. At moisture contents of 5% and 10%, the degradation rates were very rapid. Unfortunately, this post-blast residue did not contain any measurable DNT or DNB to compare to the TNT.

| Soil moisture content (% w/w) | Temperature (°C) |     |     |
|-------------------------------|------------------|-----|-----|
|                               | 5                | 24  | 40  |
| 1                             | 1155             | 730 | 140 |
| 5                             | 16               | 1   | 1   |
| 10                            | 6                | 3   | 1   |

Source: Phelan *et al.* (forthcoming).

Table 17 shows the results from the synthetic soil degradation study. The experimental design did not evaluate all of the temperature and soil moisture combinations; however, these results are similar to those in Table 16 and demonstrate that the post-blast residue degradation may be representative of landmine released chemicals in soils. Fig. 20 shows a 3-D graphic of the impact of soil moisture content and temperature on the degradation half-life of TNT in post blast residue (Table 16).

| Soil moisture content (% w/w) | TNT Temperature (°C) |    |    | 2,4-DNT Temperature (°C) |    |    |
|-------------------------------|----------------------|----|----|--------------------------|----|----|
|                               | 5                    | 24 | 40 | 5                        | 24 | 40 |
| 1                             | 350                  |    |    | 700                      |    |    |
| 5                             | 1                    |    |    | 1                        |    |    |
| 10                            | 0.5                  |    |    | 0.5                      |    |    |

Source: Phelan *et al.* (forthcoming).

Figure 20  
3-D plot of post-blast residue degradation half-lives as a function of soil moisture and temperature

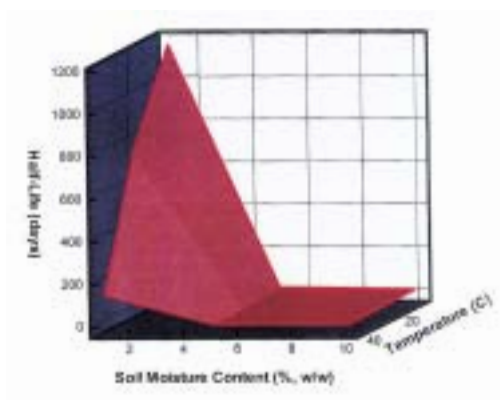

Source: Phelan *et al.* (forthcoming).

### Summary

These results confirm that degradation rates are quite variable with major influences from soil type, temperature and soil moisture content; and, simple first order degradation kinetics do not often properly describe the loss process. However, it is clearly evident that above 1% moisture content (air dried soil), the degradation rate is extremely fast. This has significant implications for field samples collected wet, as only frozen conditions truly limit the degradation rate. Developing a complete set of quantitative values for use in simulation model analysis would take much more effort; however, the results presented above can be used to qualitatively compare regionally dry climates (e.g Afghanistan) versus wetter regions (e.g. Bosnia and Herzegovina, and Cambodia).

## 7. Chemical transport in soils

Landmine signature chemical transport in soil is crucial to understanding the amount of vapour available as a cue to the dog. Landmine chemical leakage, soil chemical partitioning and chemical degradation all play a role in how much chemical is present, but the chemical must move (be transported) from the proximity of the landmine to the ground surface to become available as a cue.

In Section 5, we described how landmine signature chemicals can exist in three phases: as a solute, as a vapour and sorbed to soil. In most circumstances, only vapour and solutes move through soils. There are two principal processes that contribute to chemical transport in soils: diffusion and convection. Diffusion is motion driven by differences in concentration (high to low) between locations, scaled by the internal energy of a molecule (diffusivity), which is affected by interactions with the soil. Diffusion can occur with both vapours in air and solutes in water.

Convection is the act of transporting chemicals in a stream of air or water. During infiltration of rainfall, solutes in water are convected downward. Evaporation convects solutes upward. Movement of air in soils induced by wind and barometric pressure can also convect vapours downward into and upward out of surface soils.

### Key information

- Movement of landmine signature chemicals is controlled by chemical and soil properties, and driven mostly by the movement of water in soils.
- Water transports more TNT, DNT and DNB by convection than occurs by either vapour or solute diffusion.
- Conditions that cause upward evaporation of soil water in proximity to the landmine will be most beneficial for chemical sensing.

### Diffusion

Over the last 30 years, researchers have explored diffusion of chemicals in soil. Hamaker (1972) shows data where the diffusivity of a vapour in air decreases by a factor of three or more when the same vapour diffuses in a soil. Diffusion constants in soil are expected to be lower due to the tortuosity of the flow path, reduced flow area, and due to interactions with the soil (adsorption) and soil water (solution).

Early efforts developed an effective diffusion coefficient for soil as an aggregate parameter that included vapour and liquid phase diffusion, soil-vapour partitioning, and soil-water partitioning. Vapour pressure, water solubility and phase partitioning coefficients were integrated to provide an effective diffusion coefficient for a given soil. The most widely used function for soil diffusivity is an adjustment of the diffusivity of a vapour in air based on the volumetric air content and porosity using the tortuosity model of Millington and Quirk (1961). Jury *et al.* (1983) applied this same concept to the diffusivity of a solute in soil with the volumetric water content and porosity.

Combining the Millington and Quirk (1961) tortuosity model with phase partitioning functions, Jury *et al.* (1983) established an effective diffusion coefficient that describes whether diffusion is predominantly in the vapour or liquid phase, and the dependence on phase partitioning coefficients and soil moisture content (i.e. soil saturation). Fig. 21 shows the diffusivity of TNT in soil air, soil water and the sum of both — the effective diffusivity. This chart shows that solute diffusivity dominates vapour diffusivity at soil saturation values greater than about 20%. A soil saturation value of 20% is about 10% soil moisture by weight and is considered only damp. So, during periods of moderate soil wetness, diffusive transport of TNT transport occurs mostly through the soil pore water. During dry periods, vapour diffusivity dominates, but is reduced by a factor of 10 – 100.

Table 18  
Estimated chemical properties

|                              | 2,4,6-TNT | 2,4-DNT | 1,3-DNB |
|------------------------------|-----------|---------|---------|
| $K_H$ (25°C)                 | 5.9E-7    | 4.15E-6 | 9.6E-5  |
| $K_d$ ( $f_{oc} = 0.005$ )   | 2.5       | 1.2     | 0.17    |
| $D_i$ (cm <sup>2</sup> /day) | 0.580     | 0.632   | 0.686   |
| $D_g$ (cm <sup>2</sup> /day) | 5530.     | 5790.   | 6310.   |



Figure 21  
TNT vapour, solute and effective diffusivity

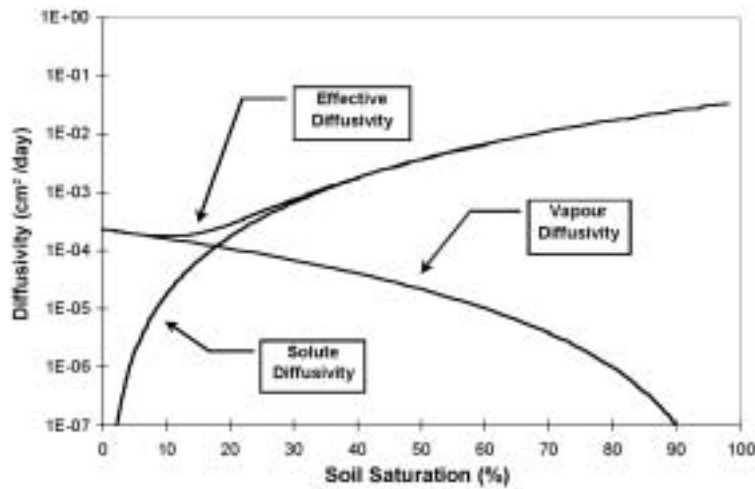

Source: Phelan and Webb (1997).

Fig. 21 is valid for soil saturation values greater than about 15% because, below this value, soil-vapour sorption becomes significantly greater (see Section 5). The effect of soil-vapour sorption on the effective diffusivity of TNT, DNT and DNB was explored by Webb *et al.*, 1999. Using the estimated chemical properties in Table 18 and vapour-solid partitioning values from Phelan and Barnett (2001a), Fig. 22 shows a dramatic decline in effective diffusivity below 15% saturation.

This means that in dry soils, transport of landmine signature chemicals is essentially halted. However, when sufficient rainfall occurs, the chemicals that have accumulated on the dry soils can begin to move through combined vapour and solute diffusion.

Figure 22  
Effective diffusivity for TNT, DNT and DNB with soil saturation

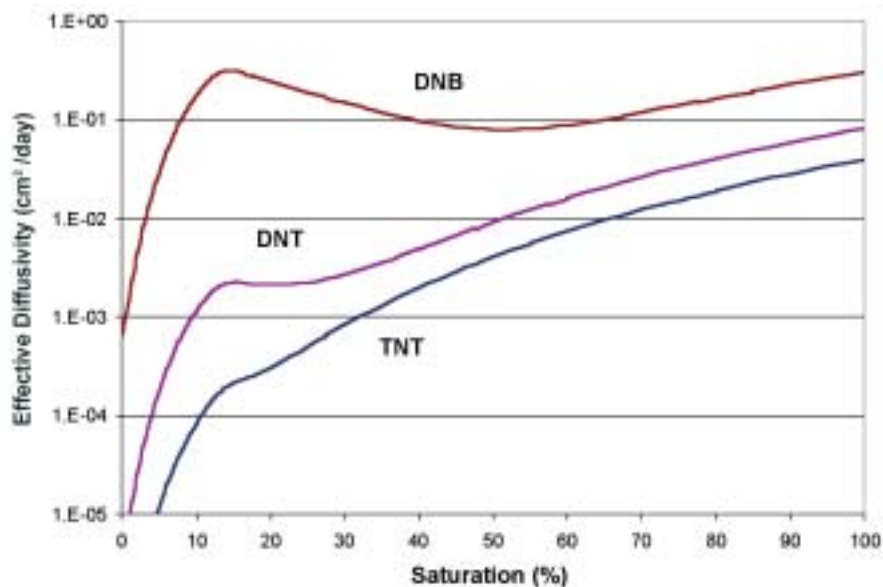

Fig. 22 shows some other very important differences between TNT, DNT and DNB. The effective diffusivity of TNT is much less than DNT, which is much less than DNB because of parallel trends in  $K_H$ ,  $K_d$ ,  $D_l$  and  $D_g$ . From Fig. 22, one can see that TNT is dominated by solute diffusion and is always less than DNT and DNB. For DNT, vapour diffusivity starts becoming dominant at soil saturation less than 25% and for DNB, becomes dominant at soil saturations less than 55%. From Table 18, vapour diffusivity values for TNT, DNT and DNB are all about 10,000 times greater than solute diffusivity — meaning vapour diffusion is always much greater than solute diffusion. This means that in damp soils, the effective diffusivity of DNB does not decline as with DNT and TNT and remains 10 to 100 times greater until soil-vapour sorption becomes important.

### Convection

Convection describes the transport of a solute in a flowing soil solution. Chemical convection is the product of the solute concentration and the flux of water. Landmine signature chemicals held in stagnant soil pores will mix with infiltrating rainfall and be convected downward. The chemicals bound to soil particles will desorb until the soil-water partitioning relationship is satisfied. After rainfall ceases, soil water can move upward, pulled by evaporation from the ground surface. As described in Section 5, the mass fractions of TNT, DNT, and DNB are always much, much greater in water than in air. Thus, the optimal transport conditions are when water is moving upward through soils.

### Vapour transport through soils

In an effort to determine the effects of soil barriers on the transport of vapours from military-grade TNT, Jenkins *et al.* (1999) performed laboratory experiments that measured headspace vapour concentrations over time as a function of soil type, soil moisture content, and temperature. These tests used crystalline TNT (110 mg) buried below 2.5 cm of soil in 40 mL (27 x 95 mm) vials. Vapour samples were obtained at intervals up to 173 days. When terminated, the top 1 mm surface soil was collected and analysed for residues of target analytes and soil-vapour partition coefficients were determined using the last vapour sample result.

Figure 23  
Vapour transport study results

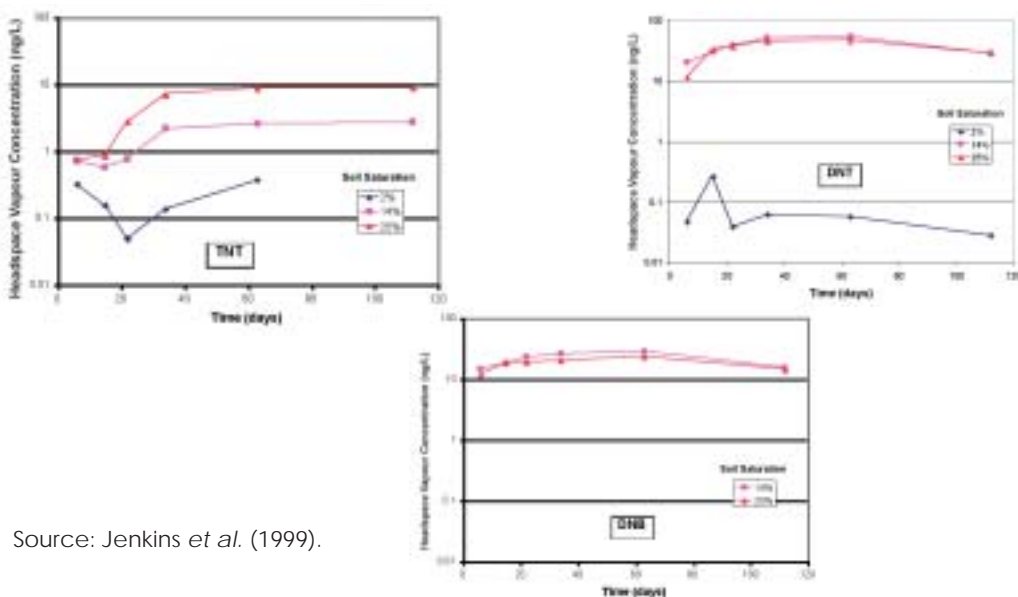

Source: Jenkins *et al.* (1999).

These tests mimic only vapour transport because the vials were capped, which limits water movement and transport mechanisms. Fig. 23 shows the results for TNT, DNT and DNB from one test series with silt soil at 23°C. For each chemical, the lowest soil moisture content (soil saturation) showed significantly reduced vapour concentrations (DNB vapour levels were below method detection limits) as a result of enhanced soil-vapour sorption. The increased vapour-solid sorption affects equilibrium partitioning between the surface soil residues and the headspace vapours (Fig. 14), and the effective diffusion coefficient (Fig. 22).

If one assumes that, at about day 60, the experiment has reached equilibrium where transport, repartitioning and degradation processes are all at steady-state, then one can qualitatively evaluate the magnitude of the headspace vapour concentration as an indicator of the magnitude of the effective diffusivity. From Fig. 22, the effective diffusivity of TNT continuously rises as a function of soil saturation — and so do the headspace vapour concentrations. However, the effective diffusivity of DNT rises from low saturation, but the values are similar at 14 and 25% saturation — and so are the headspace vapour concentrations. For DNB, the effective diffusivity declines from 14 to 25% saturation — and the headspace shows slightly lower headspace vapours at 25% compared to 14% saturation.

The work of Jenkins *et al.* (1999) demonstrates that vapour transport of landmine signature chemicals is affected by soil type, soil moisture content and temperature. They conclude that vapour concentrations were highest with sands, intermediate with silts and least with clays, consistent with a greater soil-water partitioning in the finer grained soil types. They conclude that dry soil conditions limit vapour transport, limiting headspace vapour concentrations to much lower levels than in moderately wet soils. Temperature was also important, where a change from 23°C to 4°C decreased vapour levels by a factor of at least 10, and at -12°C many of the headspace vapour samples showed non-detectable levels, more so in the clay and silt.

### Summary

Transport of landmine signature chemicals in soils is necessary to move the landmine odour from the buried location to the soil surface. The driving forces for this movement, diffusion and convection, have been well studied providing a good understanding and mathematical representation for simulation modeling efforts. As vapour and solute diffusion, and air and water convection, occur simultaneously in variable amounts depending on the weather and soil conditions, it is mostly academic to evaluate how much chemical is transported by each mechanism.

However, since much more landmine signature chemical is present as a solute in soil pore water compared to that present in soil air, the movements of soil pore water control the transport of the landmine odour. Thus, processes that influence the upward evaporation of water between the landmine and the ground surface are important factors that increase the surface soil trace chemical residues. In locations where rain is infrequent, and evaporation from soils is minimal, vapour diffusion may become more important, although the mass transport rates may be much reduced.

While a comparative analysis of mass transport by each mechanism may be academic, it would establish the magnitude for each process, and when one mechanism is absent (e.g. drought weather cycles), provide more understanding on the performance requirements for trace chemical detection.

## 8. Weather factors affecting chemical sensing

Chemicals released from landmines undergo transport and degradation processes in the soil as discussed in earlier sections. The chemical signature that reaches the soil surface is released into air currents near the surface, or the boundary layer, where it is rapidly diluted by the wind. The chemical signature above the boundary layer is essentially zero. This behaviour is schematically shown in Fig. 24. The chemical signature concentration is depicted by the concentration of red dots in the figure. Mine dogs sense the chemical concentration in the chemical boundary layer, and possibly on surface particles that are inhaled by the dog. The thickness of the chemical boundary layer is dramatically influenced by the weather conditions at the surface as is discussed in this section. In order to determine the best and worst times for chemical detection, the boundary layer behaviour as influenced by weather conditions needs to be understood.

Figure 24  
Depiction of chemical concentration variation including the boundary layer

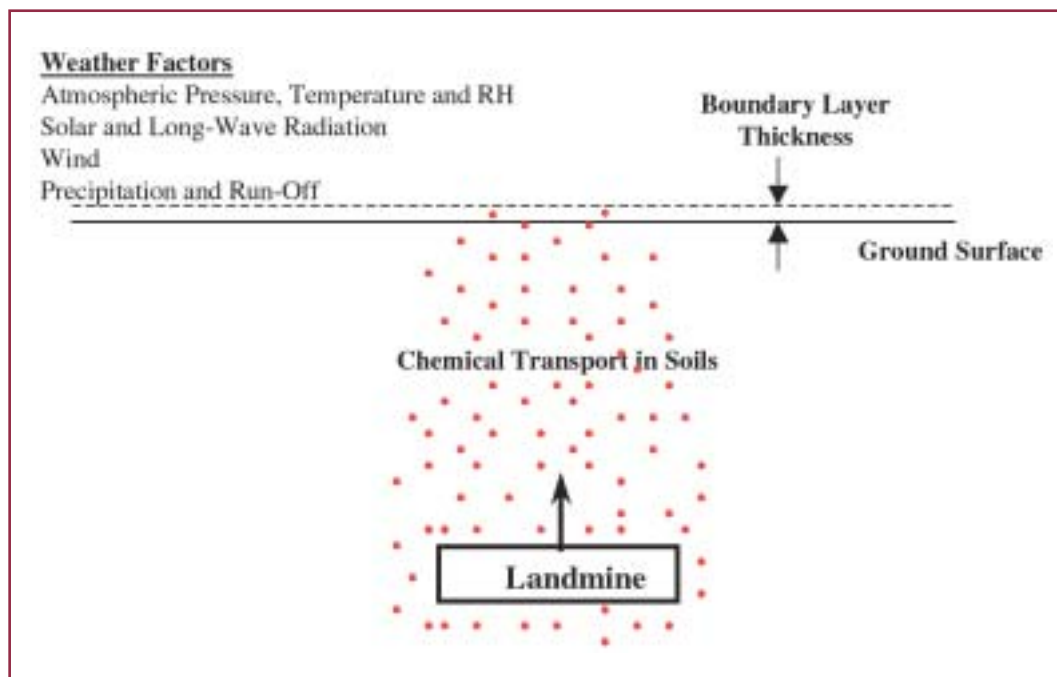

There has been a long history of research on the impacts of weather on near-surface soils for agricultural applications. The information needed to understand the heat and moisture balance for crop production and agricultural chemical (fertilizers and pesticides) efficacy can be used to understand the chemical transport in soils up to the ground surface. Some of the models developed for agricultural and chemical transport in the near-surface soils have been used for preliminary consideration of landmine chemical transport as discussed in Section 9, *Landmine-soil-weather systems analysis*.

In contrast, chemical transport in the air boundary layer above the soil surface has not been explored in detail. The boundary layer near the ground is driven by thermal processes and is a complicated interaction between thermal radiation gains and losses, evaporation of water, and the presence of low-growing plants (Geiger, 1957). Chemical

transport in the air boundary layer is coupled with chemical movement in the soil and will be influenced by the weather and, in the present situation, by the actions of the dog.

This section introduces the key weather factors that influence the chemical concentration near the surface and in the boundary layer. An alliance of micrometeorology (weather near the ground) and soil physics (chemical transport in soils) is necessary to fully understand the impacts to the landmine chemical signature and the availability of vapours for chemical sensing. Section 9: *Landmine-soil-weather systems analysis* begins to describe this alliance and presents tools to evaluate the complex interactions that weather induces on vapour concentrations at the soil surface. Much more work is needed to understand the impacts of weather on the chemical concentration in the boundary layer for the landmine scenario including the effect of dogs.

### Key information

- The factors that affect chemical movement and concentration from the ground surface into the layer of air closest to the ground (i.e. the soil-atmosphere boundary layer) have not been thoroughly evaluated.
- Differences between the temperature of the soil and the air make a significant impact on localised vertical air movement that either dilutes or traps the vapours emanating from the soil.
- Soil temperatures greater than air temperatures cause an unstable boundary layer with mini-thermals that dilute landmine signature chemical vapours — the greater the temperature difference, the greater the impact.
- Soil temperatures less than air temperatures cause mini-inversions that trap landmine signature chemical vapours in the boundary layer.
- Winds also impact the boundary layer — as the wind velocity increases, the boundary layer thickness decreases and the dilution increases.
- The influence of the dog's actions on the chemical boundary layer behaviour has not been extensively considered.

### Weather factors

The weather factors that will be considered include:

- atmospheric pressure,
- atmospheric temperature,
- atmospheric relative humidity (vapour pressure),
- solar radiation (short-wave),
- long-wave radiation,
- wind velocity,
- precipitation,
- plants.

While not a weather factor *per se*, the effect of plants is generally to mitigate the influence of the weather at the ground surface. Each weather factor will be discussed including the impact on the air boundary layer thickness. For purposes of this discussion, some of the factors will be lumped together. Atmospheric temperature, solar radiation, and long-wave radiation will all influence the soil surface temperature, which will be discussed in detail. The atmospheric relative humidity and precipitation determine

the direction of water vapour and liquid water mass flux, which will be discussed together.

### *Atmospheric pressure*

Atmospheric pressure variations generally have a minor influence on chemical vapour transport. As the pressure varies, such as when a weather system passes through, there will be a slight change in the convective transport of the chemical signature in the vapour phase out of the soil; this process is often referred to as barometric pumping (Auer *et al.*, 1996). The effect is generally small, however, compared to the other weather processes.

### *Soil surface temperature*

The soil surface temperature is directly influenced by the atmospheric temperature, solar radiation, and long-wave radiation. The higher the atmospheric temperature, the higher the soil surface temperature.

The thermal radiation energy balance at the soil surface has three components. *Solar* (short-wave) *radiation* from the sun adds energy to the soil surface. *Long-wave radiation* emitted from the atmosphere also adds energy to the soil. The soil loses energy through *long-wave radiation emittance* to space.

Radiation from the sun is absorbed and reflected in the atmosphere and is influenced by the altitude, clouds, water vapour, and the presence of particles such as smoke and dust in the atmosphere (Arya, 1988). Clouds, water vapour, and particles all decrease the net solar radiation reaching the soil surface, while a higher altitude increases the net solar radiation. Solar radiation is obviously highly variable during the day and is generally maximum in the early afternoon and zero at night. The net solar radiation reaching the soil surface is partially absorbed by the soil and partially reflected. The fraction of incoming radiation that is reflected back to the atmosphere is called the surface albedo, or reflectivity. The lower the albedo, the higher the net incoming radiation absorbed by the soil surface. Darker and wetter soils tend to have a smaller albedo than lighter and dryer soils (Campbell and Norman, 1998); therefore, more solar radiation is absorbed in darker and wetter soils.

The net long-wave radiation added to the soil surface is the long-wave radiation added from the atmosphere minus the long-wave radiation lost to space. Long-wave radiation from the atmosphere to the soil is affected by the presence of clouds, and water vapour as well as the air temperature in the atmosphere. Long-wave radiation flux from the atmosphere to the surface is slightly higher for clouds than with a clear sky and increases with increasing air temperature. The amount of long-wave radiation lost into space is dependent on the temperature of the surface. Both long-wave radiation components are directly dependent on the emissivity of the soil surface. Darker soils and wetter soils would have a slightly larger emissivities than lighter and dryer soils. A darker soil increases the net long-wave radiation value. Whether the net long-wave radiation is positive or negative depends on the relative temperatures of the atmosphere and the soil, as well as the emissivity of the clouds. Generally, however, the net long-wave radiation is negative.

The thermal radiation energy balance is generally positive during the day due to solar radiation and is negative at night due to the net long-wave radiation. However, there



are other processes that affect the heat balance of the soil surface. As mentioned earlier, heat is also added (or subtracted) to the soil surface due to the atmospheric temperature. Heat is also conducted to and from the surface by heat conduction through the subsoil. During the day, the soil surface temperature is generally higher than the soil underneath, so heat is conducted into the underlying soil. Similarly, at night, the soil surface temperature is less than the underlying soil, so heat is added to the soil surface through conduction. Mass transfer also influences the soil surface temperature. Water evaporation and condensation, e.g., dew, also become heat sinks (evaporation) and heat sources (condensation) at the surface.

As seen from the above discussion, the soil surface temperature is a complex energy balance including the effects of air temperature, radiation (solar, long-wave, and radiation to space), conduction in the soil, mass transport in the soil, and evaporation and condensation processes at the surface. The surface temperature of the soil affects the chemical signature at the surface. For example, at higher temperatures, the vapour-liquid partitioning coefficient, or Henry's coefficient, will be higher, meaning that more of the mass is in the gas phase. The local water vapour pressure will also be increased, possibly leading to higher evaporation rates, which will increase the chemical vapour flux rate into the boundary layer.

Figure 25  
Winter soil and landmine temperatures

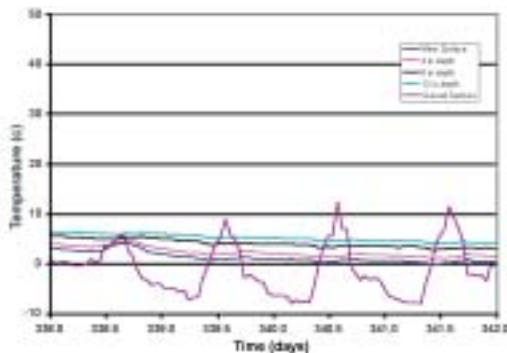
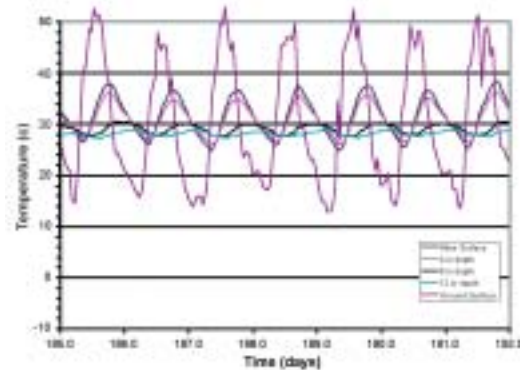

Figure 26  
Summer soil and landmine temperatures



As an example of the variation of soil surface temperature, Fig. 25 and 26 show the temperature of soil as a function of depth for high desert soil in Albuquerque, New Mexico, U.S. A TM62P anti-tank mine was buried in the soil 10cm below ground surface (to the top). These figures show the typical sinusoidal variations in soil temperatures caused by daytime net positive radiation (heating) and net negative night-time radiation (cooling). These temperature cycles dampen out as the depth increases. Note the significant surface temperature variation during the day. In the winter, the surface temperatures vary about 5 to 20°C during the day, while the temperatures at the top of the landmine vary by 4°C or less. The highest temperatures are in the early afternoon due to solar radiation, while the minimum temperatures are in the early morning before solar radiation becomes significant. During the summer months, the variation is more dramatic due to the higher level of solar radiation. While the timing is similar to that in the winter, the surface temperature variation in the summer is much higher at about 40°C, or about twice as large as during the winter. During the summer months, the temperature variation at the top of the mine is about 12°C during the day compared to a daily variation of 4°C during the winter.

### *Soil water content*

Water mass transfer in the soil occurs through a balance of the water added to the soil through net precipitation (precipitation minus runoff), water evaporated at the soil surface, and water that flows through the system to the underlying soil units. Retention and transport of water in the soil is influenced by the soil characteristics, such as the amount of clay present, and by other properties such as the porosity and the unsaturated soil characteristic curves. Weather affects the soil water content dramatically through precipitation at the surface, and the atmospheric water vapour pressure, which directly influences evaporation. (The term relative humidity is often used, that is simply the water vapour pressure divided by the saturated value.) The saturated water vapour pressure increases with increasing temperature. If the atmospheric vapour pressure is higher, evaporation will be reduced. Therefore, evaporation is smaller for higher relative humidity conditions, which will increase the soil water content. If the soil surface temperature is increased, the evaporation rate will be higher, decreasing the soil water content.

The soil water content dramatically affects the chemical partitioning among the phases (gas, liquid, solid) including sorption, as well as the gas and liquid transport (convection plus diffusion). At low soil saturations (< 10%), the amount of chemical vapour available for sensing drops dramatically as discussed earlier in Section 5, *Chemical distribution in soils*.

There are competing effects between the soil surface temperature and the soil surface water content as illustrated by an increase in soil surface temperature. While this increase will lead to an increase in Henry's constant, which in turn leads to a higher gas-phase chemical concentration, the higher soil surface temperature also leads to a decrease in the surface moisture content due to evaporation, which would lower the gas-phase concentration for low liquid saturations where vapour-solid sorption becomes important. The net effect of an increased soil surface temperature on the gas-phase chemical concentration depends on the interaction between temperature and moisture content.

### *Air boundary layer*

The air boundary layer, which is the air layer just above the soil surface, is a complicated function of weather and soil conditions. The dogs need to sniff in the chemical boundary layer in order to locate the chemical signatures emanating from buried landmines.

In reality, there are numerous boundary layers at the soil surface. There are boundary layers for momentum (wind), water vapour, and heat (thermal) as well as for the chemicals emanating from the buried landmines. The behaviour of each of these boundary layers is a little different. Boundary layers develop and thicken with increasing distance from their origin. The wind, water vapour, and heat boundary layers are generally at equilibrium as the origin of the boundary condition may be at the edge of the field containing the landmines, which may be many hundreds of metres away. In contrast, the origin of the chemical boundary layer is above the landmine, so the chemical boundary layer has had little opportunity to develop and thicken. Thus, the chemical boundary layer, which is of utmost importance for sensing, is probably thin relative to the other boundary layers. Chemical concentration is highest at the soil surface and is rapidly diluted in the boundary layer, going to zero at the

edge or thickness of the chemical boundary layer. Thus, if the chemical boundary layer thickness were  $x$  cm, there will generally be no chemical signature  $x$  cm or more above the ground. The dominant factors determining the boundary layer thicknesses are the wind speed, the air temperature, and the soil surface temperature. As the wind speed increases, the boundary layers become thinner. Conversely, for calm conditions, the boundary layer thicknesses are much greater than for windy conditions.

The air and soil surface temperatures strongly influence the boundary layer thicknesses. If the soil surface temperature is higher than the air temperature, which typically happens in the daytime due to solar radiation, the boundary layers are unstable as small thermal convection air currents are created. The net effect is that the average boundary layer thickness is reduced. However, these thermal convection air currents also have the potential to transport landmine signature chemical vapours upwards beyond the “average” boundary layer thicknesses. Settles and Kester (2001) describe an example of intermittent thermals rising at speeds of 0.25 m/s and at frequencies of about four per minute. With the unpredictable nature of these currents, chemical concentrations may vary considerably as a dog passes through an area containing landmine signature soil residues.

Conversely, when the soil temperatures are lower than the air temperature, such as at night, a temperature inversion occurs and the boundary layers are stable. Wind velocities are often lower at night due to the stability of the boundary layers. Under these conditions, the boundary layer becomes thicker and dilution decreases, providing for optimum conditions for vapour sensing.

### *Effect of dogs*

The chemical boundary layer thickness and the chemical concentration within this boundary layer will be affected by the actions of a sniffing dog as discussed by Settles and Kester (2001). For example, if the dog exhales prior to sniffing, it will disturb the local boundary layers, further diluting the signal. When the dog does sniff, it is not clear what air volume is sampled by the dog (Chapter 2, Part 2). For example, depending on the sniffing rate and the proximity of the dog's nose to the ground, the dog may only sniff the air from the boundary layer above the soil surface, or it may sample air above and below the soil surface, which would have a higher chemical concentration than that in the boundary layer. If the dog's nose is close to the ground and the sniffing rate is sufficient, small soil particles with potentially orders of magnitude higher chemical concentrations than in the vapour could be entrained by the sniffing action and sampled by the dog. With the moist conditions in the dog's nose, the potential for the release of sorbed chemicals exists, especially if the surface soil is dry. These interactions have not been studied at the present time.

### *Plants*

The effect of plants was not included in the above discussion. The reason for this exclusion is that their impact on the chemical signature has not been evaluated. It is well known that the impact of plants will be to mitigate any variations of atmospheric conditions. For example, plants will shade the soil resulting in reduced solar radiation to the surface and lower surface temperatures. Plants act as a sink for water, which will affect the water content in the subsurface and surface soil. The impact of plants will be to increase the vapour pressure at the soil surface relative to the atmosphere resulting in reduced evaporation from the surface. Plants also act as a sink for landmine

chemicals, possibly transporting them to their leaves. The influence of plants on detection of chemical signatures from landmines needs to be examined further.

### Summary

The effect of weather conditions on the chemical concentration at the soil surface and in the boundary layer just above the surface is dynamic and very complex. The soil surface temperature and water content, which can dramatically influence the chemical vapour concentration at the surface, is a function of a number of dynamic parameters including solar radiation and precipitation. The boundary layers just above the soil surface, which control the dilution of the chemicals, are predominantly dependent on the wind speed and the temperature difference between the surface of the soil and the air temperature. The only way to thoroughly evaluate the dynamic influence of the weather conditions is through models and simulations, which are discussed in Section 9, *Landmine-soil-weather systems analysis*, below.

## 9. Landmine-soil-weather systems analysis

Previous sections in this report have described individual properties and the processes affecting the chemical signature from buried landmines including the effect of weather. Shown separately, these individual elements are complex. However, there are even more complex interdependencies among these elements that challenge our intuition to fully understand the impacts on the landmine chemical signature. For example, increased soil moisture releases sorbed landmine signature chemicals from soils causing significantly greater vapour levels. However, increased soil moisture also induces biochemical degradation that reduces the soil residues, which would decrease the vapour levels. If the increased soil moisture comes from an extended rainfall, soil chemical residues would be washed deeper into the soil profile, which also decreasing vapour levels. The interdependencies between the processes are complex and are difficult to evaluate *a priori*.

One method to understand these complex interdependencies is through the use of computer simulation tools. Computer simulations can efficiently evaluate numerous scenarios in a short time and can also provide estimates for vapour or soil residue values that may be difficult to measure or are below analytical chemical detection limits. However, computer simulations require input data from all of the individual properties and processes, which is no simple task. There are landmine signature chemical properties, soil phase partitioning properties, mine-specific flux processes, degradation processes and weather factors. Fortunately, many of these have been determined, but only from a limited set of soils and mine types, and recent weather data can be unavailable or incomplete.

The computer solves the mass, momentum and heat conservation equations for the various components using a step-by-step problem solving procedure (an algorithm). With the large number of interdependent actions, the computer must be fast for the results to be obtained in a short duration. With today's computers, an annual weather cycle driven simulation may only take a few hours to evaluate the annual variation of the chemical signature. The computer simulation output has much to offer for analysis and evaluation. Vapour concentrations over time can be compared to dog vapour sensing thresholds to assess whether dogs may miss mines as a result of the conditions used in the simulation. In addition, other correlations can be determined that help

define limits to certain conditions (e.g. rainfall, wind, temperature, season, time of day) that may be used to initiate or terminate mine dog work in the field.

While computer simulation results are extremely valuable in understanding these complex interdependencies, computer simulation results are not the truth. Simulation results provide estimates that are based on experimental data and soil-physics based computational science. Unknown errors may be found in our understanding of the fundamental soil-chemical processes, the interactions between these processes, and in the complex mathematics simulation tools required. However, when simulation results closely mimic experimental or field data from a system that combines several or many of these individual processes, our confidence grows that the simulation tools provide a reasonable representation of actual conditions.

As mentioned in Section 8, *Weather factors affecting chemical sensing*, the effect of plants has not been thoroughly examined. In the landmine-soil-weather systems analysis methods that are discussed below, bare soil has been assumed to date. In order to include the effect of plants, a methodology to include the impact of plants needs to be incorporated into the systems analysis approaches. Such an approach has been identified but not yet included as discussed later in this section.

### *Key information*

- The complex interactions between landmine signature chemicals, soil and weather require advanced computer simulation tools to determine the changes in vapour concentrations available as a cue to the mine detection dog.
- Several soil-physics based simulation models of varying complexity are available; however, advanced training is necessary to understand the appropriate model to use and to evaluate simulation results.
- Laboratory experiments combining multiple factors help to validate the accuracy of simulation model results. However, complete validation is nearly impossible because of the natural variability in all of the factors.
- Simulation models are best used to establish conditions appropriate for mine dog applications and those that should be avoided.
- Landmine signature chemical transport models have been developed that can now be used to assess situational scenarios for routine or troublesome field conditions.
- Situation-specific input data are needed for simulation models to produce realistic results.
- Data needs: mine-specific flux, soil-water partitioning coefficient, degradation rates and weather history.
- The effect of plants has not been included in landmine chemical signature simulation models.

### *Complex interdependencies*

Fig. 27 shows a simplified diagram of the principal landmine soil chemical interactions described in previous sections. Not included here are some of the complex soil hydraulic processes that influence soil moisture during precipitation and drainage such as hysteresis in the soil characteristic curves. These are important, but do not directly affect the soil-chemical processes included in this report. Most of these processes are included in the various simulation modeling tools to different degrees of sophistication.



Figure 27  
Complex interdependencies affecting landmine signature chemicals in soil

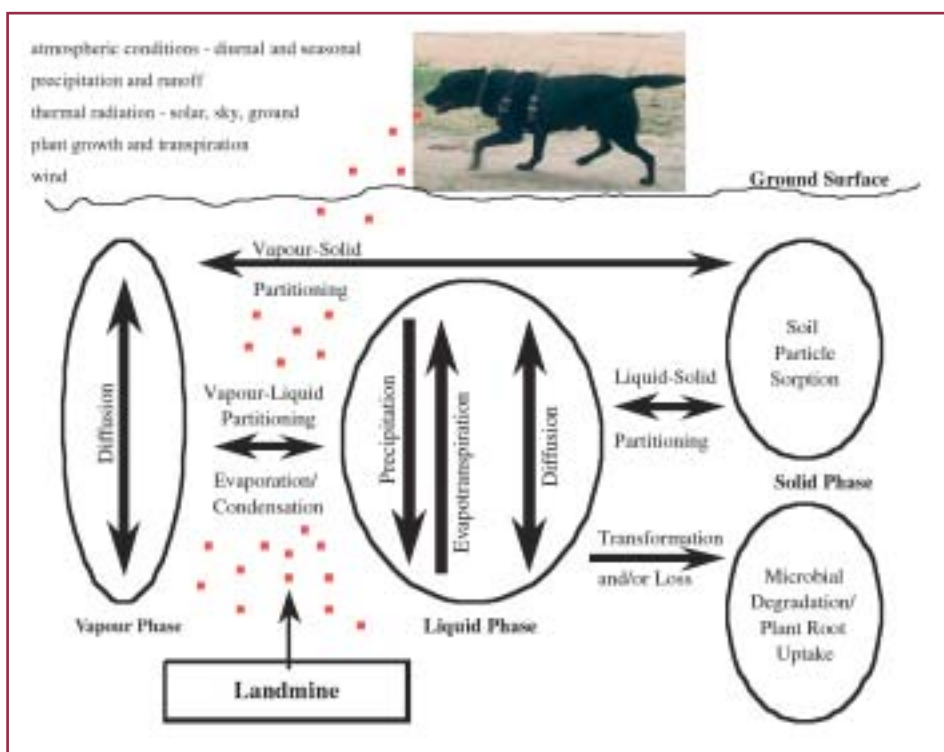

### Simulation modeling tools

A number of soil physics based simulation models have been used to evaluate the soil chemical interactions described in this report. Our initial analyses used a one-dimensional screening model developed to compare the pollution potential of various agricultural chemicals. This model is termed the Behaviour Assessment Model (BAM) (Jury *et al.*, 1983a, 1984a,b,c), which was later modified to become the Buried Chemical Model (BCM) (Jury *et al.*, 1990). These models used simplified approaches such as constant and uniform soil saturation and temperature, constant water flux, and a constant boundary layer thickness. As discussed in Section 8, *Weather factors affecting chemical sensing*, many of these parameters are highly variable in reality.

The BAM and BCM models were very useful in categorising the relative mobility, volatility and persistence of TNT, DNT and DNB chemicals in relation to other well-characterized agricultural chemicals. This initial analysis only required a simple set of input parameters: soil-water partitioning coefficient ( $K_d$ ), soil-air partitioning coefficient (Henry's constant,  $K_H$ ), diffusion coefficient in air ( $D_c$ ), and the bio-chemical half-life ( $T_{1/2}$ ).

The Buried Chemical Model was used to evaluate the effect of differing soil properties, water flux conditions and sequences on the behavior of TNT, DNT and DNB (Phelan and Webb, 1997). The surface vapour flux was evaluated because this parameter was considered to be the principal pathway for detection of buried landmines by dogs. This sensitivity analysis was presented in three conference proceedings (Phelan and Webb, 1998a; Phelan and Webb, 1998b; Webb *et al.*, 1998) and in a project report from



Dr. Jury (Jury and Guo, 1998). Table 19 shows the parameters evaluated and a summary of the impacts.

| Parameter                                 | Impact on steady state surface flux                     |
|---|---|
| Soil bulk density                         | Inversely proportional                                  |
| Henry's Law Constant                      | Directly proportional                                   |
| Soil-water partition coefficient          | Inversely proportional                                  |
| Source flux                               | Insignificant compared to initial surface concentration |
| Initial concentration                     | Directly proportional                                   |
| Burial depth                              | Increases lag time (very sensitive)                     |
| Water flux (precipitation or evaporation) | Evaporation enhances, precipitation depresses           |
| Biochemical half-life                     | Insensitive if > 1 year, very sensitive if < 60 days    |

Jury also performed a two-dimensional analysis (Jury and Guo, 1998) to evaluate the surface soil spatial variation in vapour flux using similar assumptions to those in his BAM and BCM approaches. The results showed that the surface vapour flux was greatest directly above a source with a small halo up to twice the width of the buried source. The surface flux drops off exponentially with increasing lateral distance from the edge of the mine.

While the Buried Chemical Model was valuable for an initial assessment, the assumptions of constant and uniform liquid content and temperature, as well as a single boundary layer thickness, are obviously great simplifications. In order to address these and other issues, a multidimensional mechanistic code was modified for application to this problem. This code, which is based on the TOUGH code from Lawrence Berkeley Laboratory (Pruess, 1987, 1991), considers air, water vapour, and explosive chemical mass transport and heat flow in a porous media and is able to address many of these questions. This code has been named T2TNT (Webb *et al.*, 1999).

Modifications to TOUGH2 to produce T2TNT included the following:

**Chemical Components** — Landmines typically emit TNT, DNT, and DNB vapours. The behaviour of each of these chemicals is different (vapour pressure, vapour/liquid, liquid/solid, and vapour/solid partitioning), so each component is modeled separately with unique properties specified for each chemical.

**Gas Diffusion** — Gas diffusion can be an important transport mode for explosive vapours in the subsurface, especially for low moisture content conditions. In order to mechanistically model gas diffusion in a porous medium, the Dusty Gas Model (Webb, 1996) has been implemented.

**Liquid Diffusion** — Liquid diffusion can be a dominant transport mode for explosive vapours in the subsurface, especially for moderate and high moisture content conditions. Liquid diffusion was not present in the original version of TOUGH2. Liquid diffusion using Fick's Law has been included because of the significant chemical concentration in the liquid phase.

**Liquid-Solid Sorption** — The solid-liquid partition coefficient was determined to

be a fairly sensitive parameter for soil partitioning and transport (Phelan *et al.*, 1999). Laboratory determined values showed that the sorption isotherm is not linear and followed more of a Freundlich relationship (Phelan and Barnett, 2001). In addition, liquid-solid sorption may vary with soil moisture content (EPA, 1999). Thus, in T2TNT, options for a linear sorption isotherm and a Freundlich sorption isotherm have been included. Modification of sorption as a linear function of liquid saturation is also an option.

*Vapour-Solid Sorption* — Vapour-solid sorption is significant for explosive vapours at low soil moisture contents. The experimental data is well described by the Petersen *et al.* (1995) function, which was originally developed for volatile organic compounds. The Petersen *et al.* (1995) expression has been incorporated into T2TNT with chemical specific parameters.

*Biodegradation* — A simple first-order constant half-life approach has been implemented to model biodegradation of the explosive vapours. From Section 6, degradation has been shown to be a function of the soil moisture content and temperature. This function will be incorporated in a future version of T2TNT.

*Surface Boundary Conditions* — Due to the shallow burial depth of many landmines, the fluid conditions surrounding the landmine are strongly influenced by the surface conditions. The parameters necessary to adequately model the surface boundary conditions include: solar and long-wave radiation, the surface boundary layer that is a function of wind speed and soil-air temperature differences, precipitation and evaporation at the surface, plants and their root systems, and the diurnal and seasonal variation of these parameters.

The effect of surface boundary conditions including the boundary layer thicknesses and the effect of plants is complex. For inclusion into T2TNT, a number of existing models have been evaluated. As a result, the SiSPAT model developed by Braud *et al.* (1995) and Braud (1996), has been selected for inclusion into T2TNT with the kind permission of M. Vauchlin of LTHE in Grenoble, France. Subroutines from SiSPAT are included directly into T2TNT as necessary. SiSPAT has been successfully applied to a number of field studies as documented by Braud *et al.* (1995), Braud (1996), and Boulet *et al.* (1997), and more are in progress. Therefore, SiSPAT provides a well-documented and tested approach for modeling the soil-plant-atmosphere interface in the T2TNT code.

At the present time, the surface boundary conditions for a bare soil have been implemented, including the surface boundary layer, solar and long-wave radiation, precipitation, and other conditions including the diurnal and seasonal variation of the parameters. Incorporation of the plant portion of the SiSPAT model into T2TNT is planned for a future version.

*Capillary Pressure Curve* — The typical representation of the capillary pressure curve breaks down at low liquid saturations. The curve asymptotes to a liquid residual saturation where the capillary pressure goes to minus infinity. Below this residual saturation, the capillary pressure is undefined causing computational problems. In order to alleviate this situation, a methodology has been developed to extend the capillary pressure curve to include the dry region down to zero liquid saturation (Webb, 2000). This technique results in a finite value of the capillary pressure below liquid residual saturation, which agrees with the available data.

Calculation of the boundary layer thickness is a considerable task involving turbulence modeling and meteorological conditions in the atmosphere above the boundary layer.

Due to this complex behaviour, simplified techniques are usually employed based on similarity functions (Arya, 1988). The solution of these equations gives the total boundary layer resistance from the surface to a reference level, which is typically 10m for wind and 2m for temperature (Braud, 1996). Most of the resistance is in the first few centimetres directly above the soil surface. For simplicity, a stagnant boundary layer thickness is often defined, which is simply the boundary layer resistance divided by the appropriate diffusivity or thermal conductivity neglecting turbulent transport. This stagnant boundary layer thickness is much less than the physical value and is a lower bound on the physical boundary layer thickness.

Based on simplified turbulence profiles, most of the mixing and dilution takes place in a physical boundary layer thickness ten times the stagnant value. Thus, if the stagnant boundary layer thickness is 1 cm, the physical boundary layer thickness is approximately 10 cm. Of this thickness, about half the mixing and dilution takes place in the lower 10% of the boundary layer, or in the lower 1 cm in this example.

Figure 28  
Boundary layer thickness

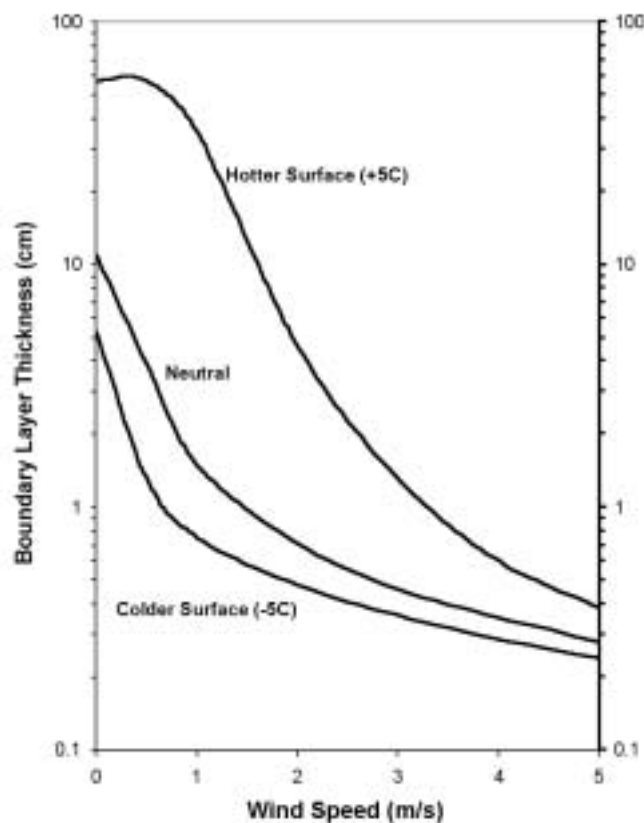

Based on the implementation in SiSPAT, Figure 28 shows the impact of the wind speed and soil-atmosphere temperature difference on the stagnant boundary layer thickness for water vapour. Under neutral conditions, where soil and air temperatures are equal, wind speeds greater than 1 m/s cause the stagnant boundary layer to diminish to less than 1 cm. Thus, the physical boundary layer for water vapour mass transfer is on the order of 10 cm. The chemical boundary layer thickness is smaller

than the water vapour value due to the differences in transport coefficients (Webb and Phelan, 2000) and the fact that the chemical boundary layer is developing. Thus, the chemical boundary layer is certainly much less than 10cm for these conditions. Dogs must sniff for landmine signature chemicals well within the chemical boundary layer or risk missing a mine vapour cue.

### Model validation

In order to evaluate the physics and to gain confidence in the T2TNT model, laboratory-scale soil column experiments were conducted. Laboratory-scale soil column experiments were designed after those of Petersen *et al.* (1996) and Spencer and Cliath (1973). Both methods used headspace measurements to estimate flux of organic chemical from the soil surface. We used the soil suction control apparatus of Spencer and the soil moisture measurement approach of Petersen *et al.* (1996) in our experiment. Fig. 29 shows a picture of the soil column test apparatus. Details of the experimental methods, parameter estimation and model formulation are described in Phelan *et al.*, 2000.

In the design of this test, soil moisture of about  $0.25 \text{ cm}^3 / \text{cm}^3$  was desired to maintain the soil pore space at about 50% liquid saturation. Thus, vapour-solid sorption is not a factor in these test results. Data from the water content reflectometers showed that the soil moisture distribution remained relatively constant over the test duration and showed an expected gradient with higher moisture contents at the bottom of the soil column.

DNT was added to the soil column 3.5 cm below the soil surface. The surface flux of DNT was measured in the experiment using Solid Phase Micro Extraction (SPME) fibers. The flux of DNT into the plenum increased by about a factor of  $10^4$  over the duration of the test (Fig. 30). The experiment was sacrificed on day 29 and samples were collected for soil moisture and DNT residues. Simulation results from T2TNT were compared to the data and are also shown in Figure 30. Based on the soil-water partitioning coefficient data the low range liquid-solid sorption coefficient,  $K_d$ , of 1.5 mL/g was selected for the initial simulations to compare to the data. As shown in Fig. 30, while the surface flux as a function of time has the right shape, the values are an order of magnitude or more below the experimental data.

The sensitivity of the  $K_d$  factor is readily apparent in Fig. 30. At this stage of the project, the Freundlich soil-water partitioning isotherm had not been incorporated into T2TNT. Another factor causing the discrepancy in values obtained from measured  $K_d$  versus data-model comparisons is in how the measured  $K_d$  is obtained. The low soil:water ratio in the batch equilibration  $K_d$  method allowed for near complete contact of the soil particle surface to the DNT in the water and allowed for migration into secondary porosity of soil minerals. In a soil column test this is not the case. Some proportion of soil surface area is not in contact with the water (and DNT) due to partial liquid saturation and surface-to-surface contact of soil particles. Because of the uncertainty in the value of  $K_d$  in the soil column test it was decided to vary the value of  $K_d$  until a reasonable match to the data was found as given in Fig. 30. The final value of  $K_d$  that

Figure 29  
Laboratory soil column test  
apparatus



matches the data reasonably well is  $\sim 0.5$  mL/g. The results from this initial test indicated that  $K_d$  may be influenced by partial saturation of the soils and that this should be considered in T2TNT. This phenomenon has been previously recognised (EPA, 1999); however, there have been mixed results to define the relationship of soil-water partition coefficient to soil saturation.

A second test was performed using the same apparatus and operating conditions. This test evaluated the effects of wetting and drying phenomena on the vapour flux of DNT at low liquid saturation, which include vapour-solid sorption phenomenon. Details of the materials, methods and results are given in Phelan *et al.* (2001a).

Figure 30  
Data model comparisons - effect of  $K_d$  value

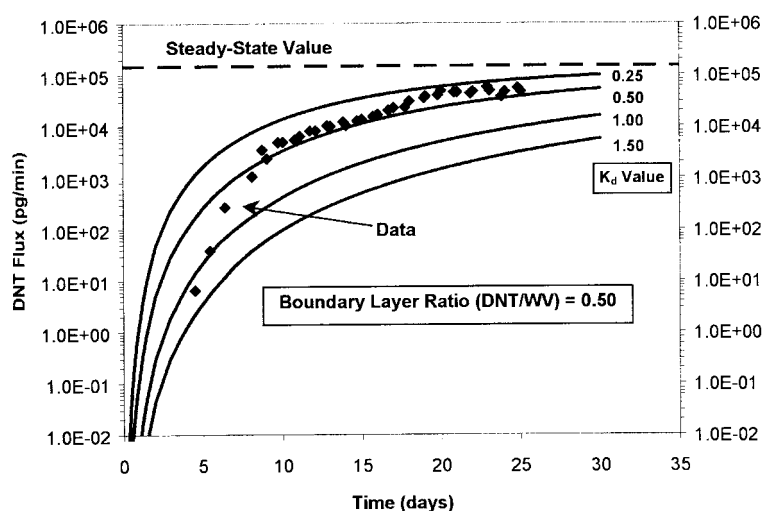

The data and model comparison for the surface flux of DNT that reflect the variation in soil column conditions are shown in Fig. 31. The initial relative humidity of the air was  $\sim 50\%$ . At Day 35, the relative humidity was changed to  $0\%$ , which increased the evaporation rate and the DNT vapour flux. At Day 44, a drying event was imposed that dramatically lowered the soil saturation and the DNT vapour flux. A wetting event at Day 69 significantly increased the DNT vapour flux and the soil saturation. Another wetting-drying cycle was imposed after Day 69 and can be clearly seen.

Unlike the prediction given by Phelan *et al.* (2000) in Fig. 30, no soil-water partitioning parameters were varied to try to improve the data-model comparison. However, T2TNT now includes a Freundlich isotherm for the soil-water partition coefficient, which is also weighted linearly as a function of soil saturation. The simulation results show excellent agreement with the data, especially considering the three order-of-magnitude variations during wetting-drying cycles. The initial surface flux out to 35 days is very close to the data including the transient variation up to that point. Up through Day 35, surface flux results from Test 1 and 2 were very consistent, demonstrating good control of fixed experimental parameters. In Test 2, the increase in the surface flux due to the change in the inlet air relative humidity at Day 35 is seen in the model predictions, although the magnitude of the increase is under predicted. The dramatic change in the surface flux data of about three orders of magnitude caused by the wetting and drying events is also reflected in the model predictions, including

the timing. The maximum differences are about a factor of 3, which is excellent considering the 5000-fold change in DNT surface flux.

Figure 31  
T2TNT data-model comparisons

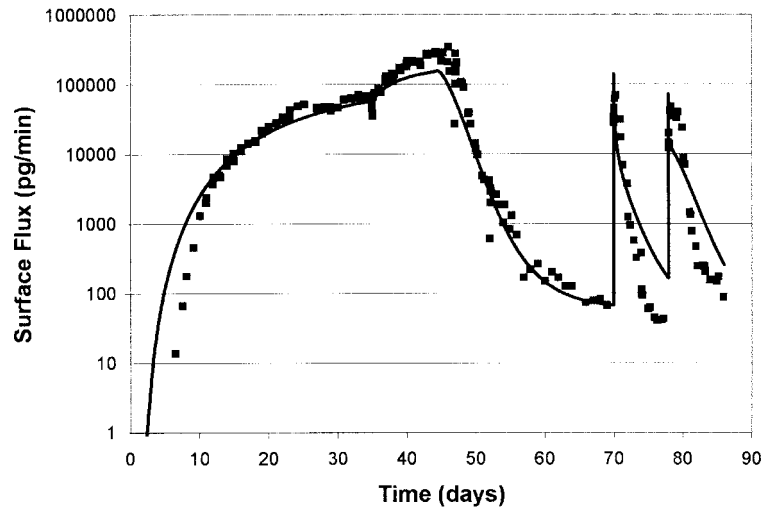

The data-model differences that occurred during the wetting and drying cycles may be due to hysteresis in the soil moisture characteristic curves. Hysteresis causes differences in the soil moisture content at a given soil tension during wetting and drying periods (Hillel, 1982). At low moisture contents, this can cause significant differences in model estimates (which uses a drying soil moisture characteristic curve) compared to experimental data. Unfortunately, measurement of wetting and drying soil-moisture characteristic curves would be laborious and may be unnecessary for this application.

The results from this test show how important soil-vapour partitioning can be to the vapour released by surface soils as indicated by the dramatic rise in the surface flux after wetting. In addition, the soil-water partition coefficient must be modeled with a Freundlich isotherm rather than a linear one, and the soil-water partition coefficient must be weighted for soil saturation. These test results give confidence in the predictive capability of the T2TNT code.

### *Demonstration calculations*

In order to estimate the influence of weather conditions, demonstration calculations have been performed. These calculations assumed a constant chemical source flux and a constant biodegradation rate for each chemical and used actual weather data. The results indicate the variability in the chemical concentrations on the soil surface over the long-term (one year) and the short-term (daily). Details on the input data requirements and simulation results can be found in Webb and Phelan (2000). The weather data from a standard weather station consisted of the following: atmospheric pressure, air temperature, relative humidity, solar radiation, precipitation, wind speed and wind direction at four elevations. In addition to these parameters, the long-wave radiation from the atmosphere must be included. Because it was not measured, long-wave radiation was estimated from measured weather parameters.



Fig. 32 (a) through (h) show the diurnal variation in T2TNT simulation results showing key factors of precipitation and resulting soil saturation, surface radiation balance and resulting soil temperatures at several depths, as well as the chemical concentrations of TNT, DNT and DNB expressed as total concentrations and as separate solid, liquid and gas phase concentrations. Of note is the dramatic increase in surface gas-phase concentrations of all three chemicals following a rainfall event.

Figures 33 (a) through (f) show the seasonal variation in T2TNT simulation results showing the surface soil liquid and gas phase concentrations of TNT, DNT and DNB. The seasonal variations in the liquid phase are impacted by changes in soil moisture due to precipitation and the gas phase variations are impacted by changes in the liquid phase concentrations and temperature effects on the vapour-liquid partitioning coefficient (Henry's Law Constant). Of note is the near uniformity of the maximum and minimum values indicated in Figure 33 (a) through (f). This is likely due to the fact that the source release rate and the degradation rate for each chemical are held constant over time, which is a significant simplification.

These demonstration calculations show the capabilities of T2TNT in expressing numerous interdependent input data and output results that are extremely valuable in understanding the complex phenomena in this problem. One aspect that requires yet more refinement is the variability of the degradation rate as a function of soil moisture and temperature, scaled according to soil type. In addition, the effect of plants on the results should be added to T2TNT.

### Summary

In this section, the individual soil-chemical interactions were combined into a complete landmine-soil-weather systems evaluation tool. This tool provides for the complex interdependent interactions that occur in the soil and produces estimates of the vapour concentrations and surface soil residues for comparison to mine dog performance capabilities. The effect of plants is currently not included in T2TNT. This tool can now be used to evaluate various scenarios — certain combinations of particular mine types (leakage), soil properties, and weather patterns. Differences in soil vapour emanations for scenarios in regional areas (Afghanistan, Angola, Cambodia, Mozambique) may demonstrate the critical nature of maintaining optimal mine dog performance or the futility of certain situations where vapour levels are well below typical mine dog vapour sensing capabilities.

## 10. Soil residues from landmines

Sampling and chemical analysis of soils (and vapour above soils) provides direct evidence of the type and magnitude of landmine signature chemicals available as cues for the dog. These measurements are valuable in understanding the true variations in soil residues and vapour concentrations as a function of mine type, soil type, and weather history. One unfortunate problem encountered, however, is that even with optimized sample collection, sample preparation and highly sensitive laboratory analytical chemistry methods, the net soil residue is often below method detection limits. This problem is even more acute for vapour sampling and analysis, as there is much less chemical in the vapour phase compared to the soil (Section 8, *Weather factors affecting chemical sensing*). However, when vapour levels are below detection limits but soil residues are detected, vapour concentrations above the soil can be estimated

Figure 32  
Diurnal variation of various parameters for the period 50-60 days

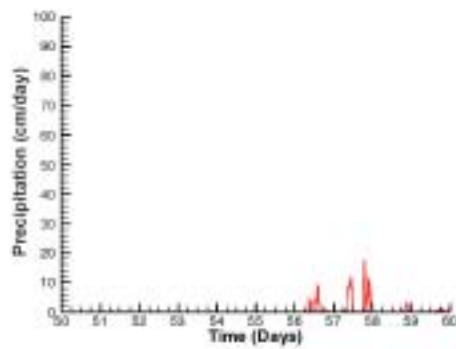

(a) Precipitation

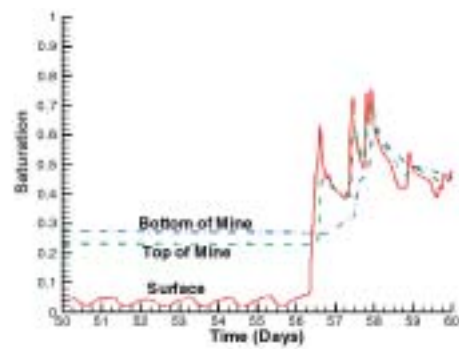

(b) Saturations

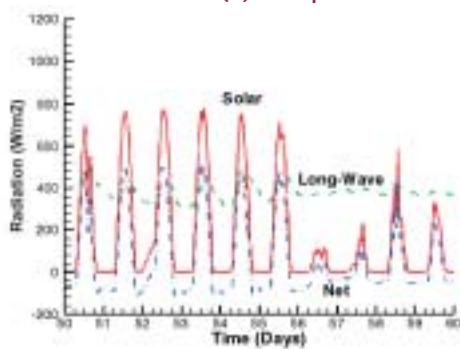

(c) Surface radiation balance

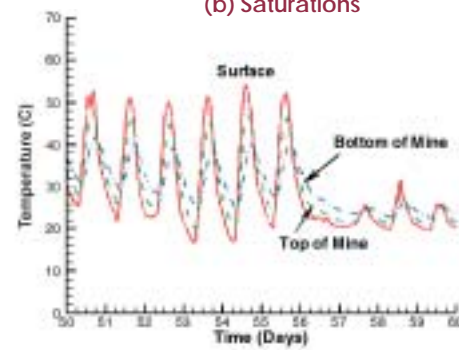

(d) Temperatures

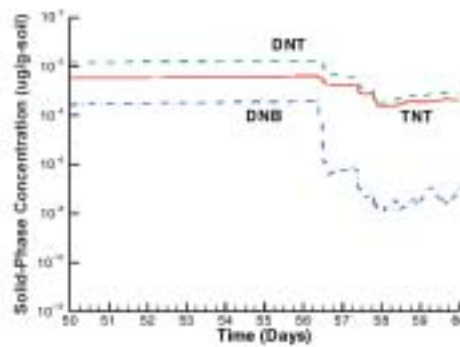

(e) Surface total concentration

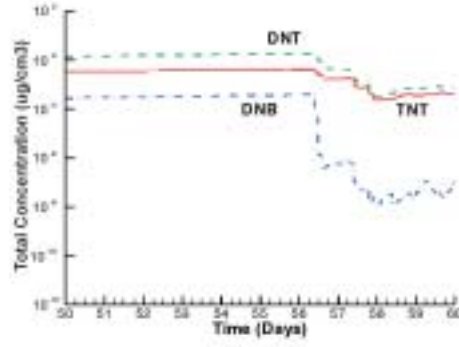

(f) Surface solid-phase concentration

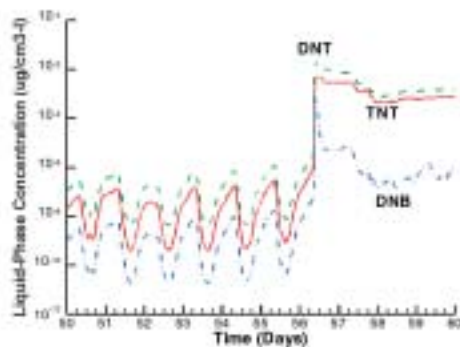

(g) Surface liquid-phase concentration

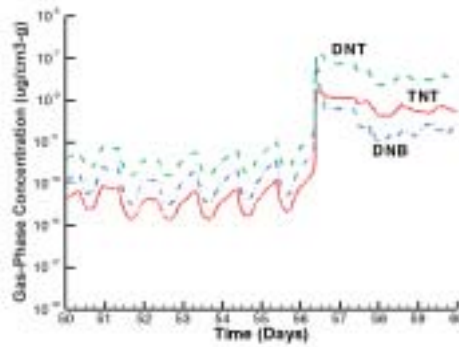

(h) Surface gas-phase concentration

Figure 33  
Seasonal variation of surface liquid- and gas-phase concentrations

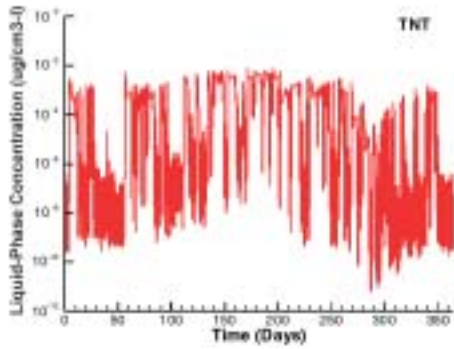

(a) Surface liquid-phase concentration of TNT

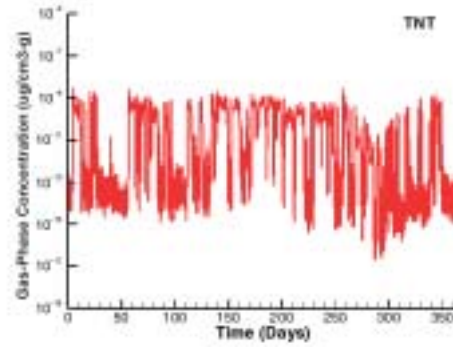

(b) Surface gas-phase concentration of TNT

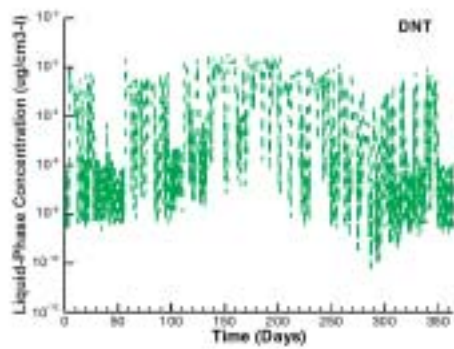

(c) Surface liquid-phase concentration of DNT

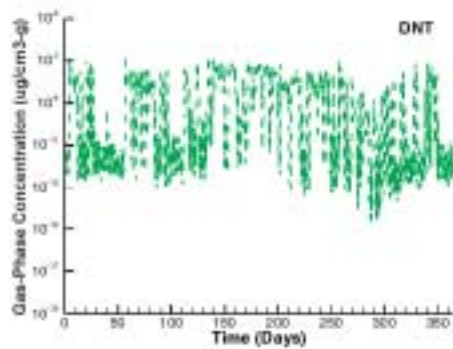

(d) Surface gas-phase concentration of DNT

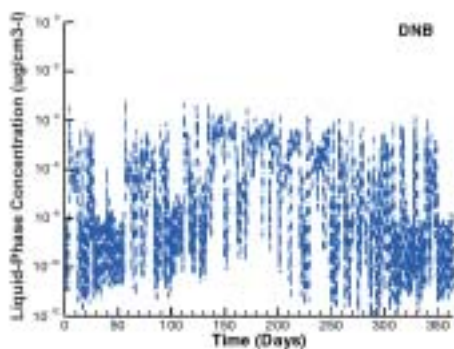

(e) Surface liquid-phase concentration of DNB

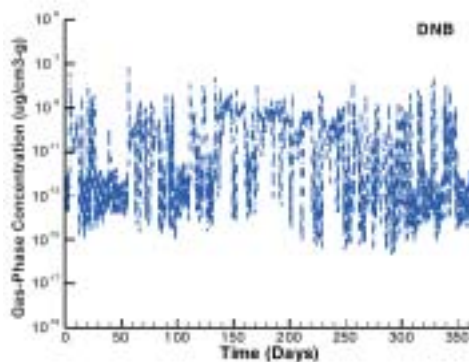

(f) Surface gas-phase concentration of DNB

using the phase partitioning relationships described in Section 5. These vapour levels, whether measured or estimated, can be compared with vapour sensing thresholds of individual mine detection dogs to evaluate the probability of detection for conditions specific to the mine type, soil type and weather history.

### *Key information*

- Chemical analysis of soil sample provides evidence of the actual amount of landmine signature chemicals from a landmine.
- Soil sample results have found TNT, DNT, 4A-DNT and 2A-DNT as the most prevalent landmine signature chemicals.
- Surface soil residues found are low, typically less than 100 ng/g.
- Soil sample method detection limits of 1–10 ng/g limit the measurement of lower concentrations that may still be useful in generating vapour cues for dogs.
- Soil residue values can be translated into vapour concentrations in the air boundary layer above soils for comparisons to dog vapour sensing thresholds.

### *Soil sampling and analytical methods*

Modern methods for soil sampling and chemical residue analysis developed for environmental pollution assessments (EPA SW846, 2002) can be used for landmine soil residue assessments. Sampling strategies have been developed that emphasize location specific (grab samples) or area specific (composite samples) with many recommendations for sample sizes compared to the area of interest. Composite samples combine several subsamples that provide an average over an area. The variation in soil residue values surrounding the landmine is lost in preference for an average over a larger area. For field landmine soil sampling, a grab sample is desired that provides a point value at that particular time while still leaving undisturbed areas for sampling at later dates. This method generates more samples, but at the same time provides a better description of the variation of soil residues surrounding the landmine. However, once a sample is collected degradation can still proceed. Options to halt the degradation process include processing the sample immediately (impractical for most field situations), storing the sample as cold as possible (on ice the temperature is 2–4°C, which can still allow degradation to occur), or air drying the sample (which causes a minor loss of ~10–15%, Cragin *et al.*, 1985).

Several laboratory chemical analysis methods are available to quantify the chemical residues in soils. After careful mixing, aliquots of soil (1 to 20 grams) are removed from the sample container, mixed with acetonitrile or acetone (1:4 ratio up to 1:1 ratio, weight/volume) and placed into a temperature controlled (10°C) ultrasonicator for up to 18 hours (Walsh and Ranney, 1999). Quantification can be performed via high-pressure liquid chromatography (EPA SW846 Method 8330), or by gas chromatography with either a electron capture detection (EPA SW846 Method 8095), thermionic detector (Hewitt *et al.*, 2001), nitrogen/phosphorus detector (Hewitt and Jenkins, 1999; Kjellstrom and Sarholm, 2000), or mass spectroscopy.

The analytical method detection limit is an important concept in landmine soil residue evaluations because frequently the analysis finds no chemical residue. This does not mean that no residue exists — it means that if there is any, it is below the detection limit for the chemical analysis method. Method detection limits vary with the soil, extraction method, and sensitivity of the instrumental method. Typical method detection limits for TNT and DNT are about 1 to 10 ng/g.

### Soil residues

Several studies have evaluated specific mine types on single occasions; however, due to the large time and resource commitment necessary to monitor soil residues over time, there have been few studies that have evaluated seasonal variations in soil residues. Chambers *et al.* (1998) report soil residues after 150 days since burial of a TM62-P antitank mine. Surface soil values for TNT were very large (2030 ng/g) and DNT was below the method detection limit (<10 ng/g). Subsurface values ranged from 20 to 160 ng/g TNT and 20 to 2,700 ng/g DNT from above and to the side of the mine. Desilets *et al.* (1998) measured soil residues from unspecified antitank mines ten months after burial and found TNT residues of 2 to >8 ng/g using a prototype soil-solvent extraction ion mobility spectroscopy analyser.

Kjellstrom and Sarholm (2000) reported on soil samples obtained from anti-tank and anti-personnel mines in Bosnia and Herzegovina that had been buried for three months and three years in both a deciduous forest and a gravel road. Selected sample results are shown in Table 20.

| Analyte        | PMA2 <sup>a)</sup> | TMA4 <sup>a)</sup> | TMA4 <sup>b)</sup> |
|----------------|--------------------|--------------------|--------------------|
| TNT (ng/g)     | 720                | 96                 | 160                |
| 2,4-DNT (ng/g) | 110                | 380                | 5,400              |
| 1,3-DNB (ng/g) | 83                 | -                  | 600                |
| 2A-DNT (ng/g)  | 160                | 16                 | 1,600              |
| 4A-DNT (ng/g)  | 210                | 28                 | 690                |

<sup>a)</sup> gravel road

<sup>b)</sup> deciduous forest

Source: Kjellstrom and Sarholm (1998).

The only multi-season landmine soil residue data set came from a long-term monitoring project at the DARPA developed Fort Leonard Wood Site. Jenkins *et al.* (2000) report on about 1,000 soil residues taken over four sampling events spanning 16 months since burial. Over this time period, soil samples were obtained surrounding the following landmines: TMA5, TMM-1, PMA-1A, PMA2, Type 72. Some very important observations were found through this effort:

- Surface soil samples did not always show detectable residues at every sample location. In some cases, detectable residues were more frequently found beyond the boundary of the landmine than directly above it.
- The three most prevalent compounds were 2,4,6-TNT, 2,4-DNT and both 4A-DNT and 2A-DNT (degradation by-products of TNT).
- The frequency that surface samples detected a specific analyte at a specific landmine type was typically less than 50% (i.e. less than half of samples taken had detectable residues).
- Over the five sampling events, the frequency of detection typically increased (i.e. more samples found detectable residues as time progressed).
- Table 21 presents a summary of the surface soil residues showing.
- Frequency of detection ranges from 10 to 48% over a large number of samples.
- TNT residues are much lower than DNT.
- DNB residues were generally absent (faster degradation, lower soil sorption, greater volatility).



- 2A-DNT and 4A-DNT typically show much greater values.
- Phase partitioning parameters for these compounds have not been compiled or measured; however, vapour pressure values for these compounds have been reported to be 1,000 times less than TNT, implying that these compounds will have minimal vapour concentrations compared to TNT or DNT.
- Median values (half of the sample set are greater and half less than this value) are very low for all compounds.

| Table 21<br>Summary of surface soil residues (ng/g) collected near mines in<br>August 1998 and April, July, November 1999 |          |                |         |      |        |
|---|----------|----------------|---------|------|--------|
| Chemical  | Analyses | Detections (%) | Maximum | Mean | Median |
| <b>TMA 5</b>  |          |                |         |      |        |
| 2,4,6-TNT   | 172      | 33 (19)        | 44      | 8    | 4      |
| 2,4-DNT   | 172      | 37 (22)        | 248     | 34   | 16     |
| 2A-DNT  | 172      | 48 (28)        | 685     | 62   | 17     |
| 4A-DNT  | 172      | 48 (28)        | 586     | 60   | 17     |
| <b>PMA-1A</b>   |          |                |         |      |        |
| 2,4,6-TNT   | 95       | 10 (11)        | 2       | 4    | 4      |
| 2,4-DNT   | 95       | 25 (26)        | 227     | 8    | 32     |
| 2A-DNT  | 95       | 27 (28)        | 600     | 109  | 44     |
| 4A-DNT  | 95       | 31 (33)        | 459     | 112  | 44     |

Source: Jenkins *et al.* (2000).

Fig. 34 shows data on the surface soil spatial distribution of 2,4-DNT surrounding a TMA-5 and PMA1A landmine (Hewitt *et al.*, 2001). Soil residues varied greatly in the vicinity of the landmine, but also showed a directional vector downslope. This has been attributed to surface water runoff transport of soil residues as particles or redeposition of DNT as a solute.

Figure 34  
Spatial distribution of 2,4-DNT (ng/g) in surface soils near TMA-5 (left) and PMA1A (right)

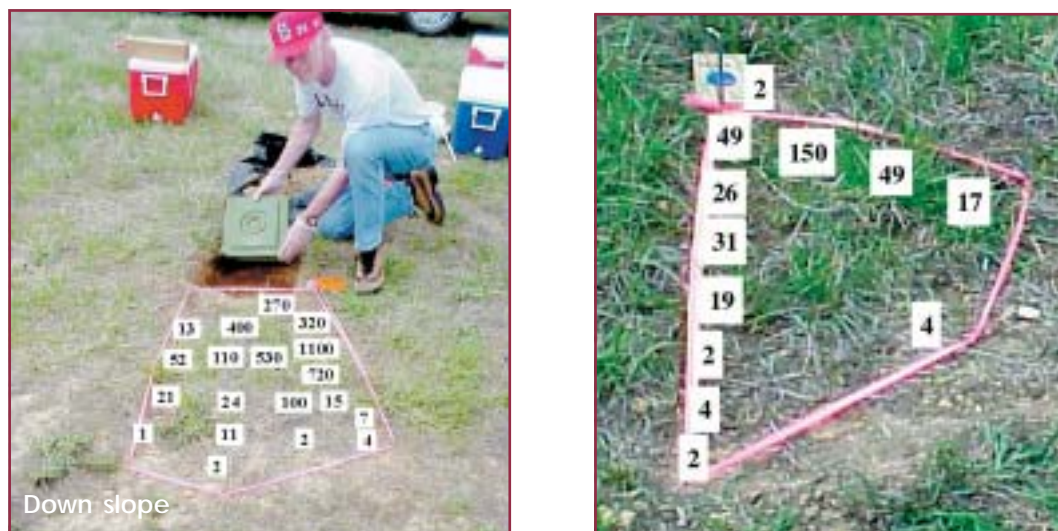

Source: Hewitt *et al.* (2001).



### Vapour concentration estimates

Reports on vapour samples from landmines in the field are rare. The probability of detecting a landmine signature vapour with current equipment is low because the vapour concentrations are extremely small. Jenkins *et al.* (2000) used higher soil residue samples from the Fort Leonard Wood mine site and sampled the headspace in a small vial. Soil/air partition coefficients ( $K_{s/a}$ ) were calculated using the ratio of the soil residue to the vapour concentration. These coefficients are equivalent to the  $K_d$  coefficients described in Section 5. Calculated  $K_{s/a}$  values for TNT and DNT at soil moisture contents of 10 to 19% (wet weight) are very similar to the  $K_d$  values shown in Figure 14. In addition, values tabulated for 2A-DNT and 4A-DNT are only 15 to 18 times greater than for 2,4-DNT, indicating that these compounds may be another vapour available as a cue for the dog. Using median surface soil concentrations and median  $K_{s/a}$  values, Jenkins *et al.* (2000) estimated vapour concentrations in the air boundary layer above landmines ( Table 22).

| Chemical  | TMA5                 |     | PMA1A                |     |
|-----------|----------------------|-----|----------------------|-----|
|           | ng/L                 | ppt | ng/L                 | ppt |
| 2,4,6-TNT | $9.4 \times 10^{-4}$ | 0.1 | $8.5 \times 10^{-4}$ | 0.1 |
| 2,4-DNT   | $1.5 \times 10^{-1}$ | 20  | $3.0 \times 10^{-1}$ | 40  |
| 2A-DNT    | $9.0 \times 10^{-3}$ | 1   | $2.3 \times 10^{-2}$ | 3   |
| 4A-DNT    | $1.1 \times 10^{-2}$ | 1   | $2.0 \times 10^{-2}$ | 2   |

Source: Jenkins *et al.* (2000).

### Summary

Soil residues from samples obtained at the ground surface in close proximity to a landmine provide the best direct evidence on the amount of chemical signature available as a cue for a dog. Unfortunately, many of these measurements are found to be below the chemical analysis method detection limit. Nevertheless, soil residue values help tremendously in defining conditions promising for mine dog detection work. Summary statistics for one minefield (Fort Leonard Wood, U.S.) show that the principal landmine chemical signature compounds are TNT, DNT, 2A-DNT and 4A-DNT. The absence of DNB confounds much of the previous work (Sections 3 to 6) that indicated DNB should be a target compound. More work is needed to evaluate the reason for the absence of DNB in soils near landmines.

The two primary degradation by-products of TNT, 2A-DNT and 4A-DNT, have been frequently disregarded as unimportant vapour signatures for landmine detection on the judgement that the vapour pressure could be about 1,000 times lower than that of DNT. However, soil residues of 2A-DNT and 4A-DNT were frequently higher than that of either TNT or DNT, and laboratory headspace soil-air partition coefficient determinations indicate that 2A-DNT and 4A-DNT may be at higher vapour concentrations than previously considered. More work is needed to evaluate the significance of 2A-DNT and 4A-DNT as a contributor to the landmine chemical vapour signature.

## 11. Vapour-sensing threshold of dogs

Scientific observation of the ability of dogs to locate hidden objects (lost people, contraband, and explosives) by vapour sensing has occurred over the last century. However, very little work has been completed that describes how the dog can accomplish these amazing tasks. Only recently has work been performed that has explored the chemical compounds dogs use to recognise landmines (Johnston *et al.*, 1998), the aerodynamics of how the dog inhales vapours and aerosols (Settles and Kester, 2001), and compared the performance of dogs to laboratory instrumentation and detection thresholds for narcotics and other non-energetic materials (Furton and Meyers, 2001).

### *Key information*

- Vapour sensing thresholds of trained mine detection dogs are difficult to determine because the dogs' capabilities are so much greater than laboratory chemical measurement instrumentation.
- The psychology of dog testing is very important because the dog can find alternative methods to achieve a reward and confound the testing regime.
- Some dogs that were trained only on TNT could also find DNT.
- Some dogs could not recognise even the highest vapour standards.
- Some dogs could sense down to the limits of one molecule per sniff, but not all dogs could reach this level.
- Variations in training history and operational methods also translated into differing capabilities.

### *Vapour-sensing threshold screening tests*

In an initial effort to determine the lower vapour sensing thresholds for landmine detection dogs, Phelan and Barnett (2002) prepared soil samples containing known residues of TNT or DNT and, by tenfold dilution (decade), produced soil residues over a wide dynamic range. By using the phase partitioning relationships (Section 5), the headspace vapour concentrations present adjacent to these soils were estimated.

Table 22 shows the typical soil residues measured before presentation to the dogs. In order to determine the extremely low sensing thresholds of the dogs, the soil samples were diluted below the soil analytical method detection limit. Because the soil dilutions demonstrated a linear decade decline, values below the method detection limit were extrapolated from the last measurable value. Also, the reader must be cautioned in the accuracy of the estimated headspace vapour concentrations, because small variations (1%) in soil moisture in dry soils creates larger variations (~ 100 fold) in headspace vapour concentrations. Nevertheless, this method was successful as a screening tool to determine the vapour sensing threshold of trained mine detection dogs. Fig. 35 and 36 show the headspace vapour concentrations of the TNT and DNT as a function of soil moisture content for the soil residues shown in Table 23.

Three groups of mine detection dogs trained by different means were presented these vapours on four different occasions and with different methods. Each dog training organization expressed the importance of presenting the test samples to the dogs in a manner in which they were accustomed, so that they were not distracted by the novelty

of a new item or require additional training specific to the test sample. Figs. 37 to 40 show the soil vapour standards in the various test configurations.

**Table 23**  
Decade dilution soil residues (ng/g)

| Jar | TNT    | DNT   |
|-----|--------|-------|
| T-1 | 98,320 |       |
| T-2 | 11,060 |       |
| T-3 | 1,080  |       |
| T-4 | 100    |       |
| T-5 | 11     |       |
| T-6 | 1      |       |
| T-7 | <MDL   |       |
| T-8 | <MDL   | <MDL  |
| D-1 |        | 6,850 |
| D-2 |        | 650   |
| D-3 |        | 61    |
| D-4 |        | 6     |
| D-5 |        | <MDL  |
| D-6 |        | <MDL  |
| D-7 |        | <MDL  |
| D-8 |        | <MDL  |

MDL – minimum detection limit

Observations from this work showed:

- Some dogs that were trained only on TNT could also find DNT.
- Some dogs could not recognise even the highest vapour standards.
- Some dogs could sense down to the limits of one molecule per sniff ( $10^{-10}$  ppt, see Table 5), but not all dogs could reach this level.
- Variations in training history and operational methods also translated into differing capabilities.
- The psychology of dog testing becomes very important as the dog can find alternative methods to achieve a reward and confound the testing regime.

**Figure 35**  
TNT soil headspace concentrations as a function of soil moisture content

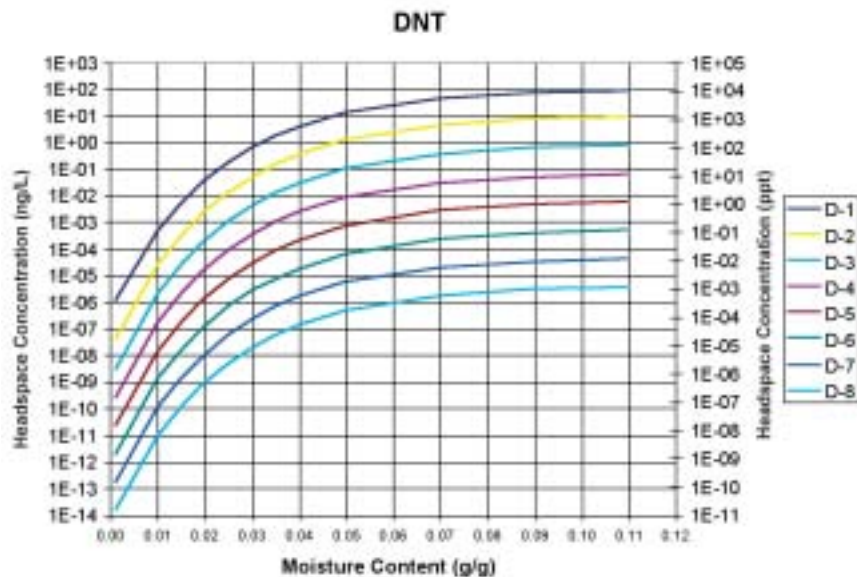

Figure 36  
DNT soil headspace concentrations as a function of soil moisture content

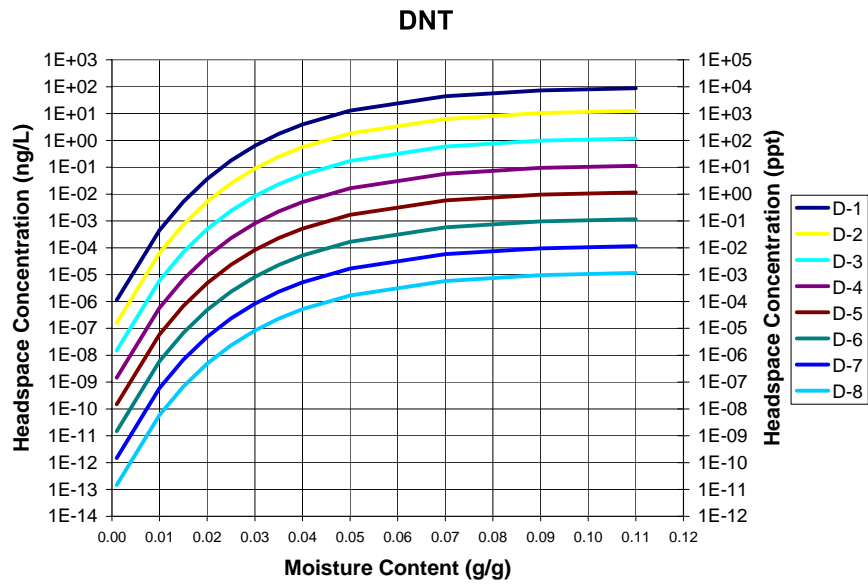

Figure 37  
Jar in testing station



Figure 38  
MEDDS vapour sample presentation method



Figure 39  
MEDDS filter soil vapour generator



Figure 40  
REST sample presentation method



### *Sensing by soil particle inhalation*

The initial focus of the vapour-sensing threshold testing was to determine if soil particle inhalation was a significant mechanism in the dogs' ability to detect buried landmines. Soil particles containing trace amounts of TNT or DNT produce extremely dilute vapour levels. Wetting dry soil particles displaces the TNT or DNT, producing large increases in vapour levels ( $\sim 10^5$ ). TNT and DNT soil residues were created to produce a vapour level below which the dogs could not identify. If the dogs could recognise the odour upon inhalation of these dry soil particles, then this implies that moisture in the dogs' nose releases sorbed vapours. Inhalation of dry soil particles therefore becomes an important mechanism contributing to the low detection capability. Fig. 41 shows the original planned testing regime that would allow headspace vapour levels to span almost ten orders of magnitude. However, the higher range of headspace chemical signature vapour levels under wet conditions was abandoned after the first set of mine detection dogs were found to be able to recognise the low concentration vapours from the dry soils. While landmine detection by inhalation of soil particles containing sorbed TNT or DNT may be another mechanism for successful recognition, it is not necessary because of the excellent trace vapour detection capabilities of the dogs.

Figure 41  
Initial testing strategy

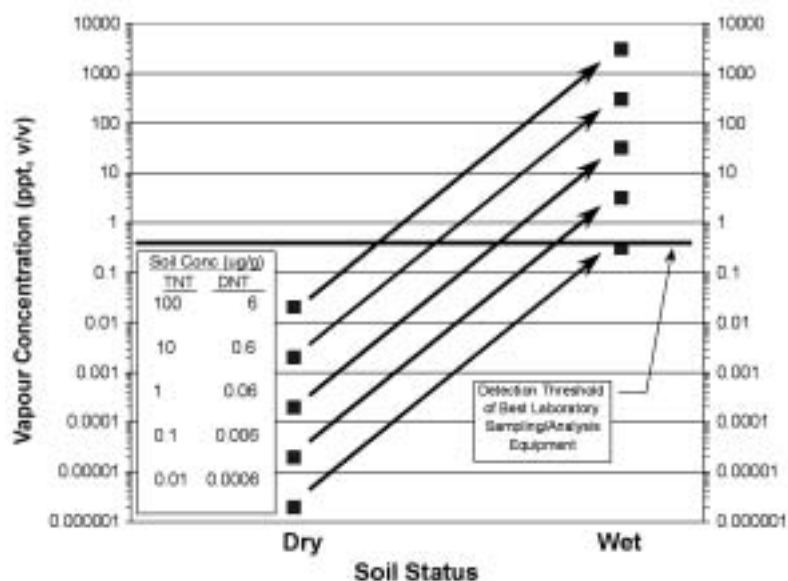

### *Comparison with vapour estimates from field landmine soil residues*

At the end of Section 10, a summary of surface soil samples from buried landmines was presented. Surface soil residues of landmine signature chemicals were not always measurable, but when detectable, were typically in the range of 1 to 100 ng/g (Table 21). For TNT, this translates into a T-4 to T-6 dog testing level (Table 23). For DNT, this is about a D-3 to D-5 level. Dogs therefore need to be consistently working at the T-6 or D-5 level to be successful in detecting landmines in dry soil conditions. However, in moist soil, this requirement may be relaxed to a T-4 or D-3 levels as more vapour is present with moist soils compared to dry soils.

We must recognise that these are generalities and mine dog vapour-sensing performance must ultimately be linked to the specific mine flux, soil type and weather cycle combination for a particular mine action problem. Much more work is needed to correlate landmine soil residues and mine dog vapour sensing performance to establish minimum mine dog qualification standards.

### *Summary*

The vapour-sensing capabilities of dogs are almost universally undisputed: however, measuring the dogs performance at ultra-trace vapour levels is difficult because the sensitivity of chemical measurement technology is far inferior to that of the dog. Initial screening methods to determine the vapour sensing threshold of dogs were developed using soil headspace vapour sources that were quantified by extrapolation beyond measurable levels in soils and estimation methods that correlate soil residues to vapour concentrations. Even with the uncertainty in this initial screening method, the method confirms the ultra-trace vapour-sensing capabilities of the dog. However, there were differences noted in the sensitivity of different dogs, in the sensitivity in a single dog on sequential days, and in the reliability of an individual dog at a given vapour level. Much more work is needed to establish the probability and reliability of detection as a function of training and working history, breed, and other factors yet to be determined.

## 12. Summary

Trace chemical detection of buried landmines is a complex subject; however, when carefully analysed, the complexities can be separated into individual elements for study, comparison and evaluation. This report has summarised the data, information, and conclusions from previous research efforts in analytical chemistry, soil physics, and computational simulation.

The principal objective of this effort is to communicate the nature of the landmine chemical signature, the impact of environmental conditions on this signature, and methods to compare expected chemical concentrations available as a cue to the performance capabilities of a trace chemical detector, such as the trained mine detection dog. To meet this objective, this report has focused on quantitative analysis, demanding much of the reader in understanding the world of small numbers, scientific notation, and units of measure not normally encountered outside of scientific and engineering literature.

After an introduction to numbers and nomenclature in chemistry, we examined the odour of landmines and which chemicals contribute to the vapour signature of military grade TNT. Three target compounds comprise the majority of the vapour signature - TNT, DNT and DNB. However, DNT and DNB, which are manufacturing impurities, are found in greater vapour concentrations than TNT due to the greater vapour pressure of each. The possibility that other chemicals in ultra-trace quantities contribute significantly to the odour signature cannot be discounted. Thus, we have focused attention on the major vapour components until such time that new target odours become identified.

Landmines are constructed in an endless variety of materials and methods of assembly. Chemical emission from landmines is the first step in the movement of the chemical



signature through soils. Measurements of landmine emissions have shown that the nature of the casing material makes a significant difference on the chemical emission rate. Landmines with rubber casing parts release significantly greater landmine chemical signatures than those with dense plastic casings such as PVC. The amount of chemical released by many landmines is surprisingly large; however, before reaching the ground surface, much of the chemical is lost in sorption and degradation processes. Many more measurements of the unique, individual landmine chemical emissions are needed for comparative analysis of the ease or difficulty of detection.

Once released from the landmine, the chemical signature engages in a complex exchange, distributing the mass of chemical between the soil air, soil water and onto soil particles. Each landmine chemical behaves differently, which affects the mobility and concentration available as a cue for the dog. The most dramatic effect observed is during a transition of soil moisture from very dry conditions to slightly damp. Dry soil has few water molecules sorbed to the surface. The very large surface area of soils provides a tremendous surface for sorption of landmine signature chemicals from the vapour phase. Dry soil containing landmine signature residues will have very low vapour concentrations due to this vapour-solid sorption phenomenon. However, when wetted, the water displaces the landmine signature chemicals, increasing the vapour concentrations a tremendous amount (e.g. 10,000 to 100,000 fold). We are only beginning to understand how this impacts mine dog performance in the field. For example, in perennially dry soil conditions such as Afghanistan, why are the mine detection dogs so successful in finding buried landmines? Instead of vapours, the dogs may inhale suspended soil particles containing landmine signature chemicals. When these dry particles contact wet surfaces inside the dogs' nose, the landmine signature chemicals may be displaced providing the cue for the dog. In contrast, many deminers have expressed that landmines can be found much easier in the early morning hours before the nightly dew and surface soil moisture has been lost to evaporation.

The benefit of soil moisture in releasing sorbed landmine signature chemicals is apparent as described above. However, soil moisture also initiates the degradation process, which can cause rapid loss of the valuable landmine signature chemicals. With dry soil conditions, the loss is not measurable, and the soil can be considered an excellent storage media. However, when the soil becomes just damp, the biological and abiotic degradation processes begin working fast, where the half-life (the time where half the mass is lost) is measured as just a day or slightly more. Without constant landmine chemical emissions, a wet soil would consume the majority of the chemical stored on the soil in a matter of days. The complex nature of degradation has challenged many research projects, and the conventional environmental engineering descriptors poorly describe the nature of this process. As such, much more work is needed to better describe these processes.

Up to this point, this report has described individual processes occurring in the landmine and the soil. However, the local weather conditions are the principal drivers for moving the chemical signature through the soils. Rainfall, evaporation, solar radiation, heat, cold, and wind contribute to complex processes near the soil surface. Because the landmine is in the near surface soils and the mine detection dog is sniffing for chemical signatures from the air, these interactions are very important. Of all of the knowledge on landmine chemical sensing, this topic is the least well understood. The sharp contrast between soil physics processes and atmospheric physics in the layers closest to the ground, with a driving force of weather that affects both, creates

a very complex interacting process with few applications from similar problems (e.g. agricultural chemical emissions). Chemical mass transport from the landmine to the soil surface and into the air is a very localised process, where averaging over larger scales does not make sense. Much more research is needed with specialised expertise to improve our knowledge in this critical area.

Chemical transport in soils has been a well-studied aspect of soil physics. Chemical diffusion in vapour and water in soil are well described from gas and solute diffusivity, air and water filled porosity, and soil-water and soil-vapour sorption. Chemical convection combines the mass transport of water, through precipitation downward and evaporation upward, and the temperature dependent solubility of each chemical in water.

As the story of trace chemical detection of buried landmines unfolds, we find there are many individual complex processes along the way. Understanding each one individually is a challenge; however, the combination of all of these is an even greater challenge. We begin to lose our intuitive ability to judge the impact of the summation of all of these processes. Therefore, we have engaged the use of simulation modeling tools, which can combine most of the processes and provide a wealth of insight into the amount of landmine chemical signature available as a cue for trace chemical detection. These simulation models require sophisticated computers with high speed to complete an analysis of an annual weather cycle. The coupling of simulation models for soil transport and atmospheric transport of chemicals has yet to be made. When available, this will provide a key tool, because the processes for atmospheric dispersion of the landmine signature chemicals emitted from the soil surface is key to understanding the probability of detection under specific landmine-soil-weather conditions.

The measurement of soil residues from actual landmines in the field provides us with an understanding of the variability inherent in natural processes. The heterogeneous nature of soils and the variability in each of the unit processes described in the report, create a reality that is nearly impossible to model. Efforts to characterise the actual soil residues from landmines have also been challenged, because the ultra-trace nature of these soil residues is frequently below advanced technology's most capable method detection limits. However, when measurable, the results indicate that the soil residues are not uniform, and the greatest concentrations are not always directly over the landmine. Surface runoff after a rain can move the landmine chemical signature downslope, creating a smear of soil residue some distance from the actual landmine. The importance of measurement of actual soil residues cannot be underestimated. This provides the reality check for simulation modeling, for comparison to the performance and vapour sensing threshold of mine detection dogs, and for situational analysis to understand what combinations of mines, soil and weather will provide sufficient chemical for trace chemical detection.

As dogs are actively engaged in mine detection work, it is reasonable to assume that the vapour-sensing thresholds and performance capabilities have been carefully measured. This is not the case. Only recently have we begun to measure the vapour sensing thresholds of trained mine detection dogs. This has been difficult, because the dogs' vapour-sensing capability far surpasses the capability of modern measurement techniques. Even so, with extrapolation and estimation techniques, we find that the dog is capable of sensing at extraordinary low levels, levels that approach that of one molecule per sniff. More research is needed to measure the vapour sensing

performance of greater numbers of individual dogs, including the reliability at these extremely low concentrations.

This report demonstrates the complex physics involved in chemical transport from buried landmines, including the interdependencies between the various processes. While much knowledge has been obtained in the last few years, additional information is needed to improve our ability to predict chemical movement from buried landmines.

We hope that this report provides a resource for those seeking to understand the fundamental processes that affect chemical sensing for buried landmines, and those seeking to fill in needed information to improve our understanding of trace chemical detection of buried landmines. The current numbers of buried landmines that need to be found is astounding, providing decades of work for mine action centres worldwide. With the placement of new buried landmines from new and renewed conflicts, more resources are needed to improve the currently working demining tool of trace chemical detection.

## Bibliography

- Arya, S.P. (1988)  
*Introduction to Micrometeorology*, Academic Press, San Diego.
- Auer L.H., N.D. Rosenberg, K.H. Birdsell and E.M. Whitney (1996)  
“The effects of barometric pumping on contaminant transport”, *Journal of Contaminant Hydrology*, 24:145-16.
- Bender, E.A., A. Hogan, D. Leggett, G. Miskolczy and S. MacDonald (1992)  
“Surface contamination by TNT”, *Journal of Forensic Sciences*, 37(6):1673-1678.
- Boulet, G., I. Braud and M. Vauclin (1997)  
“Study of the mechanisms of evaporation under arid conditions using a detailed model of the soil-atmosphere continuum. Application to the EFEDA I experiment”, *Journal of Hydrology*, 193:114-141.
- Braud, I. (1996)  
*SiSPAT User's Manual – Simple Soil Plant Atmosphere Transfer Model*, Version 2.0, LTHE, Grenoble, France.
- Braud, I., A.C. Dantas-Antonino, M. Vauclin, J.L. Thony and P. Ruelle (1995)  
“A simple soil-plant-atmosphere transfer model (SiSPAT) development and field verification”, *Journal of Hydrology*, 166:213-250.
- Burglsser, C.S., M. Cernik, M. Borkovec and H. Sticher (1993)  
“Determination of Nonlinear Adsorption Isotherms from Column Experiments: An Alternative to Batch Studies”, *Environmental Science & Technology*, 27(5):943-948.
- Campbell, G.S., and J.M. Norman (1998)  
*An Introduction to Environmental Biophysics*, Second Edition, Springer-Verlag, New York.
- Cataldo, D.A., S.D. Harvey and R.J. Fellows (1993)  
*The Environmental Behavior and Chemical Fate of Energetic Compounds (TNT, RDX, Tetryl) in Soil and Plant Systems*, Pacific Northwest Laboratory, Richland, WA. PNL-SA-22362, presented at the 17<sup>th</sup> Annual Army Environmental R&D Symposium and 3<sup>rd</sup> USACE Innovative Technology Transfer Workshop, 22-24 June 1993, Williamsburg, VA.
- Caton, J.E., C. Ho, R.T. Williams and W.H. Griest (1994)  
“Characterization of insoluble fractions of TNT transformed by composting”, *Journal of Environmental Science and Health*, A29:659-670.
- Cebeci, T., and P. Bradshaw (1984)  
*Physical and Computational Aspects of Convective Heat Transfer*, Springer-Verlag, New York.
- Chambers, W.B., P.J. Rodacy, E.E. Jones, B.J. Gomez and R.L. Woodfin (1998)  
“Chemical sensing system for classification of mine-like objects by explosives detection” in A.C. Dubey, J.F. Harvey and J.T. Broach (eds), *Proceedings of the SPIE 12<sup>th</sup> Annual International Symposium on Aerospace/Defense Sensing, Simulation and Controls, Detection and Remediation Technologies for Mines and Minelike Targets III*, April 13-17, 1998.
- Comfort, S.D., P.J. Shea, L.S. Hundal, Z. Li, B.L. Woodbury, J.L. Martin and W.L. Powers (1995)  
“TNT Transport and Fate in Contaminated Soil”, *Journal of Environmental Quality*, 24(6):1174-1182.

- Cooper, P. (1996)  
*Explosives Engineering*, Wiley-VCH. New York, NY.
- Cragin, J.H., D.C. Leggett, B.T. Foley and P.W. Schumacher (1985)  
*TNT, RDX and HMX explosives in soil and sediments – Analysis techniques and drying losses*, U.S. Army Cold Regions Research and Engineering Laboratory Report 85-15.
- Culver, T.B., C.A. Shoemaker and L.W. Lion (1991)  
“Impact of vapor sorption on the subsurface transport of volatile organic compounds: A numerical model and analysis”, *Water Resources Research*, 27:2259-2270.
- Desilets, S., L.V. Haley and U. Thekkadath (1998)  
“Trace explosives detection for finding land mines”, in A.C. Dubey, J.F. Harvey, J.T. Broach (eds), *Proceedings of the SPIE 12<sup>th</sup> Annual International Symposium on Aerospace/Defense Sensing, Simulation and Controls, Detection and Remediation Technologies for Mines and Minelike Targets III, April 13-17, 1998*.
- Dionne, B.C., D.P. Rounbehler, E.K. Achter, J.R. Hobbs and D.H. Fine (1986)  
“Vapor Pressure of Explosives”, *Journal of Energetic Materials*, 4:447-472.
- Dugan, R.E. (1996)  
*Detection of Land Mines and Unexploded Ordnance by Exploitation of the Chemical Signature*, Defense Advanced Research Projects Agency, Conference presentation, April.
- Ehlers, W., J. Letey, W. F. Spencer and W.J. Farmer (1969a)  
“Lindane Diffusion in Soils: I. Theoretical Considerations and Mechanism of Movement”, *Soil Science of America Proc.*, 33:501-504.
- \_\_\_\_\_ (1969b)  
Lindane Diffusion in Soils: II. Water Content, Bulk Density, and Temperature Effects, *Soil Science of America Proc.*, 33:505-508.
- EPA (1989)  
*Code of Federal Regulations, Subpart C – Transport Processes*, §796.2750 Sediment and soil adsorption isotherm, 50 FR 39252, Sept 27, 1985, as amended at 52 FR 19058, May 20, 1987; 54 FR 29715, 14 July.
- \_\_\_\_\_ (1999)  
*Understanding Variation in Partition Coefficient,  $K_d$ , Values*, United States Environmental Protection Agency, Office of Air and Radiation, EPA 402-R-99-004A, August.
- \_\_\_\_\_ (2002)  
*Test Methods for Evaluating Solid Wastes – Physical/Chemical Methods, On-Line*, United States Environmental Protection Agency, Office of Solid Waste.
- Falta, R.W., K. Pruess, S. Finsterle and A. Battistelli (1995)  
*T2VOC User’s Guide*, LBL-36400, Lawrence Berkeley Laboratory.
- Farmer, W.J., M.S. Yang, J. Letey and W.F. Spencer (1980)  
“Hexachlorobenzene: its vapor pressure and vapor phase diffusion in soil”, *Soil Sci. Soc. Am. Proc.*, 44:676-680.
- Furton, K. G., and L.J. Myers (2001)  
“The scientific foundation and efficacy of the use of canines as chemical detectors for explosives”, *Talanta*, 54:487-500.
- Geiger, R. (1957)  
*The Climate Near the Ground*, Harvard University Press, Cambridge, Massachusetts.

- George, V., T.F. Jenkins, D.C. Leggett, J.H. Cragin, J. Phelan, J. Oxley and J. Pennington (1999)  
“Progress to date on determining the vapor signature of a buried landmine” in A.C. Dubey, J.F. Harvey, J.T. Broach and R.E. Dugan (eds), *Proceedings of the SPIE 13<sup>th</sup> Annual International Symposium on Aerospace/Defense Sensing, Simulation and Controls, Detection and Remediation Technologies for Mines and Minelike Targets IV*, 5-9 April 5-9 1999, 3710:258-269.
- George, V., T.F. Jenkins, J.M. Phelan, D.C. Leggett, J. Oxley, S.W. Webb, P. H. Miyares, J. H. Cragin, J. Smith and T.E. Berry (2000)  
“Progress on determining the vapor signature of a buried landmine” in A.C. Dubey, J.F. Harvey, J. T. Broach and R.E. Dugan (eds), *Detection and Remediation Technologies for Mines and Minelike Targets V*, Proceedings of SPIE 4038.
- Gibbs, T.R., and A. Popolato (eds.) (1980)  
*LASL Explosive Property Data*, University of California Press.
- Grant, C.L., T.F. Jenkins and S.M. Golden (1993)  
*Experimental Assessment of Analytical Holding Times for Nitroaromatic and Nitramine Explosives in Soil*, U.S. Army Cold Regions Research and Engineering Laboratory Special Report 93-11, Hanover, New Hampshire, June.
- Hamaker, J.W. (1972)  
“Diffusion and volatilization”, in Goring and Hamaker (eds), *Organic Chemicals in the Soil Environment*, Volume 1, Marcel Dekker Inc., New York.
- Hewitt, A. D., and T.F. Jenkins (1999)  
*On-site method for measuring nitroaromatic and nitramine explosives in soil and groundwater using GC-NPD: feasibility study*, U.S. Army Corps of Engineers, Cold Regions Research and Engineering Laboratory Special Report 99-9.
- Hewitt, A. D., T. F. Jenkins, and T.A. Ranney (2001)  
*Field gas chromatography/thermionic detector system for on-site determination of explosives in soils*, U.S. Army Corps of Engineers, Engineer Research and Development Center, Cold Regions Research and Engineering Laboratory Technical Report ERDC/CRREL TR-01-9.
- Hillel, D. (1982)  
*Introduction to Soil Physics*, Academic Press Inc., San Diego, California.
- Hogan, A. W., D. C. Leggett and J. Lacombe (1990)  
*Environmental Influences on Mine Detection*, U.S. Army Corps of Engineers, Cold Regions Research and Engineering Laboratory, Special Report 90-31, August.
- Hogan, A.W., D.C. Leggett, T. Jenkins and P. Miyares (1992)  
*Surface Contamination of Depot-Stored Landmines: Results from Preliminary Analyses*, Memorandum to Defense Advanced Research Projects Agency, 23 June.
- Hundal, L.S., J. Singh, E.L. Bier, P.J. Shea, S.D. Comfort and W.L. Powers (1997)  
“Removal of TNT and RDX from Water and Soil Using Iron Metal”, *Environmental Pollution*, 97(1-2):55-64.
- Howard, P.H. (1990)  
*Handbook of Environmental Fate and Exposure Data for Organic Chemicals, Volume II: Solvents*, Lewis Publishers, Michigan.
- Jenkins, T.F., W. F. O'Reilly, R. P. Murrmann and C.I. Collins (1974)  
*Detection of Cyclohexanone in the Atmosphere Above Emplaced Antitank Mines*, U.S. Army Corps of Engineers, Cold Regions Research and Engineering Laboratory, Hanover, New Hampshire, Special Report 203, April.



- Jenkins, T.F., D.C. Leggett and R.P. Murrmann (1974)  
“Preliminary Investigation of the Permeability of Moist Soils to Explosive Vapor”,  
in Spangler, *Physical Model for the Subterranean Movement of Explosive Vapors from  
Mines*, Report MERADCOM-R-2095.
- Jenkins, T.F., D.C. Leggett and T.A. Ranney (1999)  
*Vapor signatures from military explosives, Part 1: Vapor transport from buried military  
grade TNT*, U.S. Army Cold Regions Research and Engineering Laboratory, Special  
Report 99-21, December.
- Jenkins, T.F., M.E. Walsh, P.H. Miyares, J. Kopczynski, T. Ranney, V. George, J.  
Pennington and T. Berry (2000)  
*Analysis of Explosives-Related Chemical Signatures in Soil Samples Collected Near Buried  
Landmines*, U.S. Army Corps of Engineers, Engineer Research and Development  
Center, Report ERDC TR-00-5, August.
- Jenkins, T.F., D.C. Leggett, P.H. Miyares, M. E. Walsh, T. A. Ranney, J. H. Cragin and  
V. George (2001)  
“Chemical signatures of TNT-filled land mines“, *Talanta*, 54:501-513.
- Johnston, J.M., M. Williams, L.P. Waggoner, C.C. Edge, R.E. Dugan and S.F. Hallowell  
(1998)  
“Canine Detection Odor Signatures for Mine-Related Explosives“, *Proceedings  
SPIE, Detection and Remediation Technologies for Mines and Minelike Targets III*,  
3392:490-501.
- Jury, W.A. and L. Guo (1998)  
*One Dimensional Transport of Vapor From A Buried Landmine*, Project report,  
University of California, Riverside, 20 July.
- Jury, W.A., R. Grover, W.F. Spencer and W. J. Farmer (1980)  
“Modeling Vapor Losses of Soil-Incorporated with Triallate“, *Soil Science Society  
of America Journal*, 44:445-50.
- Jury, W.A., W.F. Spencer and W.J. Farmer (1983)  
“Behavior Assessment Model for Trace Organics in Soil: I. Model Description“,  
*Journal of Environmental Quality*, 12(4):558-564.
- \_\_\_\_ (1984a)  
“Behavior Assessment Model for Trace Organics in Soil: II. Chemical  
Classification and Parameter Sensitivity“, *Journal of Environmental Quality*,  
13(4):567-572.
- \_\_\_\_ (1984b)  
“Behavior Assessment Model for Trace Organics in Soil: III. Application of  
Screening Model“, *Journal of Environmental Quality*, 13(4):573-579.
- \_\_\_\_ (1984)  
“Behavior Assessment Model for Trace Organics in Soil: IV. Review of  
Experimental Evidence“, *Journal of Environmental Quality*, 13(4):580-586.
- Jury, W.A., D. Russo, G. Streile and H. Abd (1990)  
“Evaluation of Volatilization by Organic Chemicals Residing Below the Surface“,  
*Water Resources Research*, 26 (1):13-20.
- Jury, W.A., W.R. Gardner and W.H. Gardner (1991)  
*Soil Physics*, Fifth Edition, John Wiley and Sons.
- Jury, W.A. and L. Guo (1998)  
*Two Dimensional Transport of Vapor From a Buried Landmine*, draft project report,  
University of California, Riverside, 1 September.

- Kaplan, D.L., and A.M. Kaplan (1982)  
“2,4,6-trinitrotoluene-surfactant complexes: Decomposition, mutagenicity and soil leaching studies“, *Environmental Science and Technology*, 16:566-571.
- Kaye, S.M. (1980)  
*Encyclopedia of Explosives and Related Items, Volume 9*, U.S. Army Armament Research and Development Command, Large Caliber Weapon Systems Laboratory, Dover, New Jersey.
- Keller, H.B. (1970)  
“A new difference scheme for parabolic problems“ in J. Bramble (ed.), *Numerical Solution of Partial-Differential Equations*, Vol. II, Academic Press, New York.
- Kenaga, E.E., and C.A.I. Goring (1980)  
“Relationship between Water Solubility, Soil Sorption, Octanol-Water Partitioning, and Concentration of Chemicals in Biota“, in J. G. Eaton, P.R. Parrish and A.C. Hendricks (eds.), *Aquatic Toxicology*, ASTM STP 707, American Society for Testing and Materials, pp. 78-115.
- Kjellstrom, A.H. and L.M. Sarholm (2000)  
“Analysis of TNT and related compounds in vapor and solid phase in different types of soil“, in A.C. Dubey, J.F. Harvey, J.T. Broach and R.E. Dugan (eds), *Proceedings of the SPIE 14<sup>th</sup> Annual International Symposium on Aerospace/Defense Sensing, Simulation and Controls, Detection and Remediation Technologies for Mines and Minelike Targets V, April 24-28, 2000*.
- Leggett, D.C., T.F. Jenkins and R.P. Murrmann (1977)  
*Composition of Vapors Evolved from Military TNT as Influenced by Temperature, Solid Composition, Age, and Source*, U.S. Army Corps of Engineers, Cold Regions Research and Engineering Laboratory, SR 77-16/AD A040632.
- Leggett, D.C., T.F. Jenkins, A. Hogan, T.A. Ranney and P.H. Miyares (2000)  
*External Contamination on Landmines by Organic Nitro-Compounds. U.S. Army Engineer Research and Development Center - Cold Regions Research and Engineering Laboratory*, ERDC-CRREL Technical Report TR-00-2, Hanover, NH., March.
- Leggett, D.C., J.H. Cragin, T.F. Jenkins and T.A. Ranney (2001)  
*Release of Explosive-Related Vapors from Landmines*, U.S. Army Engineer Research and Development Center - Cold Regions Research and Engineering Laboratory, ERDC-CRREL Technical Report TR-01-6, Hanover, NH., February.
- Leggett, D.C. and J.H. Cragin (2002)  
*Diffusion and Flux of Explosive-Related Compounds in Plastic Mine Surrogates*, U.S. Army Engineer Research and Development Center - Cold Regions Research and Engineering Laboratory, ERDC-CRREL Technical Report ERDC-TR-33, Hanover, NH.
- Lenchitz, C., and R.W. Velicky (1970)  
“Vapor Pressure and Heat of Sublimation of Three Nitrotoluenes“, *Journal of Chemical & Engineering Data*, 15(3):401-403.
- Lyman, W.J., W.F. Reehl and D.H. Rosenblatt (1990)  
*Handbook of Chemical Property Estimation Methods, Environmental Behavior of Organic Compounds*, American Chemical Society, Washington D.C.
- Mark, H.F., and J.I. Kroschwitz (1985)  
*Encyclopedia of polymer science and technology*, John Wiley & Sons Inc.
- Maskarinec, M.P., C.K. Bayne, L.H. Johnson, S.K. Holladay, R.A. Jenkins and B.A. Tompkins (1991)  
*Stability of explosives in environmental water and soil samples*, Oak Ridge National Laboratory Report ORNL/TM-11770, Oak Ridge, Tennessee, 37831.

- Mayer, R., J. Letey and W.J. Farmer (1974)  
“Models for predicting volatilization of soil-incorporated pesticides”, *Soil Sciences Society of America Proc.*, 38:563-568.
- Millington, R.J., and J.M. Quirk (1961)  
“Permeability of porous solids”, *Transactions of the Faraday Society*, 57:1200-1207.
- Miyares, P.H., and T.F. Jenkins (2000)  
*Estimating the Half-Lives of Key Components of the Chemical Vapor Signature of Land Mines*, U.S. Army Engineer Research and Development Center, Cold Regions Research and Engineering Laboratory, Technical Report ERDC/CRREL TR-00-17, September.
- Murrmann, R.P., Y. and Nakano (1971)  
*Influence of Soil on Detection of Buried Explosives and Tunnels by Trace Gas Analysis*, Report No: RR 288/AD 727667, U.S. Army Corps of Engineers, Cold Regions Research and Engineering Laboratory.
- Murrmann, R.P., T.F. Jenkins and D.C. Leggett (1971)  
*Composition and Mass Spectra of Impurities in Military Grade TNT Vapor*, U.S. Army Cold Regions Research and Engineering Laboratory, Special Report 158, Hanover, NH.
- Ong, S.K., and L.W. Lion (1991a)  
“Mechanisms for trichloroethylene vapor sorption onto soil minerals”, *Journal of Environmental Quality*, 20:180-188.
- \_\_\_\_\_ (1991b)  
“Effects of soil properties and moisture on the sorption of trichloroethylene vapor”, *Water Resources*, 25:29-36.
- Ong, S.K., T.B. Culver, L.W. Lion and C.A. Shoemaker (1992)  
“Effects of soil moisture and physical-chemical properties of organic pollutants on vapor-phase transport in the vadose zone”, *Journal of Contaminant Hydrology*, 11:273-290.
- O'Reilly, W.F., T.F. Jenkins, R.P. Murrman, D.C. Leggett and R. Barrierra (1973)  
*Exploratory Analysis of Vapor Impurities From TNT, RDX and Composition B*, U.S. Army Cold Regions Research and Engineering Laboratory, Special Report 194, Hanover, NH, October.
- Pella, P.A. (1977)  
“Measurement of the vapor pressures of TNT, 2,4-DNT, 2,6-DNT and EGDN”, *Journal of Chemical Thermodynamics*, 9:301-305.
- Pennington, J.C., and W.H. Patrick (1990)  
“Adsorption and Desorption of 2,4,6-Trinitrotoluene by Soils”, *Journal of Environmental Quality*, 19:559-567.
- Pennington, J.C., P.H. Miyares, D.B. Ringelberg, M. Zakikhani, C.M. Reynolds, D. Felt, R.B. Coffin, D. Gunnison, L. Cifuentes, H. L. Fredrickson and T. F. Jenkins (1999)  
*Natural Attenuation of Explosives in Soil and Water Systems at Department of Defense Sites: Final Report*, U.S. Army Corps of Engineers, Technical Report SERDP-99-1, July.
- Pennington, J.C., C.A. Hayes, S.L. Yost, P.Miyares and T. Jenkins (1999)  
*Partitioning Coefficients on Fort Leonard Wood Soils*, Draft Report, U.S. Army Corps of Engineers, Waterways Experiment Station, 1 September 1.
- Petersen, L.W., D.E. Rolston, P. Moldrop and T. Yamaguchi (1994)  
“Volatile Organic Vapor Diffusion and Adsorption in Soils”, *Journal of Environmental Quality*, 23:799-805.

- Petersen, L.W., P. Moldrup, Y.H. El-Farhan, O.H. Jacobsen, T. Yamaguchi and D.E. Rolston (1995)  
“The Effect of Moisture and Soil Texture on the Adsorption of Organic Vapors”, *Journal of Environmental Quality*, 24:752-759.
- Petersen, L.W., Y.H. El-Farhan, P. Moldrup, D.E. Rolston and T. Yamaguchi (1996)  
“Transient Diffusion, Adsorption and Emission of Volatile Organic Vapors in Soils with Fluctuating Low Water Contents”, *Journal of Environmental Quality*, 25:1054-1063.
- Peterson, M.S., L.W. Lion and C.A. Shoemaker (1988)  
“Influence of Vapor-Phase Sorption and Diffusion on the Fate of Trichloroethylene in an Unsaturated Aquifer System”, *Environmental Science & Technology*, Vol. 22, 5:571-578.
- Phelan, J.M., and J.L. Barnett (2001a)  
*Phase Partitioning of TNT and DNT in Soils*, Sandia National Laboratories Report SAND2001-0310, Albuquerque, New Mexico, February.
- \_\_\_\_\_ (2001)  
“Solubility of 2,4-Dinitrotoluene and 2,4,6-Trinitrotoluene in Water”, *Journal of Chemical and Engineering Data*, March/April.
- \_\_\_\_\_ (2002)  
“Chemical Sensing Thresholds for Mine Detection Dogs” in A.C. Dubey, J.F. Harvey and J.T. Broach (eds), *Proceedings of the SPIE 16<sup>th</sup> Annual International Symposium on Aerospace/Defense Sensing, Simulation and Controls, Detection and Remediation Technologies for Mines and Minelike Targets VII, April 1-5, 2002*, Orlando, FL.
- \_\_\_\_\_ (forthcoming)  
*Degradation of Post-Blast Residue from Antipersonnel Landmines*, Sandia National Laboratories Report.
- Phelan, J.M., J.L. Barnett and P.J. Rodacy (2000a)  
*Post-Blast Residue from Antipersonnel Landmines*, SAND2000-1651, Sandia National Laboratories, Albuquerque, NM, July.
- Phelan, J.M., and S.W. Webb (1997)  
*Environmental Fate and Transport of Chemical Signatures from Buried Landmines-Screening Model Formulation and Initial Simulations*, Sandia National Laboratories, SAND97-1426, June.
- \_\_\_\_\_ (1998a)  
“Chemical Detection of Buried Landmines”, in *Proceeding of the 3<sup>rd</sup> International Symposium on Technology and the Mine Problem, April 6-9, 1998*, Mine Warfare Association.
- \_\_\_\_\_ (1998b)  
“Simulation of the Environmental Fate and Transport of Chemical Signatures from Buried Landmines”, in *Proceedings of the SPIE 12<sup>th</sup> Annual Conference on Detection and Remediation Technologies for Mines and Minelike Targets III, Orlando, FL, April 13-17, 1998*.
- \_\_\_\_\_ (1999)  
“Chemical Soil Physics Phenomena for Chemical Sensing of Buried UXO”, in *Proceedings of UXO Forum, May 25-27, 1999*, Department of Defense Explosive Safety Board and United States Army Environmental Center.
- Phelan, J.M., M. Gozdor, S.W. Webb and M. Cal (2000)  
“Laboratory Data and Model Comparisons of the Transport of Chemical

- Signatures From Buried Landmines/UXO” in A.C. Dubey, J.F. Harvey, J.T. Broach and R.E. Dugan (eds), *Proceedings of the SPIE 14<sup>th</sup> Annual International Symposium on Aerospace/Defense Sensing, Simulation and Controls, Detection and Remediation Technologies for Mines and Minelike Targets V, April 24-28, 2000*.
- Phelan, J.M., P.J. Rodacy and J.L. Barnett (2001)  
*Explosive Chemical Signatures from Military Ordnance*, Sandia National Laboratories Report SAND2001-0755, Albuquerque, New Mexico, April.
- Phelan, J.M., S.W. Webb, M. Gozdor, M. Cal and J.L. Barnett (2001a)  
“Effect of Wetting and Drying on DNT Vapor Flux – Laboratory Data and T2TNT Model Comparisons” in A.C. Dubey, J.F. Harvey, J.T. Broach and V. George (eds), *Proceedings of the SPIE 15<sup>th</sup> Annual International Symposium on Aerospace/Defense Sensing, Simulation and Controls, Detection and Remediation Technologies for Mines and Minelike Targets VI, April 16-20, 2000*, Orlando, FL.
- Pruess, K. (1987)  
*TOUGH User’s Guide*, NUREG/CR-4645, SAND86-7104, LBL-20700, US Nuclear Regulatory Commission.
- \_\_\_\_ (1991)  
*TOUGH2 - A General-Purpose Numerical Simulator for Multiphase Fluid and Heat Flow*, LBL-29400, Lawrence Berkeley Laboratory.
- \_\_\_\_ (1995)  
*Proceedings of the TOUGH Workshop ’95*, Berkeley, CA. LBL-32700, Lawrence Berkeley Laboratory, 20-22 March.
- Ro, K. S., A. Venugopal, D.D. Adrian, W.D. Constant, K. Qaisi, K.T. Valsaraj, L.J. Thibodeaux and D. Roy (1996)  
“Solubility of 2,4,6-Trinitrotoluene (TNT) in Water”, *Journal of Chemical and Engineering Data*, 41:758-761.
- Rosenblatt, D.H., E.P. Burrows, W.R. Mitchell and D.L. Parmer (1991)  
“Organic Explosives and Related Compounds”, in O. Hutzinger (ed.), *The Handbook of Environmental Chemistry* Volume 3, Part G.; Springer-Verlag, New York.
- Sawyer, C.N., P.L. McCarty and G. F. Parkin (1994)  
*Chemistry for Environmental Engineering*, Fourth Edition, McGraw-Hill, Inc.
- Schroeder, P.R., C.M. Lloyd and P.A. Zappi (1994)  
*The Hydrological Evaluation of Landfill Performance (HELP) Model User’s Guide for Version 3*, EPA/600/R-94/168a, U.S. Environmental Protection Agency, Risk Reduction Engineering Laboratory, Cincinnati, Ohio.
- Schroeder, P.R., T.S. Dozier, P.A. Zappi, B.M. McEnroe, J.W. Sjostrom and R.L. Peyton (1994b)  
*The Hydrological Evaluation of Landfill Performance (HELP) Model: Engineering Documentation for Version 3*, EPA/600-R-94/168b, U.S. Environmental Protection Agency, Risk Reduction Engineering Laboratory, Cincinnati, Ohio.
- Settles, G. S., and D. A. Kester (2001)  
“Aerodynamic sampling for landmine trace detection” in A.C. Dubey, J. F. Harvey, J. T. Broach and V. George (eds), *Proceedings of SPIE Vol 4394, Detection and Remediation Technologies for Mines and Minelike Targets VI*.
- Spain, J.C. (1995)  
“Biodegradation of Nitroaromatic Compounds”, *Annual Review of Microbiology*, 49:523-555.



- Spain, J.C., J. B. Hughes and H. Knackmuss (eds) (2000)  
*Biodegradation of Nitroaromatic Compounds and Explosives*, Lewis Publishers, CRC Press, Boca Raton, Florida.
- Spanggord, R.J., W.R. Mabey, T. Mill, T.W. Chou, J.H. Smith, S. Less and D. Robert (1983)  
*Environmental Fate Studies on Certain Munitions Wastewater Constituents*, LSU-7934, AD-A138550, SRI International, Menlo Park, CA.
- Spangler, G.E. (1974)  
*Physical Model for the Subterranean Movement of Explosive Vapors from Mines*, Report MERADCOM-R-2095, U.S. Army Mobility Equipment Research and Development Center, Fort Belvoir, Virginia.
- \_\_\_\_\_ (1975)  
*Measurements on the Availability of TNT Vapor from Antitank Mines*, Report MERADCOM-R-2159, U.S. Army Mobility Equipment Research and Development Center, Fort Belvoir, Virginia.
- Spencer, W.F., and M.M. Cliath (1973)  
“Pesticide volatilization as related to water loss from soil”, *Journal of Environmental Quality*, 2:284-289.
- Spencer, W.F., M.M. Cliath, W.A. Jury and L.-Z. Zhang (1988)  
“Volatilization of Organic Chemicals from Soil as Related to Their Henry’s Law Constants”, *Journal of Environmental Quality*, 17:504-509.
- Stephen, H., and T. Stephen (1963)  
*Solubilities of Inorganic and Organic Compounds*, Vol.1, Part 1, Macmillian Co., New York.
- Taylor, C.A., and W.H. Rinkenbach (1923)  
“The Solubility of Trinitrotoluene in Organic Solvents”, *Journal of American Chemical Society*, 45:44-59.
- Tucker, W.A., E.V. Dose, G.J. Gensheimer, R.E. Hall, C.D. Pollman and D.H. Powell (1985)  
*Evaluation of critical parameters affecting contaminant migration through soils*, Final Report for the U.S. Army Toxic and Hazardous Materials Agency, ESE, Gainesville, FL.
- U.S. Army (1971)  
*Engineering Design Handbook: Explosives Series. Properties of Explosives of Military Interest*, AMPC 706-177, Headquarters, U.S. Army Material Command, January.
- U.S. Environmental Protection Agency (1992)  
*SW846, Chapter One – Quality Control, Revision 1*, GPO, Washington D.C.
- Urbanski, T. (1964)  
*Chemistry and Technology of Explosives*, Vol I, Macmillian Co., New York.
- Verschuere, K. (1983)  
*Handbook of Environmental Data on Organic Chemicals*, 2<sup>nd</sup> ed., Van Nostrand Reinhold Co., New York.
- Walsh, M.E., and T.A. Ranney (1999)  
*Determination of Nitroaromatic, Nitramine, and Nitrate Ester Explosives in Soils Using GC-ECD*, Special Report 99-12, U.S. Army Corps of Engineers, Cold Regions Research and Engineering Laboratory, August.
- Webb, S.W. (1996)  
*Gas Phase Diffusion in Porous Media — Evaluation of an Advective-Dispersive Formulation and the Dusty-Gas Model Including Comparison to Data for Binary Mixtures*, SAND96-1197, Sandia National Laboratories.



- Webb, S.W. (2000)  
 “A simple extension of two-phase characteristic curves to include the dry region”,  
*Water Resources Research*, 36(6):1425-1430.
- Webb, S.W., and J.M. Phelan (2000)  
 “Effect of Diurnal and Seasonal Weather Variations on the Chemical Signatures  
 from Buried Landmines/UXO”, in *Proceedings of the SPIE 14<sup>th</sup> Annual International  
 Symposium on Aerospace/Defense Sensing, Simulation and Controls, Detection and  
 Remediation Technologies for Mines and Minelike Targets V, April 24-28, 2000.*
- Webb, S.W., S.A. Finsterle, K. Pruess and J.M. Phelan (1998)  
*Prediction of the TNT Signature from Buried Landmines*, Proceedings of the TOUGH  
 '98 Workshop, Berkeley, CA.
- Webb, S.W., K. Pruess, J. M. Phelan and S. Finsterle (1999)  
 “Development of a Mechanistic Model for the Movement of Chemical Signatures  
 from Buried Landmines/UXO”, in *Proceedings of the SPIE 14<sup>th</sup> Annual International  
 Symposium on Aerospace/Defense Sensing, Simulation and Controls, Detection and  
 Remediation Technologies for Mines and Minelike Targets IV, April 5-9, 1999.*
- Xue, S.K., I.K. Iskandar and H.M. Selim (1995)  
 “Adsorption-Desorption of 2,4,6-Trinitrotoluene and Hexahydro-1,3,5-Trinitro-  
 1,3,5-Triazine in Soils”, *Soil Science*, 160(5).

## List of figures

- Figure 1. Chemical structures for compounds important to landmine chemical sensing
- Figure 2. PMA-1A landmine hinged box style and wax paper coating
- Figure 3. PMA-2 antipersonnel landmine and fuze
- Figure 4. Base of TMA 5 showing holes
- Figure 5. Coating on TMA-5 main charge explosive
- Figure 6. Diffusion coefficients for chemical penetrants in rubber and PVC
- Figure 7. TNT leakage rate dependence into air or water
- Figure 8. Resident concentration of TNT in various plastics and landmine case materials
- Figure 9. Whole landmine flux tests in soil
- Figure 10. Diffusive flux in dry or wet soil
- Figure 11. Vapor density vs. temperature
- Figure 12. Water solubility vs. temperature
- Figure 13. DNT and TNT Henry's Law Constant as a function of temperature
- Figure 14. DNT and TNT soil-vapor partitioning coefficient vs. soil moisture content
- Figure 15. Soil solid and liquid phase mass fractions
- Figure 16. Soil vapour mass fraction
- Figure 17. Effect of  $K_d$  on TNT solid and liquid mass fraction
- Figure 18. Effect of  $K_d$  on vapour mass fraction
- Figure 19. Effect of temperature on TNT vapour mass fraction
- Figure 20. 3-D plot of post-blast residue degradation half-lives as a function of soil moisture and temperature
- Figure 21. TNT vapor, solute and effective diffusivity (Phelan and Webb, 1997)
- Figure 22. Effective diffusivity for TNT, DNT and DNB with soil saturation
- Figure 23. Vapour transport study results
- Figure 24. Depiction of chemical concentration variation including boundary layer

- Figure 25. Winter soil and landmine temperatures  
Figure 26. Summer soil and landmine temperatures  
Figure 27. Complex interdependencies affecting landmine signature chemicals in soil  
Figure 28. Boundary layer thickness  
Figure 29. Laboratory soil column test apparatus.  
Figure 30. Data model comparisons — effect of  $K_d$  value  
Figure 31. T2TNT data-model comparisons  
Figure 32. Diurnal variation of various parameters for the period 50-60 days  
Figure 33. Seasonal variation of surface liquid- and gas-phase concentrations  
Figure 34. Spatial distribution of 2,4-DNT (ng/g) in surface soils near TMA-5 and PMA1A  
Figure 35. TNT soil headspace concentrations as a function of soil moisture content  
Figure 36. DNT soil headspace concentrations as a function of soil moisture content  
Figure 37. Jar in testing station  
Figure 38. MEDDS vapour sample presentation method  
Figure 39. MEDDS filter soil vapour generator  
Figure 40. REST sample presentation method  
Figure 41. Initial testing strategy

## List of tables

- Table 1. Scientific notation  
Table 2. Water and soil concentration units  
Table 3. “Parts per” notation  
Table 4. Number of molecules in soil, water and air samples  
Table 5. Concentration of 1 molecule of TNT in a sample of soil, water and air  
Table 6. Impurities present in TNT by continuous nitration and purification  
Table 7. Solid and vapour phase composition of Military Grade TNT  
Table 8. Equilibrium headspace vapour concentrations above Military Grade TNT  
Table 9. Plastics used in landmines  
Table 10. Landmine flux into air (20°C), ng/mine per day  
Table 11. Comparison of mine flux into air and water at 22°C (ng/mine per day)  
Table 12. Whole landmine flux tests results (mg/day)  
Table 13. TNT phase partitioning estimation spreadsheet  
Table 14. Parent and degradation by-products of TNT, DNT and DNB  
Table 15. Degradation half-lives for wet soils  
Table 16. Post-blast residue TNT degradation half-life (days)  
Table 17. Synthetic soil residue degradation half-life (days)  
Table 18. Estimated chemical properties  
Table 19. Sensitivity analysis summary  
Table 20. Soil residues from Bosnia  
Table 21. Summary of surface soil residues (ng/g) collected near mines in August 1998 and April, July, November 1999  
Table 22. Estimated vapour concentrations in the air boundary layer from surface soils residue data and  $K_s/a$  values  
Table 23. Decade dilution soil residues (ng/g)



## Afterword

# Animal detection in the future

*Håvard Bach*

**I**n the early 1990s, we were made aware of the global landmine crisis. At the time, it was clear that only a fast and efficient demining process could address this problem — and that the use of dogs to sniff out landmines was particularly promising. Mine dog detection has since grown to become a large segment of the humanitarian demining industry, but not without some difficulties. Most of the early MDD programmes were established by ex-military/police trainers who, while having considerable experience as dog trainers and handlers, had little understanding of the landmine problem. Many opinions and disagreements were voiced, practice was strongly individualistic, and there was little industry coherence (see Chapter 2). Moreover, the fundamental properties of vapour sensing for explosives (operational, physiological, chemical) had previously received little research attention. One consequence was that dogs missed mines with no clear explanation, and practitioners had a limited ability to respond to the problem.

The post-war situation in Bosnia and Herzegovina in 1997 and 1998 had a major impact on the way we use dogs today. Bosnia and Herzegovina became a Klondike for demining organisations, some of which took a gamble by using poorly-trained dogs in exchange for higher profit. Some companies further claimed a much higher productivity than their NGO and commercial competitors. Perhaps surprisingly, the quality of the product was never officially questioned during the early stage of the operation. This situation changed when Bosnia and Herzegovina became the first country to introduce national



*The initial test site in Bosnia. When failing tests here, demining organisations complained about the high clay content preventing dogs from finding the mines. Yet dogs were used operationally in similar areas in Bosnia.*

testing of mine dogs, a painful process causing considerable mud-slinging between NGOs, demining organisations, and the national Mine Action Centre (MAC). Demining organisations outshone each other in making excuses for the appalling results. Their explanations were unconvincing. However, the MAC became the scapegoat and it was claimed that the test procedures were unfair. Yet some demining organisations managed to pass the test with most of their dogs. Nevertheless, the overall credibility of MDD had been significantly affected.

Consequently, the GICHD launched a study of mine dog detection based on a desire to improve overall MDD, define its limitations, and improve its credibility. In 2003, recovery has been partially achieved and MDD has improved. There is agreement on the basic principles of training and use of dogs. We largely understand the chemistry of vapour transportation in soil, and how environmental effects, including soil properties and weather, affect this process (Chapter 5). Despite all this, we are far from understanding the full potential and limitations of MDD. The line between success and failure is fine and blurred, and demining organisations keep crossing this line thus leaving mines behind. International standards<sup>1</sup> for demining have been established, and are high, although not all MDD operations manage to live up to these standards. Recent reports reveal that the number of mines left behind by some dog teams is much higher than is acceptable (if there is any sense in which any mine being left behind can be considered acceptable). *An ongoing and systematic application of research and operational improvement will improve this situation and make MDD faster, safer and more reliable than is the case today.*

In the rest of this chapter, I discuss relevant issues requiring resolution or thought in order to achieve this improvement, and offer some comments about the way forward.

## Dogs versus alternative vapour technology

A successful demining technology is one that can speed up a demining process safely and reliably with a lower than proportional increase in costs. One alternative to dogs that has undergone significant development, is the use of another animal system (e.g. rats, see Chapter 4, Part 2). Artificial vapour detection also has the potential to compete with (or be used in conjunction with) animals. However, dogs (and rats) are still far better vapour detectors than any currently available technology. Furthermore, dogs and rats are sensitive to many different scents concurrently, a property that has proven difficult to replicate artificially. Artificial vapour detection of landmines therefore presents a real challenge, which is unlikely to be overcome by researchers in the near future. Even if the technology achieves the success levels of animals, it will take additional time for operational prototypes to be developed and final products to be absorbed by the industry.

Solving the landmine problem is a long process, and research into artificial noses may still pay off. That said, the current discrepancy between the sensors of animals and machines suggests that mine dogs and perhaps rats will maintain their role as leading vapour sensors for landmine detection in the foreseeable future. However, increased focus on quality of work (reflected in, and led by, IMAS) will require ongoing improvements in both the understanding of chemical and biological processes and the perfecting of training and using dogs and rats in the field.

1. IMAS ([www.mineactionstandards.org](http://www.mineactionstandards.org)).

## Alternative sensor technology

Vast sums have been spent on the development of more efficient sensor technologies. Many detection principles have been studied by hundreds of research organisations. The results, however, are discouraging, as there has been no real breakthrough. Furthermore, the demining sector is small and almost insignificant: it is therefore questionable whether the market is big enough to justify the costs of developing and mass-producing seemingly promising new technologies for humanitarian demining. More likely is that humanitarian demining will profit from spin-off effects of military or security requirements, rather than becoming a real market in itself. Moreover the demining industry tends to resist the introduction of new technologies for many reasons, one of which is that high-tech equipment is considered less appropriate for programmes aiming to develop and sustain local demining capacity. While it can be argued that this view is unnecessarily pessimistic, targeted improvement of current technology, such as MDD, is likely to have a greater positive impact on the speed and quality of humanitarian demining during the next 20 years than is research into new technologies.

## Future role of the GICHD MDD project

The GICHD MDD study was implemented as a series of independent but closely interlinked sub-studies. The aim was to develop international standards and guidelines, including conducting the necessary research to understand strengths and limitations. The study has, however, evolved into something more. It now provides a focal point and a platform for cooperation between research and practice. Without such a focus, it seems likely that MDD will slide back to what it was before: a fractured industry flavoured by discrepancy of opinion and practice (Chapter 3). The GICHD intends to maintain its research coordination role and to provide the MDD industry with an independent and impartial focal point for exchanging information for as long as is needed and funding can be obtained. The aims of the project will change over time, as a direct product of current and future research results and practical experience. Below are some current and planned areas of focus for the GICHD during the next two years.

### *Disseminating information*

There will be an ongoing focus on dissemination of research products to the MDD community. As research chapters are completed, publications will be made and distributed. However, research reports alone may not be the best way to disseminate information. Complex issues, such as the vapour transportation process (Chapter 5) or training methodology (Chapter 1), are hard to explain in writing in a way that is clear to operational staff. For some, it may be difficult to relate written information to field or training situations. It is therefore important to use a variety of presentation approaches. Video films, as a supplement to written reports, should increase the understanding of facts and recommendations from research, and could additionally stimulate use of research reports as reference material. Currently, the GICHD is producing four video films as a pilot project, three of which will complement this book. Filming is planned to take place in Afghanistan, Angola, Bosnia and Herzegovina, Cambodia, Croatia, Norway, South Africa, and Tanzania. The final product will be completed in late 2003.



### *Environmental factors*

Although vapour transportation in soil is reasonably well understood, there is a long way to go. Vapour availability at ground level largely depends on the quality of target scent emanating from the landmine. A well-sealed landmine may not be detected by a dog under perfect conditions simply because too little scent is transported to the surface. To determine the availability of vapour at the surface, it is necessary to take flux rate (leakage) from landmines into account. It is known that some mines are easier to detect than others, but very little research has been undertaken to determine the flux rate from different landmines. A landmine leakage library could be as valuable to an MDD organisation in the future as technical data about metal content in landmines is for a manual mine clearance organisation today. Understanding of the relationship between flux rate, target scent at surface level, and the effects of weather and soil properties on migration of vapour through the soil, is essential to be able to predict whether the detection potential is above or below detection benchmarks for different equipment — including dogs and rats. Defining the limits of detection will assist in the understanding of the optimal deployment of animal detector systems and productivity, and safety should also be improved.

With the above thoughts in mind, the GICHD has recently expanded its partnership with Sandia National Laboratory. Two new projects have been designed: one will address flux rate from landmines, the other will enable computerised simulation of the vapour transportation process. Results from these two projects are expected in 2003.

### *Breeds*

It has always been difficult to find suitable dogs for training as mine detection dogs within the currently used breeds. The 11 September 2001 tragedy made the situation worse because it triggered an increased worldwide requirement for dogs to sniff out explosives at airports. The demand for detection dogs now far exceeds the supply. In 2001, the GICHD published a report analysing positive and negative properties of dog breeds for mine detection. One of the conclusions was that there are probably breeds better suited to mine detection work than the currently used breeds. One suggested alternative was the Swedish drever, a scent hound bred for hunting. It is of course unlikely that an experimental breed would be adopted for use by a necessarily conservative industry with limited financial resources. The GICHD has thus purchased and donated eight drevers to four demining organisations, commercial and non-commercial, for experimental training and comparison with more traditional breeds. The end result could be that we will have more and better breeds to choose from in the future. The GICHD will continue to facilitate this project, including publishing results from the experimental training of drevers. Breeding and training of MDDs is however a slow process. It will inevitably take several years before we have enough experience to draw conclusions.

### *Rats — a realistic alternative*

Rats have many advantages compared to dogs (Chapter 4, Part 2). They are easier and faster to breed and can be trained from about six weeks of age. Some rats, such as the African giant pouched rat, have a life span of up to seven or eight years. Rats also exhibit repetitive search behaviour, a much-desired quality in a mine detection animal.

Rats are small, easy to accommodate and transport and as wild animals should be more resilient to local environments than dogs, especially in tropical climates. Rats behave differently to dogs and this reflects in the way rats are trained and used. For example, in contrast to traditional ways of training and using dogs there is almost no rat/handler dependency. Communication between the handler and the dog is vital for successful MDD, at least in most programmes using dogs. Elimination of dependency between the animal and the handler will largely eliminate miscommunication errors, which is one of the most common reasons for missed landmines.



*Rat analysing REST filters (the filters are placed below the walking track).*

The APOPO rats project has shown promising results and the GICHD has supported this interesting research programme during the last two years. APOPO has undertaken experimental training of rats in different configurations and with different rat species. The African giant pouched rat has shown the most promising results.

APOPO trains rats for direct and indirect mine detection. Although rats have shown good potential for direct detection, the use of rats in a REST concept (indirect detection) may be a more promising application. The research project has now reached a stage where field search and REST rats will soon be tested operationally. Important in this process is proper documentation and an effective validation. However, even if all these challenges are addressed, it is not automatic that rats will be taken into use. The demining industry is small and breaks with the principles of a free



*Rat searching for landmines.*

market economy. Economic decisions on demining are often based on political agendas. Donors may fund their favourite NGOs rather than those with the highest productivity. And the use of technology can often relate to where the technology has been developed, with governments only funding programmes if they use machinery or detectors from their own country. Also, the selection of technology may be based as much on tradition and political influence as on a search for the optimal system. Clearly, six years of research would be a waste if the rats were not adopted in the field. The challenge, as with all new demining technology, is to ensure that research is accompanied by the development of practical procedures and equipment and field testing on an operational scale. Prejudices about rats due to their reputation for harbouring disease and bringing death must also be addressed. If rats are accepted by the industry, it will be necessary to establish a capacity to breed, train and introduce rats to demining organisations: rats are not available for purchase in the same way as dogs. Clearly, if rats are only marginally used, it will be difficult to defend and fund a comprehensive support centre. But without such a centre, it is unlikely that demining organisations will adopt and maintain programmes using rats.

### *Improving operational procedures*

We have so far prioritised studies of environmental factors and Remote Explosive Scent Tracing (REST) at the cost of studies on the operational use of dogs in the field. Dogs are used differently, and there are pros and cons with different operational procedures. Intensive analysis of the functional areas of MDD field operations will identify the links between behaviour, routine and efficiency of work, potentially leading to optimisation of the use of dogs. This is a more time-consuming but effective alternative to traditional evaluation methods which tend to oversee field operations without making in-depth analysis of procedures.

There will therefore be a stronger emphasis on studies of MDD operations in the future. A series of case studies will eventually be available for comparison, some of which have already been completed. Some of the results show surprising dependencies between speed and applied procedures, dependencies that the demining organisations themselves had not yet observed or recognised.

### *Remote Explosive Scent Tracing*



*Filter analysis in Angola.*

In contrast to common opinion, the most important challenge in humanitarian demining is usually to determine where landmines have *not* been laid. Much greater areas are typically suspected as mined than those actually mined. Area reduction is often 90 per cent of a demining operation and has a more significant immediate impact on the community than clearance. REST is an example of a system that should work fast to define mine-free sectors of land. If REST could be applied for area reduction, vast areas of land could

be released more quickly and at a much lower price than using any other demining technology. REST has already been used as a rapid road verification tool (Chapter 4, Part 1). The system is, however, poorly understood and little is known about its limitations, particularly in relation to how best to train and use REST dogs (Chapter 2, Part 2). It is thus difficult to use REST for area reduction today. The use of REST can best be illustrated by describing it as a way of capturing images of large areas rather than small areas, such as those covered by a search head of a metal detector. This allows higher sampling speed, which is key to an efficient demining technology.

This book has described the various elements of a REST process, including one method for training REST dogs. Dogs can easily be trained to detect the correct substance and to sniff out contaminated (positive) filters, but the pitfalls are many. Small and seemingly trifling errors applied during training can make a difference between success and complete failure. Dogs will typically pick up any possible clue that could help indicate whether filters are positive or negative. Without full understanding of these clues, dogs will fool us by applying clue-based detection rather than real detection of scent. In this context a clue means an aid that the animal uses to detect what it thinks we want it to detect. A clue can be a scent, the lack of scent, a signal from the handler or simply a tendency towards non-random placement of positive filters in an analysis set-up. We have only recently become aware of some of these problems, and need to understand them better before the REST system can be fully applied.

REST is prioritised by the GICHD because of the potentially high impact of this technology in the future. REST could become one of the most effective area reduction tools provided that its strengths and limitations have been fully defined. The various elements of REST also need to be optimised, to increase its potential use and credibility. Current and future activities involve the following components:

#### **Filter technology and sampling equipment**

Key properties of a REST filter are the ability to trap the highest possible concentration of TNT molecules during sampling and to release a high percentage of the same molecules during analysis. The current filter cartridges (used by Mechem, NPA and NOKSH) may not possess these properties or could be improved. Another issue is the ability to absorb dust during sampling. Dust contains much higher concentrations of TNT molecules than air at ground level. Filters capable of trapping more dust without clogging will therefore increase the overall mass of TNT in the filter. The Swedish Defence Research Agency has been asked to investigate the positive and negative properties of the currently used filter cartridges and to develop improved filters and sampling equipment. This is an ongoing process and prototypes are soon to be presented.

#### **Area reduction application**

An important weakness of REST is that we do not know the size of the detectable scent plume above landmines. The plume size will depend on many factors, including type of mine, soil properties, environmental factors, filter material, suction pressure and sampling technique. Practical field experience suggests that REST sampling will pick up mines from a minimum distance of eight metres. The reliability of this estimate is, however, unknown and it is necessary to fully determine variations in the detectable plume if the aim is to use REST for area reduction. NPA-Angola has been asked to manage a test project and undertake repeated sampling and analysis in a test field, which differs from most other test fields in that the minimum distance between landmines is 35 metres to avoid cross contamination. The sampling and analysis



involves ten sampling sequences over a period of 12 months. Each sampling sequence will involve the use of 1,600 filter cartridges. The results will be used to determine reliable detection distances for mines, which will help to define the optimum size of sampling area for REST.

#### REST validation, Bosnia

The REST dogs trained by NOKSH (Chapter 2, Part 2) for the GICHD study on REST are now being used as verification tools for further research. A short-term test and confirmation programme has been designed in collaboration with BHMAC, NPA-Bosnia, and NOKSH to determine whether the dogs can find mines reliably in Bosnia. If this proves to be the case, BHMAC and NPA-Bosnia will consider using the REST system in Bosnia in the future. Preliminary results from this project indicate good results. However, it is also clear that detectability of mines is linked to weather patterns at the time of sampling, and weather could influence reliability. The NOKSH dogs will also be valuable assets for the GICHD when carrying out trials on new filter cartridges and for quality control of filters from test projects in Angola and Tanzania.

#### The use of rats

It is now clear that rats can be trained to detect landmines in the field (Chapter 4, Section 2). As APOPO have argued, the economics of training and using rats operationally could be lower than for dogs. However, there is need for a proper test and validation to justify such claims, and to field test the use of rats in minefields. There is also need for further work on the potential of rats as REST detectors. The work of APOPO is helping to identify undesired clues that animal detectors will use to help detect contaminated filters. Thus APOPO will potentially help to identify essential improvements for REST dog programmes.

#### Operational sampling concept, area reduction

If it is proven that REST has potential for area reduction, the next step is to develop safe and efficient sampling methods. To search roads, REST sampling teams walk in the tracks created by heavy mine-proof vehicles. This method will have less application outside typical road scenarios where vegetation could prevent the sampling team from following the tracks, and tripwires would be a real risk. It is clear that new sampling techniques must be developed. This work, has, however been postponed in anticipation of the results from research and tests on REST area reduction application.



*Current way of sampling is probably inadequate for area reduction.*

#### Establishing REST testing facilities

There are two possibilities: one is to establish many REST analysis facilities in mine-affected countries; the other is to centralise the analysis service in a few locations. The latter is probably the easier and less costly approach, and the GICHD is exploring the possibility of establishing centralised REST testing facilities in three locations (Bosnia and Herzegovina, Southeast Asia, Southern Africa). It remains to be seen whether the cost and logistics of shipping large numbers of filters are viable.

### *International standards and guidelines*

The IMAS series of standards has been recognised and endorsed by the international community. Mine dog detection is an element of this package, with five standards describing how to treat, test and use mine dogs. The MDD standards have been developed in collaboration with the UN, GICHD and various MDD organisations. It is difficult to write standards that satisfy all segments of an industry, but the MDD series of standards have largely been perceived as suitable. That said, results from systematic empirical field experience and research results suggest the need for a revision in the near future to accommodate the new “wisdom”. Revision of standards is a time-consuming and costly process and should be avoided if there is no real need or if there are few changes to the original conditions. However, the results from field-testing of the standards and from the studies reviewed in this book imply a comprehensive revision, likely to be initiated in 2003. As part of that process, it is essential that the standards are fully understood and that there is IMAS compliance within the MDD community. The MDD community itself has recognised these requirements and the GICHD has been asked to play a facilitating role and to manage a process of training and helping national mine action authorities and demining organisations. This work, identified as the Mine Dog Standards Implementation and Support Committee (SISC), began in 2002 and will be further intensified in 2003.

### **The way ahead: issues to debate**

Improving demining is more than just improving technology. Improvements depend on political issues, coordination of funds, collaboration between operators, regulatory authorities, donors, research institutions, the UN and more. It is difficult to predict the future of MDD because it depends on a changing political environment and international cooperation between actors. The GICHD is prepared to continue to work towards improvements of the MDD industry, in terms of improving the technology and by actively influencing the framework of the MDD industry. The table below reflects some of the many current trends and problems of MDD. Each topic is followed by a section which is meant to facilitate discussion about the future of MDD.

#### **Stand-by route clearance – funding/coordination**

About 750 dogs are currently used in 23 countries, but almost half of them are in only two countries (Afghanistan and Iraq). There are few mine detection dogs in other mine-affected countries. The overall impact on global demining is thus limited.

International humanitarian demining operations were previously undertaken in a few countries, but the trend is now to resolve landmine problems in many countries concurrently. This does not mean that more mines are laid today than before, but there is a growing international pressure to resolve the global landmine problem. This has caused a growing need for rapid route clearance and, in the absence of alternative technology, MDD is one of the few real alternatives. Yet some of the major commercial MDD companies have said that the market is too small to consider further expansion. At the same time, the UN complains about the lack of MDD capacity in many countries, especially those with an urgent route clearance requirement. The discrepancy between the UN and the MDD community in defining the requirement is a paradox. Clearly there is a need for more MDD, but it seems difficult to coordinate funds and requirements.



### Debate

If there is a need for a significant standby MDD capacity, it would perhaps help to examine why “free” MDD capacity is unavailable or is too expensive. One reason is market unpredictability, preventing investment into larger flexible MDD capacities. MDD may therefore maintain a less significant role in humanitarian demining if the framework of the industry remains the same as today. To change this would require initial investment from the international community in return for dog (or perhaps rat) teams that could be rapidly deployed around the world. Agreements could be made with one or several demining organisations and the dog/rat teams could be used in one or several permanent locations between emergency operations, including Angola, Bosnia and Herzegovina, Cambodia, Croatia, and Mozambique.

The key to success, if it is agreed that this is needed, is coordination of donors and funds. Donors need to work together in a depoliticised fashion on this issue, which is probably impossible without the help of the UN, the EU and some other major institutions.

### NGOs and MDD

NGOs have been careful in using dogs. When making choices between dogs and other technology (manual demining and to some extent mechanically assisted clearance systems), MDD loses because of too many opinions, uncertainties and unproven aspects of MDD.

### Debate

When basic principles of training, operational use and environmental effects are commonly understood, dogs and rats may become a real alternative for these organisations, again resulting in increased use of dogs and perhaps rats.

### Quality control and accident investigation

Missed mines are a greater problem than people like to talk about. Yet there is currently no reliable method to determine why dogs miss mines. The result is that MDD organisations always walk away free after investigation and this is an obstacle to improvement.

### Debate

Vapour detectors will eventually be produced, although they are likely to have several limitations compared to animals. Vapour technology could, however, prove useful when testing dogs and rats for quality control and accident investigation. If a missed mine has been found, soil, dust or air could be sampled and sent to centralised labs for analysis. This could be a simple process and the result could help determine whether there is detectable target scent above the mine.

### REST

REST has a major potential in humanitarian demining. Yet only two organisations use REST today and the technology consequently has a limited impact on global demining. REST is further limited to verification of roads. The lack of proven concepts of training and using REST dogs is probably the main obstacle to dissemination of the technology. Many organisations have shown interest in using REST, but are awaiting significant improvements of the REST concept and technology.

### Debate

With a few REST analysis facilities in central locations, there would be no need for demining operators to specialise in filter analysis. The far simpler sampling process could be undertaken by almost any demining organisation, thus making REST a better alternative than it is today. REST sampling teams may typically form part of emergency operations — for road clearance and area reduction. Filter cartridges could be sent out of the country for investigation. A small and adapted demining capacity can subsequently deal with positive (contaminated) sectors of land or road. All this requires that:

- REST has a proven potential for road verification and area reduction.
- There is sufficient REST analysis capacity to serve a greater market.
- Proven concepts of sampling have been developed and tested.
- The logistics, constraints and costs of shipping filters are affordable.

### Testing and accreditation

National test and accreditation regimes have only been established in a few countries. The mucky and time-consuming way of testing dogs prevent most countries from developing test and accreditation procedures. This again can be explored by MDD organisations, some of which are willing to trade poor quality of work in exchange for higher profit.

If only a few dogs are used in one country, it is questionable whether a test regime is worth establishing. Should dogs be used at all under these circumstances? Or should they be operational without any form of control and accreditation?

Current methods of testing dogs require vast areas, a high number of landmines and much preparation. It also takes about six months to plan, prepare and develop a test field (including the required soak time). This prevents testing and accreditation during early stages of demining operations — when dogs are typically most needed, when funds sit loose among donors and when there is no other quality control mechanism in place. The risk is that MDD organisations can get funds without being able to deliver a satisfactory product. Not being able to control the dogs and the clearance product means that any twist will always rule in favour of the MDD organisation. Under such circumstances, the risk of being “caught” for poor quality of work is small, especially when knowing that dogs are typically used in areas with a low density of landmines.

### Debate

The MDD industry will continue to improve further, resulting in a higher degree of self-regulation. The serious MDD organisations could find it beneficial to be accredited within a self-regulatory system. Donors are likely to be increasingly aware of potential problems with mine dogs/rats and funds could be withheld if an organisation has not received accreditation or has turned down membership of a self-regulatory system.

Testing of dogs could be easier and more technical with advancing technology and knowledge. Detection benchmarks could be established in the future and odours with different odour thresholds could be presented to the dogs for detection. If the dog is incapable of detecting target scent with a sufficiently low odour, it fails the test.

Future testing could involve a two-stage test, one aiming at showing ability to detect sufficiently low concentrations of target scent, and the other aiming at proving that the dog is sufficiently tuned in to the scent picture in the operational theatre. The first could be taken anywhere in the world and could be standard for all dogs. The second would be more area specific, perhaps for each country or area. It would be much easier for all mine action authorities to establish test regimes if there was no need to establish huge test facilities. Traditional ways of testing dogs could become redundant, provided that technology and proven methods of measuring concentrations and establishing reliable benchmarks have been developed.

### Dogs – primary or secondary clearance roles

The increased use of mechanical mine action systems has brought changes in the use of dogs. Mechanical mine clearance is rejected by many as being capable of full clearance. It is thus necessary to combine mechanical clearance with other clearance systems. Dogs have proved useful for verification behind machines and the combination with machines thus increases cost effectiveness. Machines play their greatest role in Europe, in countries like Bosnia and Croatia. One reason is that salary levels are much higher compared to developing countries in Asia and Africa. Manual demining is therefore less attractive as costs for manual operations are comparatively high.

#### Debate

It is interesting and surprising that dogs in some countries (Croatia and lately Bosnia and Herzegovina) are prevented by law from being used in a primary clearance role. The rationale for this rule is not known. It could, however, be a sign of low confidence in MDD. Another reason could be high unemployment and thus a desire to keep more people employed, typical for manual clearance methods. This is a real challenge and threat to the MDD industry. Clearly, dogs are useful in a follow-up role behind machines, but the use of dogs should not be so limited. That said, these legal restrictions emphasise the need for significant improvement of the MDD concept.

If governments distrust the reliability of dogs and this is why dogs have been prevented from primary clearance, systematic research coupled with operational improvement and documentation may help re-establish credibility.

### How to rely on environmental factors

It is commonly understood that vapour detection depends heavily on differences in soil properties and environmental effects. MDD organisations have a basic understanding of most of these effects but they are rated differently, resulting in a poorly defined potential for the use of dogs. It is thus likely that some landmines are missed because dogs are used under unfavourable conditions.

Although many weather factors are commonly understood, it is still difficult to relate their effects to availability of scent at ground level. The uncertainty is high as vapour at surface level heavily depends on leakage from the source itself — the landmine. We know that some landmines are less detectable than others, but knowledge is still limited in this field

#### Debate

Environmental factors and soil properties can be incorporated into computer modelling systems – in the future accessible via Internet, and usable in the field. An important but still missing element of the computer modelling system is the mine leakage library, an assessment of the vapour leakage of every known mine type. When we know the flux rate from landmines, we will have a pretty good means of predicting the level of target scent at surface level.

Organisations using rats, dogs or vapour detectors could use this facility to determine anticipated minimum level of scent, which again is to be compared with the odour threshold accreditation level for each dog, rat and vapour detector. The facility could also be used to measure predicted scent levels against proven detection levels for vapour detectors. Detection levels for dogs, rats and vapour detectors could be graphically represented against predicted scent levels in an area and this would help determine whether there is potential for the use of dogs, rats or vapour detectors.

# Glossary of terms

|           |  |
|-----------|--|
| ACU       | Applied Chemistry Unit   |
| ADSM      | Apparatus for Discrimination of Source Material                              |
| BAM       | Behaviour Assessment Model   |
| BCM       | Buried Chemical Model  |
| CR        | conditioned response   |
| CRS       | continuous reward schedule   |
| CS        | conditioned stimulus   |
| CSIR      | Commonwealth Scientific and Industrial Research (South Africa)               |
| DGIS      | Belgian Directorate for International Cooperation                            |
| EBS       | electric brain stimulation   |
| EVD       | Explosive Vapour Detection   |
| DNB       | dinitrobenzene   |
| DNT       | dinitrotoluene   |
| FDTA      | Fjellanger Dog Training Academy AS   |
| FIRS      | fixed interval reward schedule   |
| FOI       | Swedish Defence Research Agency  |
| FRRS      | fixed ratio reward schedule  |
| GTA       | Global Training Academy  |
| GICHD     | Geneva International Centre for Humanitarian Demining                        |
| GPS       | Global Positioning System  |
| HD        | Humanity Dog   |
| IBDS      | Institute for Biological Detection Systems, Auburn University, Alabama, U.S. |
| IMAS      | International Standards for Mine Action                                      |
| JND       | just noticeable difference   |
| MAC       | Mine Action Centre   |
| MDD       | mine detection dog   |
| MEDDS     | Mechem Explosives and Drug Detection System                                  |
| MEDDS/EVD | MEDDS sub-study IV - Vapour Sampling and Analysis                            |
| NOKSH SA  | Norsk Kompetansesenter for Spesialsøkshund AS                                |
| NPA       | Norwegian People's Aid   |
| PDMS      | Poly DiMethyl Siloxane   |

|           |   |
|-----------|---|
| PVC       | polyvinyl chloride  |
| R&D       | research and development  |
| RDX       | A kind of high explosive, chemically 1,3,5-trinitrohexahydro-1,3,5-triazine, $(N(NO_2)CH_2)_3$ . Also called hexogen. |
| REST      | Remote Explosives Scent Tracing   |
| RUCA      | Department of Biology, University of Antwerp  |
| SOP       | Standing Operating Procedure  |
| SPME      | Solid Phase Micro Extraction  |
| SPMR-GCMS | Gas Chromatography/Mass Spectrometry  |
| SUA       | Sokoine University of Agriculture   |
| TNT       | Trinitrotoluene   |
| TPDF      | Tanzanian People's Defence Forces   |
| TRI       | Texas Research Institute  |
| SPME      | Solid Phase Micro Extraction  |
| UN        | United Nations  |
| UR        | unconditioned response  |
| US        | unconditioned stimulus  |
| UXO       | unexploded ordnance   |
| VIRS      | variable interval reward schedule   |
| VRRS      | variable ratio reward schedule  |

## Notes on contributors

**Håvard Bach** has broad experience running and working with mine action programmes. He is Head of Operational Methods at the GICHD in Geneva.  
*h.bach@gichd.ch*

**Mic Billet** is part-time Professor of Communication Sciences at the University of Antwerp, and Chairman of APOPO.  
*apopo@zeus.ruca.ua.ac.be*

**Christophe Cox** and **Bart Weetjens** are Research Managers for APOPO at the Sokoine University of Agriculture, Morogoro, Tanzania.  
*apopo@zeus.ruca.ua.ac.be*

**Ambassador Martin Dahinden** is a career diplomat with the Swiss Foreign Ministry. He has been the Director of the Geneva International Centre for Humanitarian Demining since May 2000. Before assuming the directorship of the GICHD he was Deputy Head of the Swiss Mission to NATO in Brussels.  
*m.dahinden@gichd.ch*

**Rune Fjellanger** originally trained as a biologist, and trained dogs for explosives and mine detection in the Norwegian military. He has co-written several books on dog training and human-dog relationships. He is now Head of Practise at Fjellanger Dog Training Academy in Os, Norway, and a director of Norsk Kompetansesenter For Spesialsøkshund AS (NOKSH AS).  
*rf@noksh.com*

**Ann Göth** trained in animal behaviour, and worked for the GICHD on the behaviour of mine detection dogs during 2001. She is now a post-doctoral fellow in the Department of Psychology at Macquarie University, Sydney.  
*ann@galliform.psy.mq.edu.au*

**Dan Hayter** retired from the U.S. Air Force in 1985 after two decades of extensive experience as a dog operator, trainer and instructor, using dogs for security and patrol services and for detection of explosives and narcotics. He co-founded Global



Training Academy at Somerset, Texas, in 1984. The Academy began doing humanitarian mine detection using dogs in 1989. To date it has produced some 400 mine detection dogs and helped to develop national capacities in 15 mine-affected countries.

*GTADAN@aol.com*

**Stewart Hilliard** originally trained competitive working dogs and police service dogs, and has taught and written extensively on dog training issues. He is now Associate in Military Working Dog Studies with the Department of Defense Military Working Dog Veterinary Service at Lackland Air Force Base, Texas.

*STEWART.HILLIARD@LACKLAND.AF.MIL*

**Vernon Joynt** headed many demining programmes and initiatives during his tenure as Director of Mechem, South Africa. Originally trained as a chemist, he recently retired from Mechem and now works for the South African CSIR as a consultant.

*vjoynt@csir.co.za*

**André Le Roux** started his dog career in the South African Defence Force in 1991. From 1992 to early 1998 he was an operational dog handler with Mechem, working with REST dogs. He co-founded the South African Mine Dog Centre in 1998, and since then has successfully deployed operational mine detection dog teams globally.

*mdcentre@mweb.co.za*

**Robert Machangu** is Professor and Head of the Pest Management Centre at Sokoine University of Agriculture, Morogoro, Tanzania.

*apopo@zeus.ruca.ua.ac.be*

**Per Jostein Matre** is a clinical psychologist and supervisor in child and family welfare matters, and has undertaken extensive work in applied animal psychology including co-writing several books on dog training and human-dog relationships. He is currently Head of Evaluation Projects at Norsk Kompetansesenter For Spesialsøkshund AS (NOKSH AS).

*pjm@noksh.com*

**Ian G. McLean** is a biologist and animal psychologist who works as a researcher and operations analyst at the GICHD.

*i.mclean@gichd.ch*

**James M. Phelan** and **Stephen W. Webb** are employed at the Environmental Technology Department of Sandia National Laboratories, Albuquerque, New Mexico. Sandia is a multiprogramme laboratory operated by Sandia Corporation, a Lockheed Martin company, for the United States Department of Energy.

*jmpphela@sandia.gov, swwebb@sandia.gov*

**James Trevelyan** is Associate Professor of Mechanical Engineering at the University of Western Australia, Perth. He has worked on many aspects of mine clearance since 1996 and conducts research in Australia and Pakistan.

*James.Trevelyan@uwa.edu.au*

**Johan Van Wyk** started his dog career in the South African Defence Force in 1989. From 1992 to 1998 he ran a dog training school and also worked for Mechem as a

---

mine detection dog handler in Croatia. He co-founded the South African Mine Dog Centre in 1998, and since then has successfully deployed operational mine detection dog teams globally.

*mdcentre@mweb.co.za*

**Ron Verhagen** is Professor of Biology and Chairman of the Department of Biology at the University of Antwerp in Belgium. He is involved part-time as a scientist in APOPO.

*apopo@zeus.ruca.ua.ac.be*





Geneva International Centre for  
Humanitarian Demining  
Centre International de  
Démunage Humanitaire - Genève

Geneva International Centre for Humanitarian Demining  
7bis, avenue de la Paix  
P.O. Box 1300  
CH - 1211 Geneva 1  
Switzerland  
Tel. (41 22) 906 16 60, Fax (41 22) 906 16 90  
[www.gichd.ch](http://www.gichd.ch)